

NEW WATER VALVES FOR SCANIA VEHICLES

In response to the needs of our customers of the Independent Aftermarket (IAM), we have launched three types of water valves for Scania vehicles. The water valves are designed for climate control systems (Automatic Temperature Control - ATC) in bus applications.

Check our offer, keep your parts genuine and expand your business with WABCO. The water valves are available now.

BENEFITS

- 100% compatible with Scania OE variants
- Original replacement parts with a perfect fit and OE performance
- Robust and reliable design helps to reduce vehicle downtime and maintenance costs
- Resistant against vibration, overpressure and pressure pulses
- Resistant against corrosion

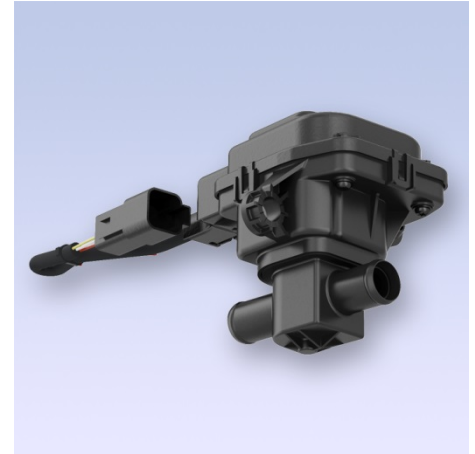

Water valve 446 091 030 0

PRODUCT DESCRIPTION

The motor-driven water valve in conjunction with an Electronic Control Unit automatically regulates the temperature by controlling the coolant rate of flow through the heat exchanger. The valve is driven by a geared DC motor unit. A potentiometer gives a position feedback of the valve. The manually operated water valve is operated via a bowden cable.

PRODUCT NUMBERS, CROSS REFERENCES AND PRICES

WABCO product number		Gross price			Cross reference Scania
IAM	OE	EUR	GBP	CHF	
446 091 030 0	446 091 010 0	280.00	234.00	348.00	2160199
446 091 031 0	446 091 503 0	116.00	96.70	144.00	1450166 / 1795464
446 091 032 0	446 091 505 0	116.00	96.70	144.00	1789068 / 1868457

Information on WABCO products can be found in our [webshop](http://webshop.wabco-auto.com) (webshop.wabco-auto.com) by entering the product number in the "Search Products" field.

Please contact your [WABCO partner](http://www.wabco-auto.com/findwabco) for further information (www.wabco-auto.com/findwabco).