

1

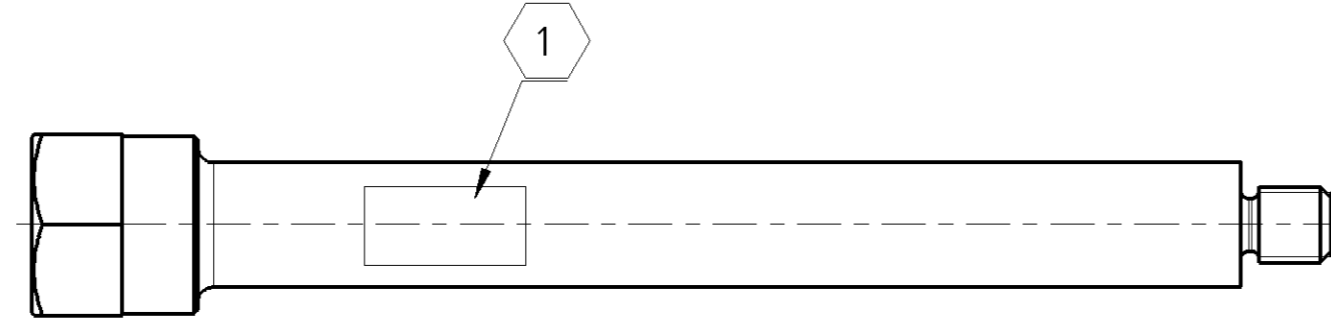

2

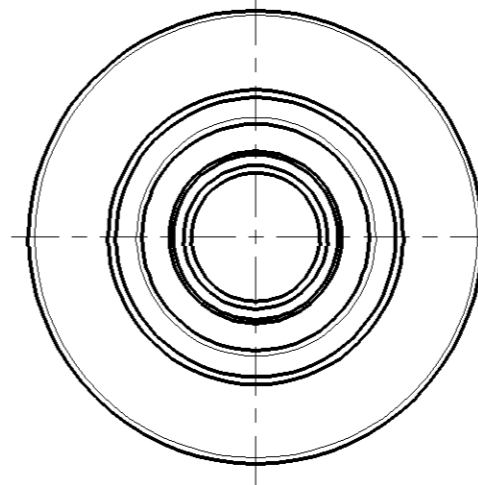
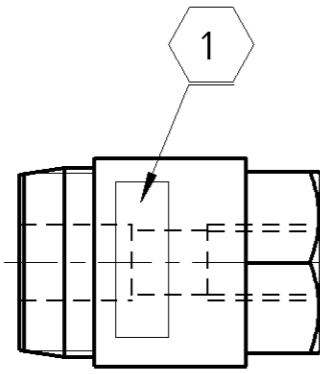

3

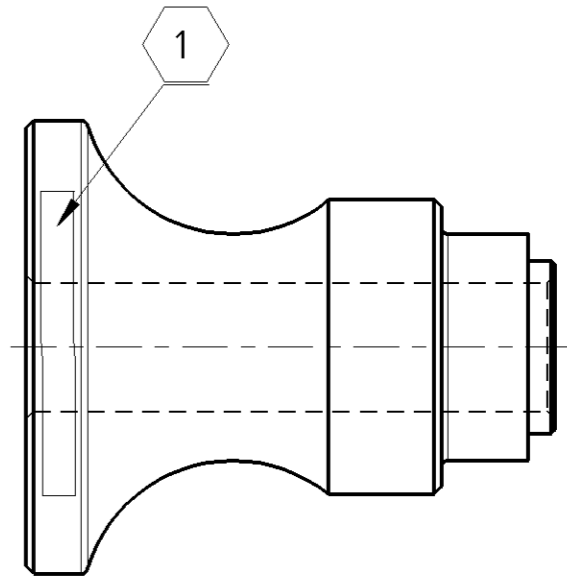

1 Part number / Date code / WABCO logo  
Teilenummer / Datum / WABCO Schriftzug

General Specification: JED-334-1, Size ISO 14405 LP		Copyright WABCO®		<b>WABCO</b>		
Further Technical Data:		Date	Signature			
Doc. Code:	Sheet:	To:	2016-06-22	Skoczylas		
General Tolerances JED-261			2016-06-22	Przybysz		
Range of Nominal Dimensions ( ± mm)			Expert			
Class	1)	≤ 50	> 50 ≤ 180	> 180 ≤ 400	> 400	±3°
Fine		0.5	1.0	1.5	2.0	Stumpf
Medium	X	1.0	2.0	3.0	4.0	
Coarse		2.0	3.5	5.0	6.5	
Tapped Holes acc. -			Mass	Scale	Material No.	Date of first issue: 2016-06-22
1) Tolerance Class Applied Crossmarked			kg	1:2	300 100 011 2	Doc.Code Language Sheet
			Size	CAD System	005 ML 1/1	
			A 2	CREO	ECN-No.	Revision Techn. Resp.
					-	- 0963
			Replacement for			

Non e' permesso copiare, o terzi o riprodurre questo documento, ne utilizzare il contenuto o renderlo comunque noto a terzi senza autorizzazione esplicita. Ogni infrazione costituisce un evidente abuso e comportera il risarcimento dei danni subiti. E' fatta riserva di tutti i diritti derivanti da brevetti o modelli.

Tout droit de reproduction de ce document, toute exploitation ou communication de son contenu sont interdites, sauf autorisation expresse. Tout manquement a cette regle constitue un abus evident et expose son auteur au versement de dommages et interets. Tous droits de proprieete industrielle reserves, notamment en matiere de brevets et de modeles.

Copying of this document and giving it to others and the use or communication of the contents thereof, are forbidden without express authority. Contravention of this restriction will constitute an evident abuse and result in a liability to the payment of damages. All rights are reserved in the event of the grant of patent or registration of a utility model or design. This document is the subject of copyright.

Wskazane prawa wykorzystania tego dokumentu, jego rozpowszechnienie i komunikacja jego treścią, bez zgody WABCO, są zabronione. Wszelkie naruszenia tych praw skutkują odpowiedzialnością prawną. Wszelkie prawa zastrzeżone. Wszelkie prawa do patentów i znaków towarowych są zarezerwowane. Wszelkie prawa do patentów i znaków towarowych są zarezerwowane. Wszelkie prawa do patentów i znaków towarowych są zarezerwowane.

Set	Part description	Teil Bezeichnung	WABCO Part Number
1	Grip	Griff	300 100 011 4
2	Extracting tool	Abzieher	300 100 018 4
3	Striker	Schlag-Bolzen	300 100 004 4