

SURFACE PROTECTION
OBERFLAECHENSCHUTZ
PROTECTION DE SURFACE
PROTEZIONE SUPERFICIA

I : JED-649-0
 II : JED-256-0
 III : JED-471-0

WABCO

Letzter Wechsel / date of change

Jahr/Year	15	16	17	18	19	20	21	22	23	24	25	26
Monat/Month	01	02	03	04	05	06	07	08	09	10	11	12

432 911 228 2
 G 1 1/4"
 max. 14 bar

Made in Germany

Return to WABCO

WABCO

WABCO

Air System Protector PLUS

3 Years System Protection*

Instructions

DE: 1. Achtung: Vor Ausbau Lufttrockner entlüften, 2. Dichtung und Gewindezapfen vor Montage einfetten, 3. Behälter von Hand fest aufschrauben (max. 15 Nm), *3 Jahre Lebensdauer unter Normalbedingungen

EN: 1. Important: Ventilate air dryer before removing, 2. Grease seal and threaded spigot before installation, 3. Screw the container on firmly by hand (max. 15 Nm), *3 year service life under normal conditions

FR: 1. Attention: purger le dessiccateur avant le démontage, 2. Graisser le joint et le filetage avant montage, 3. Visser fermement la cartouche à la main (15 Nm max.), *Durée de vie: 3 ans dans les conditions normales d'utilisation

ES: 1. Atención: Purgar el secador antes de realizar el desmontaje, 2. Engrasar junta y vástagos roscados antes de proceder a su instalación, 3. Roscar firmemente el cartucho a mano (max. 15 Nm), *3 años de duración bajo condiciones normales de servicio

PT: 1. Importante: Antes da desmontagem eliminar o ar comprimido do secador de ar, 2. Engraxar a superfície de vedação e a rosca de fixação, 3. Parafusar manualmente a nova peça (torque max. 15Nm), *3 anos de vida útil em condições normais

РУС: 1. Важно: Перед заменой удалите грязь с корпуса осушителя воздуха, 2. Смажьте резьбу перед сборкой, 3. Усилим руки (Не более 15 Нм) закрутите корпус картриджа осушителя воздуха, *Замена 1 раз в 3 года при обычных условиях эксплуатации

LABELLING
 BESCHRIFTUNG
 ETIQUETAGE
 ETICHETTATURA

DATE OF MANUFACTURE
 HERSTELLDATUM (YYMM)
 DATE DE FABRICATION
 DATA DI FABBRICAZIONE

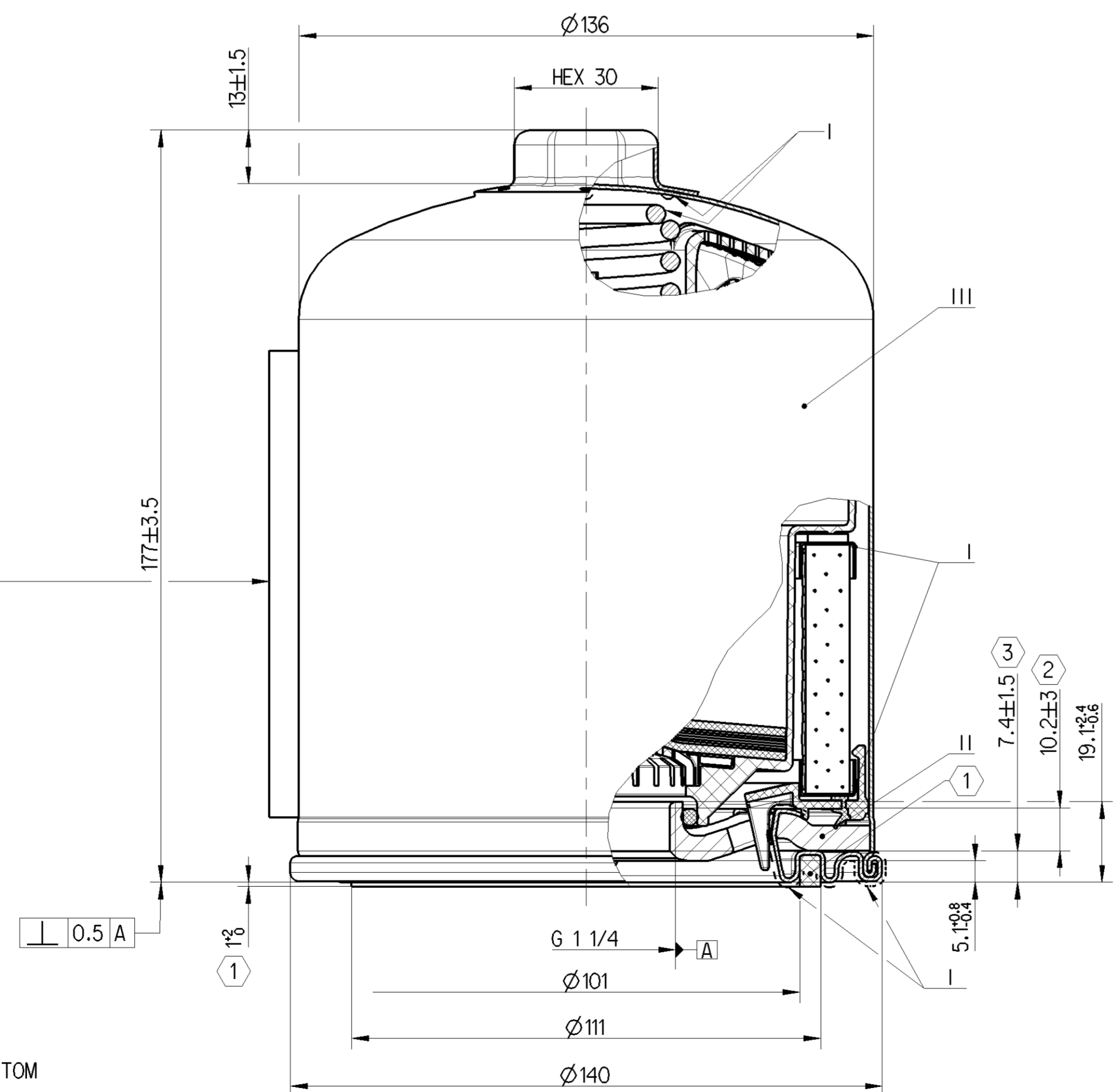

- ① DIMENSION APPLY IF THE SEAL IS IN CONTACT WITH THE GROOVE BOTTOM
 MASSE GELTEN BEI ANLEGENDER DICHTUNG AM NUTGRUND
- ② MEASURED FROM TOP TO BOTTOM FULL THREAD TURN BY CONTOUR GRAPH
 GEMESSEN VOM OBEREN BIS UNTEREN VOLLEN GEWINDEGANG MIT KONTURGRAPH
- ③ MEASURED FROM BOTTOM FULL THREAD TURN TO FIRST RING RADIUS BY CONTOUR GRAPH
 GEMESSEN VOM UNTEREN VOLLEN GEWINDEGANG BIS ERSTEN RINGRADIUS MIT KONTURGRAPH

THERMAL RANGE OF APPLICATION:
 THERMISCHER ANWENDUNGSBEREICH: -40°C ... +80°C
 GAMME D'APPLICATION THERMIQUE:
 CAMPO DI APPLICAZIONE TERMICA:

WORKING PRESSURE:
 BETRIEBSDRUCK: P_gmax. = 14 bar
 PRESSION DE SERVICE:
 PRESSIONE D' ESERCIZIO:

① SEALING RING (OUTSIDE):
 DICHTRING (AUSSEN): NBR 70±5 SHORE A
 JOINT D'ETANCHEITE (EXTERIEUR):
 ANELLO DI TENUTA (ESTERNO):

O-RING:
 O-RING : NBR 65±5 SHORE A
 JOINT TORQUE
 O-RING:

PERMISSIBLE LEAKAGE: MAX. 6 cm³/min AT 10 bar TEST PRESSURE
 ZULAESSIGE LECKAGE: MAX. 6 cm³/min BEI 10 bar PRUEFDRUCK
 FUITE AMISE: MAX. 6 cm³/MIN A 10 bar PRESSION D'ESSAI
 FUGA AMMESSA: MAX. 6 cm³/MIN AL 10 bar PRESSIONE DI PROVA

TEXT: BLUE
 TEXT: PANTONE 293 BLAU
 TEXTE: BLEU
 TESTO: BLU

BACKGROUND COLOR:
 UNTERGRUND: RAL 1036 PEARL GOLD
 COULEUR DU FOND: OR NACRE PERLGOLD
 COLORE DEL FONDO: ORO PERLATO

General Specification: JED-334-1 - Size ISO 14405 LP		Copyright WABCO®	
Further Technical Data: Product Specification		Date: 2016-03-30	Signature: [Blank]
Doc. Code: O35	Sheet: 1 To 3	Drawn: Marek	Checked: Pendzich
General Tolerances JED-261		Expert: Friedrich M.	
Range of Nominal Dimensions (± mm)			
Class	11	≤ 50	> 50 > 180 > 400
Fine	X	0.5	1.0 1.5 2.0
Medium		1.0	2.0 3.0 4.0
Coarse		2.0	3.5 5.0 6.5
Tapped Holes acc. 1) Tolerance Class Applied Crossmarked			
Mass: 2.3 kg		Scale: 1:1	
Size: A 1		CAD System: CREO	
Material No.: 432 911 228 2		Date of first issue: 2016-04-01	
Doc. Code: 005		Language: ML	
Revision: -		Techn. Resp.: 5059	
Replacement for:			

Note: Permission to reproduce this document, in whole or in part, is granted, provided the copyright notice is included in the reproduction. No part of this document may be reproduced, stored in a retrieval system, or transmitted, in any form or by any means, electronic, mechanical, photocopying, recording, or by any information storage and retrieval system, without the prior written permission of WABCO.