

SURFACE PROTECT.
OBERFL. SCHUTZ

I	JED-260
II	JED-256-1 (H)

IDENTIFICATION ACCORDING TO:
KENNZEICHNUNG NACH: JED-341
IDENTIFICATION SUIVANT:
INDICAZIONE SECONDO:

WORKING PRESSURE:
BETRIEBSDRUCK: $P_e = \text{MAX. } 13 \text{ bar}$
PRESSION DE SERVICE:
PRESSIONE D'ESERCIZIO:

CHARGING PRESSURE:
UEBERSTROEMDRUCK: $P_e = 0.5_{-0.3}^0 \text{ bar } (P_2 = 0 \text{ bar})$
PRESSION DE BARRAGE:
PRESSIONE DI PRESA:

THERMAL RANGE OF APPLICATION:
TERMISCHER ANWENDUNGSBEREICH: $-40^\circ\text{C.} \dots +80^\circ\text{C}$
GAMME D'APPLICATION THERMIQUE:
CAMPO DI APPLICAZIONE TERMICA:

MEDIUM: AIR
MEDIUM: LUFT
FLUIDE: AIR
FLUIDO: ARIA

NOMINAL DIAMETER:
NENNWEITE: $\varnothing 8 \text{ mm} = 50 \text{ mm}^2$
DIAMETRE NOMINAL:
DIAMETRO NOMINALE:

WITH RETURN FLOW
MIT RUECKSTROEMUNG
AVEC RETOUR
CON RITORNO

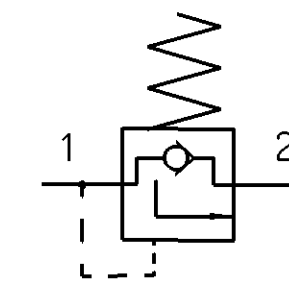

SUPPLY
1 ENERGIEZUFLOSS
ALIMENTATION
ALIMENTAZIONE

DELIVERY
2 ENERGIEABFLUSS
UTILISATION
MANDATA

TORQUE FOR CONNECTIONS:
ANZUGSMOMENT FUER EINSCHRAUBSTUTZEN: $M22x1.5: M_{\text{max.}} = 53 \text{ Nm}$
COUPLE DE SERRAGE DES RACCORDS:
COPPIA DI SARRAGGIO DEI RACCORDI:

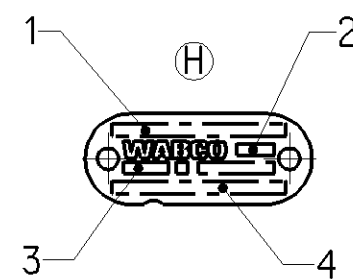
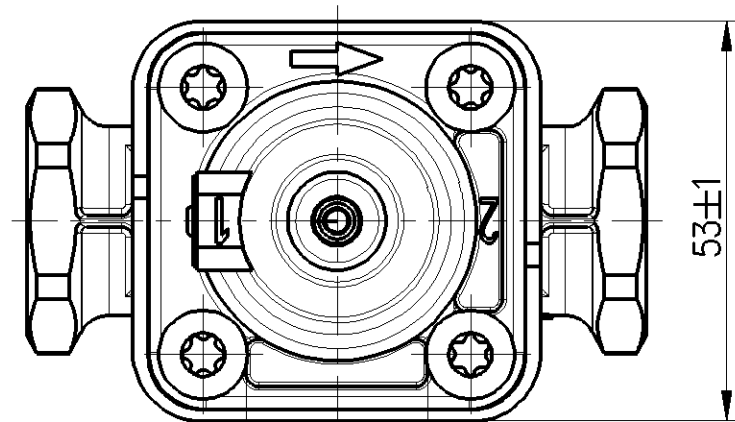
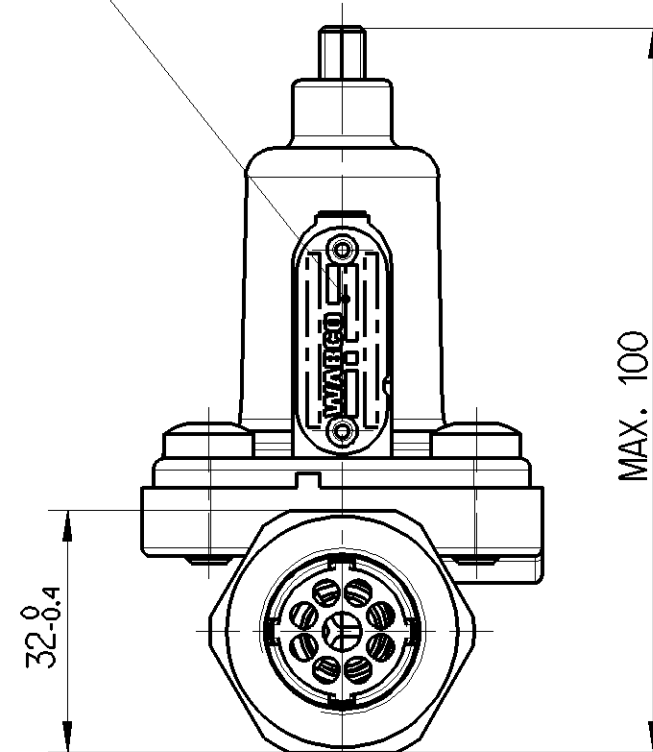
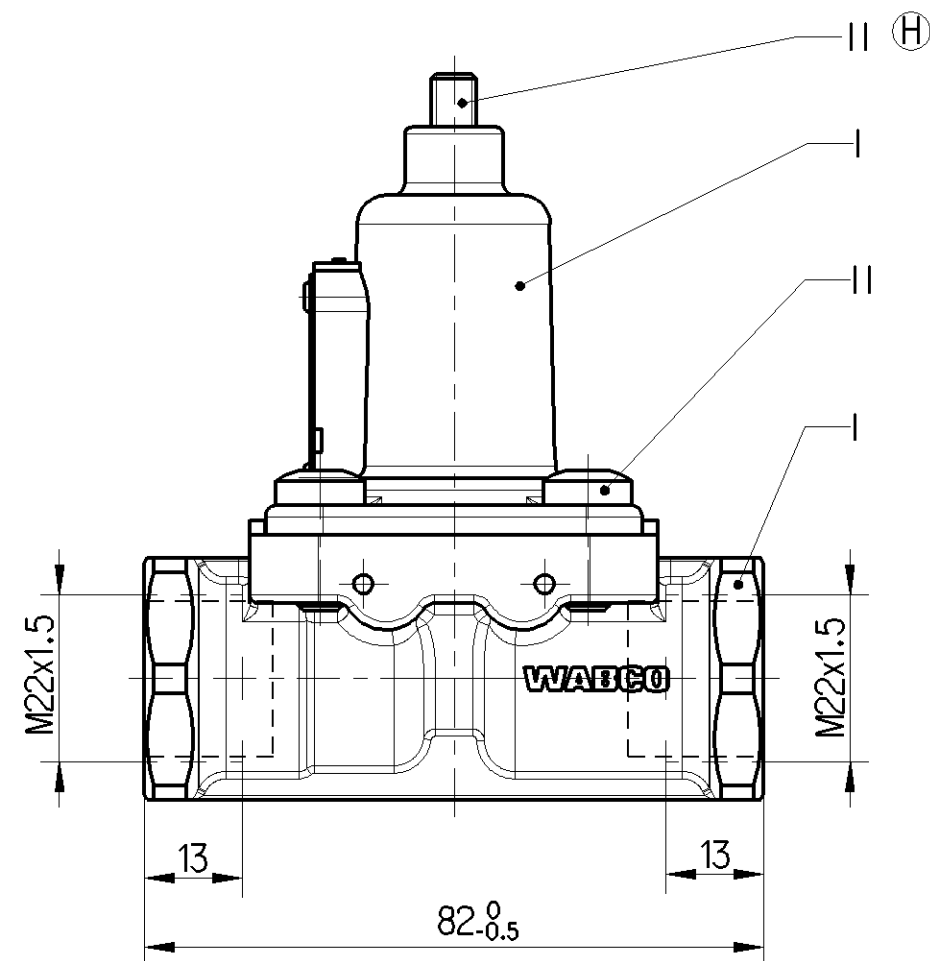

(H)
1 CUSTOMER NO. OR COUNTRY OF ORIGIN
KUNDEN-NR. KZ ODER WARENURSPRUNGSLAND
2 MANUFACTURING PLANT
PRODUKTIONSSTAETTE JED-225

3 WEEK / YEAR OF MANUFACTURE
FERTIGUNGSWOCHE / -JAHR
4 WABCO-DEVICE NUMBER
WABCO-GERAETE NUMMER

General Specification: JED-334-1 Size ISO 14405 LP		Copyright WABCO®		WABCO		
Further Technical Data:		Date	Signature	2015-07-16 Cwirkalski		
Doc. Code: Sheet: To		2015-07-20	Checked	2009-08-12		
General Tolerances JED-261		Expert		005 ML 1/1		
Class 1) Range of Nominal Dimensions (± mm)		Gontarz		434 100 027 0		
Fine	≤ 50 > 50 ≤ 180 > 180 > 400	Mass	Scale	Material No.		Date of first issue: 2009-08-12
Medium	1.0 2.0 3.0 4.0	(H) 0.412 KG	1:1	ECN-No.		Doc.Code Language Sheet
Coarse	2.0 3.5 5.0 6.5	Size	CAD System	Revision		005 ML 1/1
Tapped Holes acc.		A 2	CREO	Techn. Resp.		5 x H 5120
1) Tolerance Class Applied Crossmarked				Replacement for		

100mm

Non è permesso copiare o terzi o riprodurre questo documento, né utilizzare il contenuto o renderlo comunque noto a terzi senza permesso scritto dalla WABCO. È vietata espressamente la ristampa o l'uso non autorizzato in qualsiasi forma e con qualsiasi mezzo. E' fatto riserva di tutti i diritti, espressi o non, di brevetto o di marchio. Copying of this document and giving it to others and the use or communication of the contents thereof, are forbidden without express written permission from WABCO. It is expressly prohibited to reproduce or use the content of this document in any form and by any means without the express written permission of WABCO. All rights reserved in the event of the grant of patent or registration of a utility model or design. This document is the subject of copyright.

Toute communication ou reproduction de ce document, toute exploitation ou communication de son contenu sont interdites, sauf autorisation expresse. Tout manquement à cette règle constitue un abus évident et expose son auteur au versement de dommages et intérêts. Toute réimpression ou utilisation non autorisée sans la permission écrite de la WABCO est formellement interdite. Toute réimpression ou utilisation non autorisée sans la permission écrite de la WABCO est formellement interdite. Weitergabe sowie Vervielfältigung dieses Urteils, Verwertung und Mitteilung ihres Inhalts nicht gestattet, soweit nicht ausdrücklich zugelassen. Zuwiderhandlungen stellen einen strafrechtlichen Missbrauch dar und verpflichten zu Schadensersatz. Alle Rechte für den Fall der Patentierung oder Gebrauchsmuster-Eintragung vorbehalten.