

A	ZINC COATED STEEL	JED-585-2
B	ABS	JED-465-5
C	PBT GF20	JED-375-1
D	TIN-PLATED COPPER	JED-570-545
E	POLYESTER	

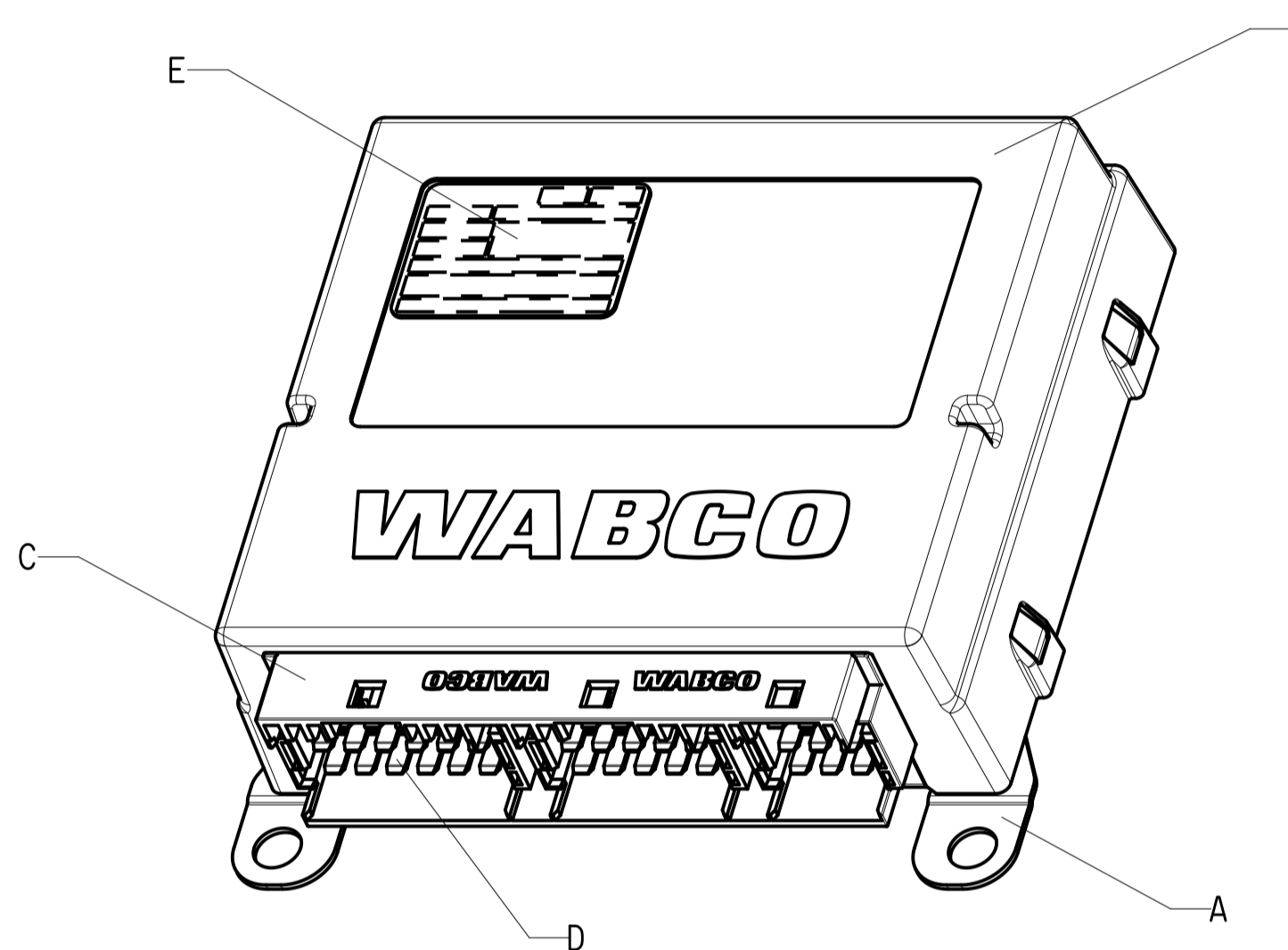
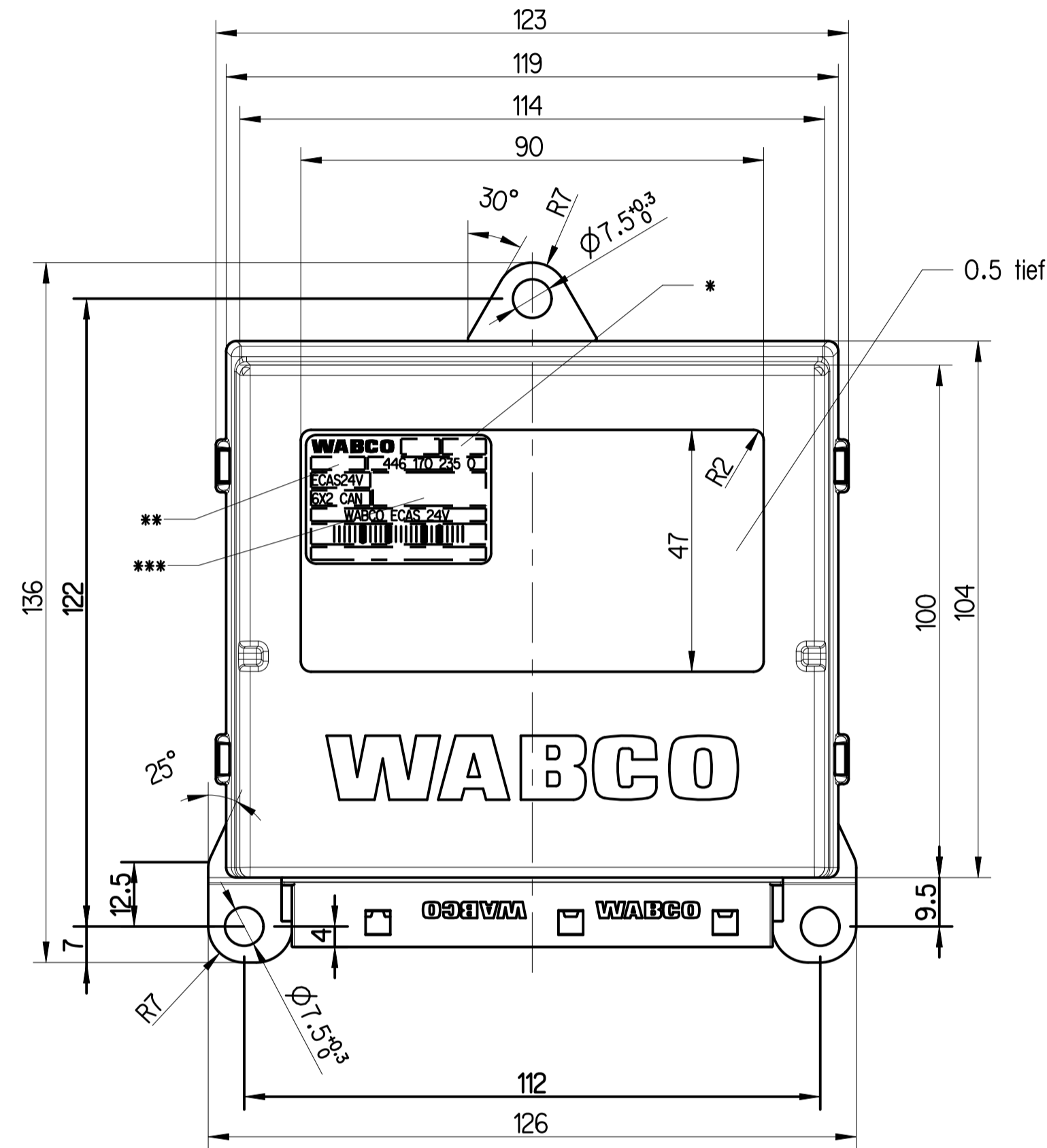
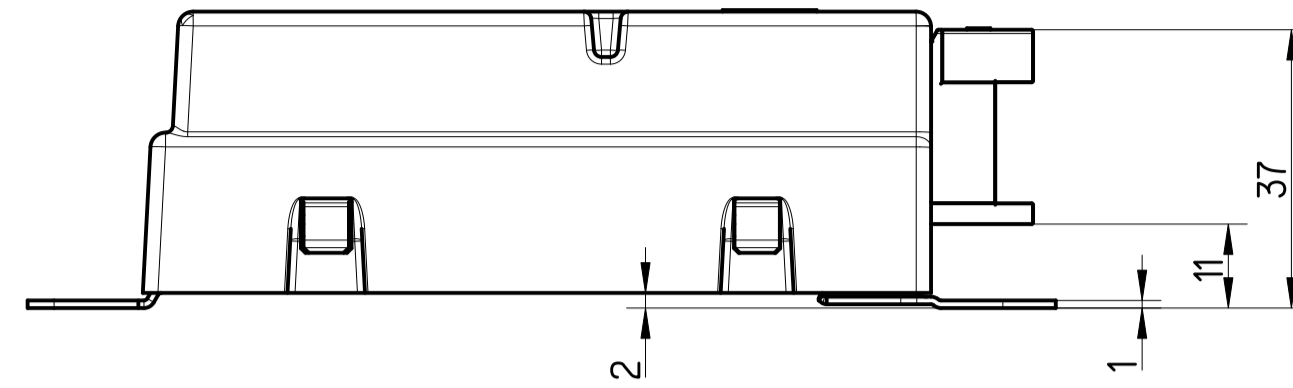
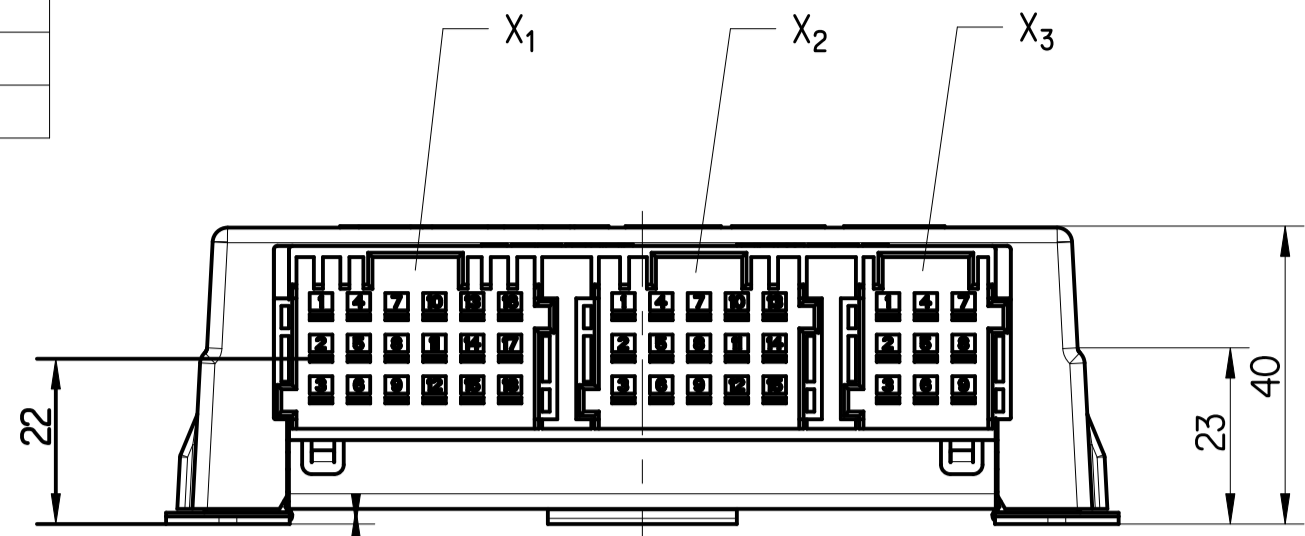

DATE OF MANUFACTURE:
 * HERSTELLDATUM: JED-226
 DATE DE FABRICATION:
 DATA DI FABBRICAZIONE:

SERIAL NUMBER GREATER THAN:
 ** FORTSCHRITZAHN GROESSER ALS: 0
 NUMERO DE SERIE PLUS GRAND QUE:
 NUMERO DI SERIE PIU GRANDE DI:

INSPECTION MARK:
 *** PRUEFZEICHEN: (E1) 10R-062063 (A)
 MARQUE DE CONTROLE:
 STAMPA DI COLLAUDO:

VOLTAGE:
 SPANNUNG: 22 V ... 32 V DC
 TENSION:
 TENSIONE:

THERMAL RANGE OF APPLICATION:
 THERMISCHER ANWENDUNGSBEREICH: -40 °C ... +75 °C
 GAMME D'APPLICATION THERMIQUE:
 CAMPO TERMICO D'APPLICAZIONE:

STORAGE TEMPERATURE:
 LAGERTEMPORATUR: -40 °C ... +90 °C
 TEMPERATURE DE STOCKAGE:
 TEMPERATURA DI IMMAGAZZINAMENTO:

DEGREE OF PROTECTION:
 SCHUTZART: IP 30 (IEC 529)
 DEGRE DE PROTECTION:
 GRADO DI PROTEZIONE:

FURTHER TECHNICAL DATA SEE PRODUCT SPECIFICATION:
 WEITERE TECHNISCHE DATEN SIEHE PRODUKTSPEZIFIKATION (INDEX BEACHTEN): 446 170 235 0 (DOC. CODE 035)
 POUR AUTRES DONNEES TECHNIQUES VOIR SPECIFICATION DU PRODUIT:
 PER ULTERIORI DATI TECNICI VEDERE SPECIFICA DI PRODOTTO:

FINISHING VARNISH ON THE PRINTED BOARD:
 UEBERZUGSLACK AUF DER LEITERPLATTE: JED-543
 VERNIS ENDUIT SUR CARTE IMPRIMEE:
 VERNICE DI RIVESTIMENTO SULLA PIASTRA STAMPTA:

INSTALLATION POSITION:
 EINBAULAGE:
 POSITION D'INSTALLATION:
 POSIZIONE DI MONTAGGIO:

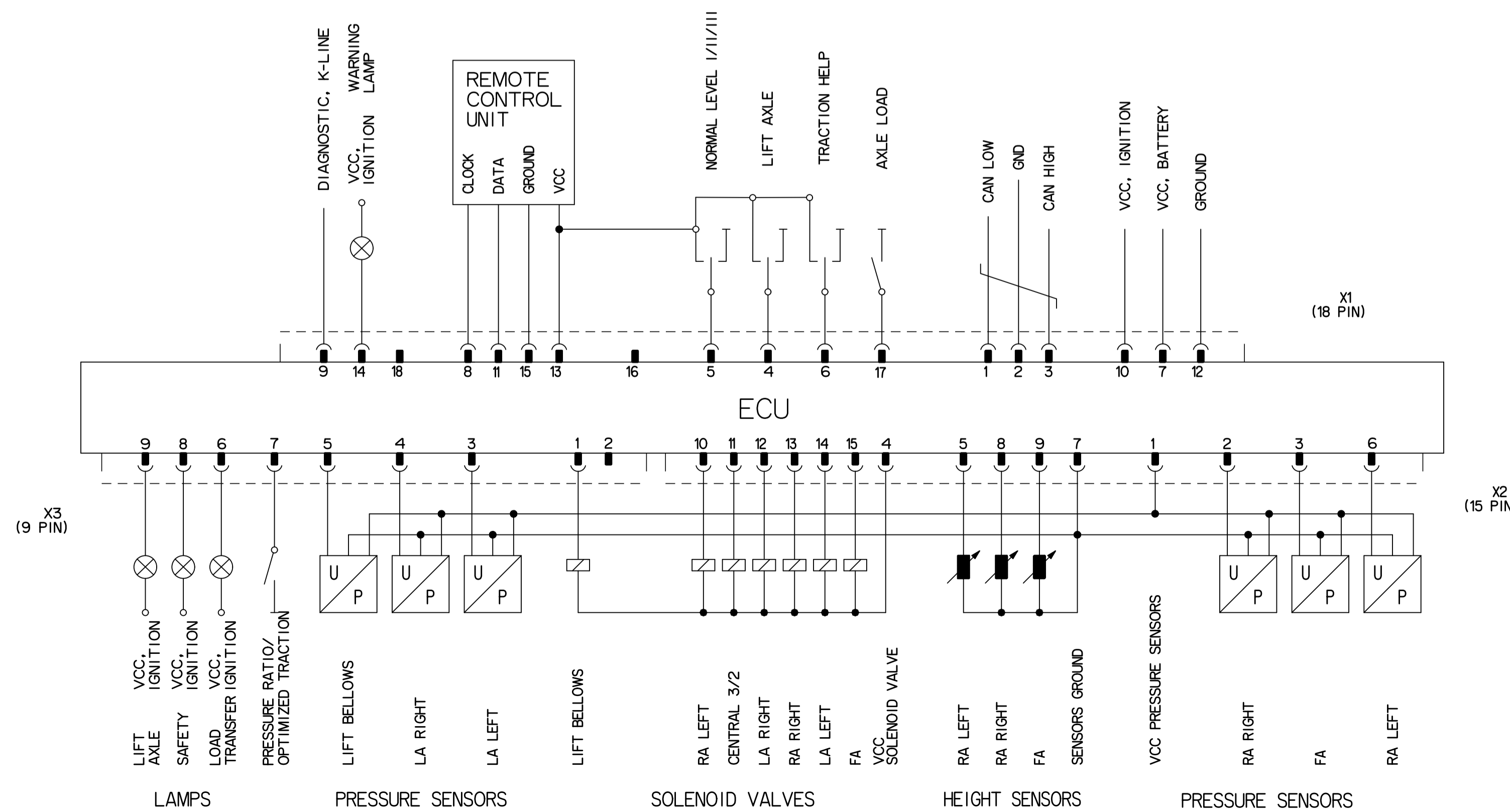
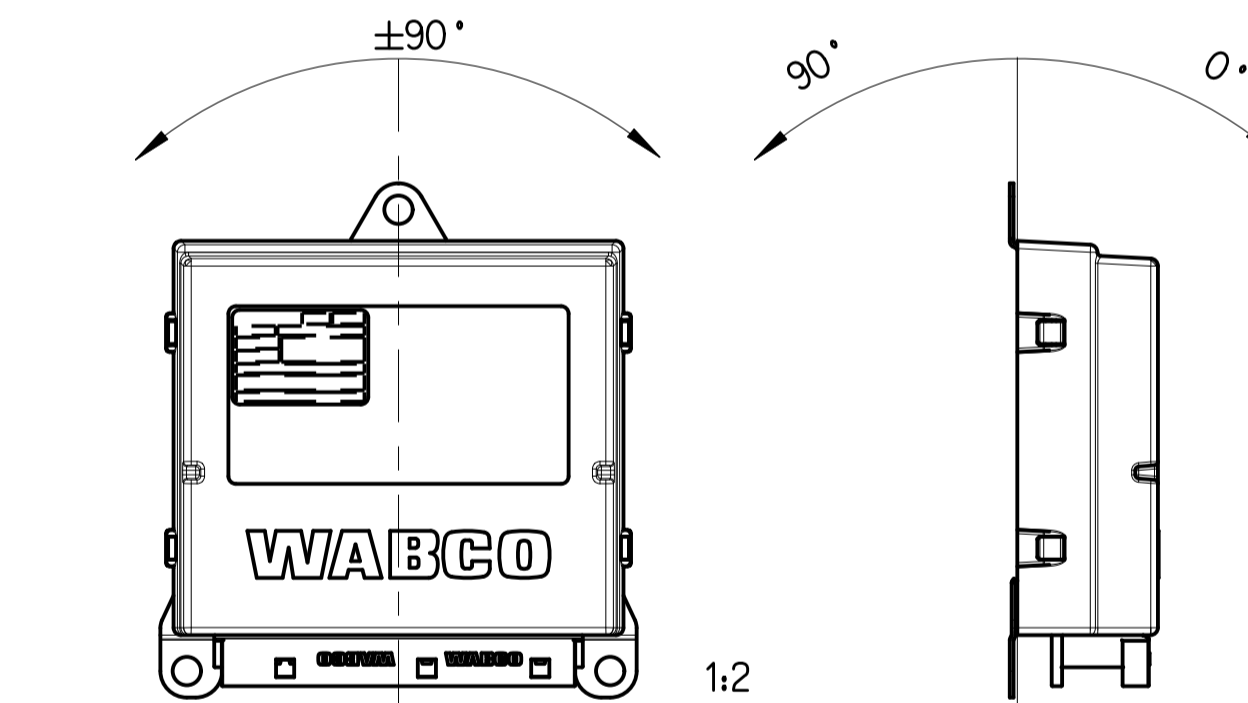

General Specifications: JED-334-1 - Size ISO 14405 LP		Copyright WABCO®	
Further Technical Data:		Date	Signature
Doc. Code:	Sheet: To	2025-09-17	Heyda
General Tolerances JED-261		Checked	Lucas
Range of Nominal Dimensions (± mm)		Expert	
Class	1) ≤ 50 > 50 > 180 > 400 > 400	Jovers	
Fine	0.5 1.0 1.5 2.0	Mass	Scale
Medium	1.0 2.0 3.0 4.0	0.280	1:1 (1:2)
Coarse	2.0 3.5 5.0 6.5	Size	CAD System
Tapped Holes acc.		Material No.	
1) Tolerance Class Applied Crossmarked		446 170 235 0	
		ECN-No.	Revision
		517727	ix A
		Techn. Resp.	6650
		Date of first issue: 2018-02-06	
		Doc. Code	Language
		005	ML
		Sheet 1/1	

Non è permesso copiare o riprodurre questo documento, né utilizzare il contenuto o renderlo comunque noto a terzi senza permesso scritto dalla WABCO. È vietata espressamente la ristampa o l'uso non autorizzato. E' vietata espressamente la ristampa o l'uso non autorizzato. Toute réimpression ou utilisation non autorisée sans la permission écrite de la WABCO est formellement interdite. Toute réimpression ou utilisation non autorisée sans la permission écrite de la WABCO est formellement interdite.