

MATING PART
GEGENSTUECK 446 300 329 2 NOT SUPPLIED
PENDANT NICHT IM LIEFERUMFANG
ACCOPPIAMENTO NON FUORNI
INDICATION POUR L'INSTALLATION INDICAZIONE DI MONTAGGIO

INSTALLATION INSTRUCTION
EINBAUHINWEIS
INDICATION POUR L'INSTALLATION INDICAZIONE DI MONTAGGIO

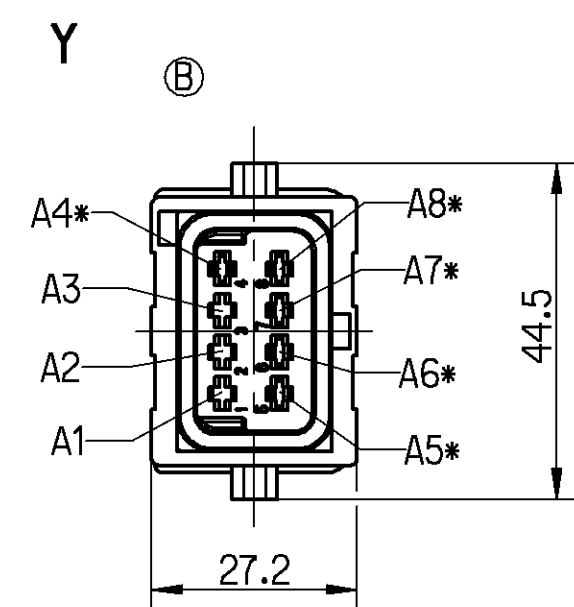
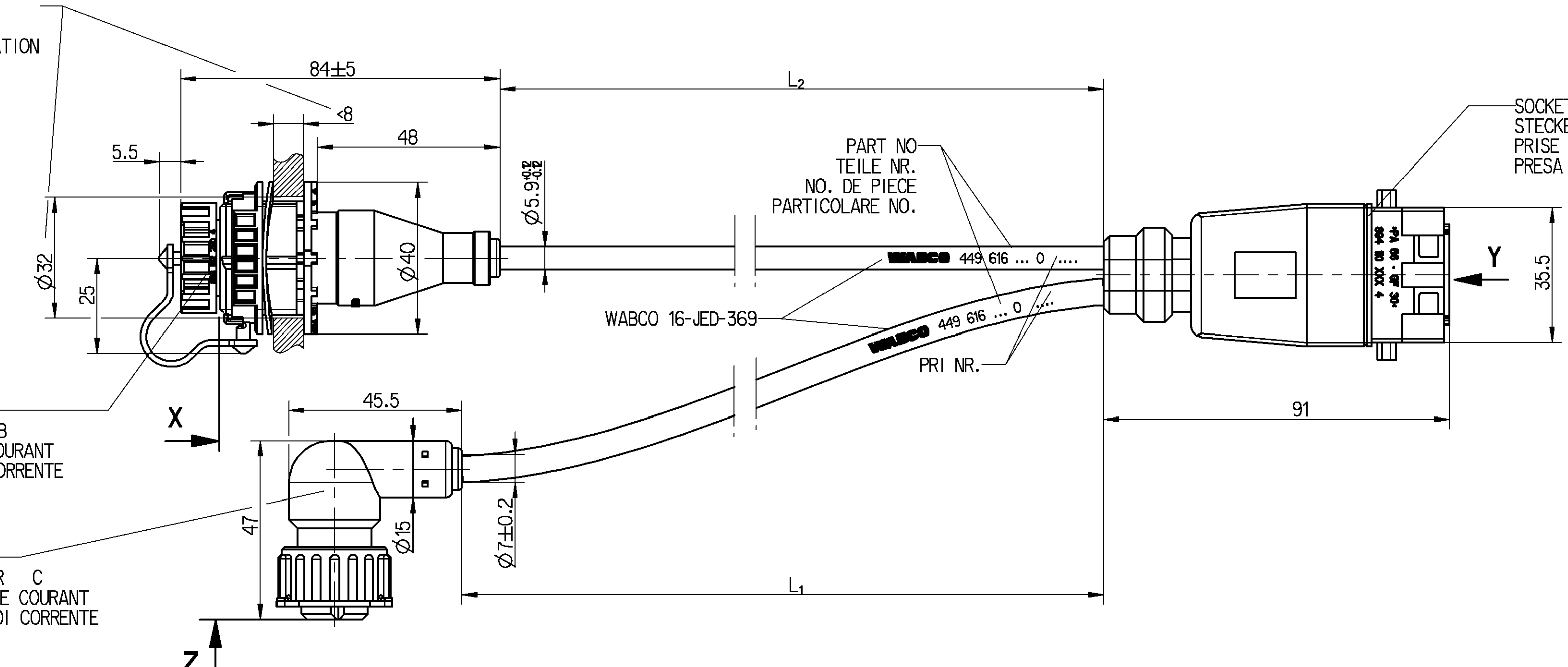

THERMAL RANGE OF APPLICATION
THERMISCHER ANWENDUNGSBEREICH -40 °C...+80 °C
GAMME D'APPLICATION THERMIQUE
CAMPO TERMICO D'APPLICAZIONE

CABLES PUR
KABEL PUR
CABLES PUR
CAVI PUR

DEGREE OF PROTECTION (IN CONNECTION WITH PLUG) :
SCHUTZART (IN VERBINDUNG MIT STECKER) :
DEGRE DE PROTECTION (DANS CONNECTION AVEC FICHE):
GRADO DI PROTEZIONE (IN RELAZIONE CON SPINA) :

A: IP 6K 9K / IP 67
B: IP 6K 9K / IP 67
C: IP 6K 9K / IP 67

SURFACE PROTECTION
OBERFLAECHENSCHUTZ * Sn ** Ag
PROTECTION DE SURFACE
PROTEZIONE SUPERFICI

DATE OF MANUFACTURE : JED-226
HERSTELLDATUM :
DATE DE FABRICATION :
DATA DI FABBRICAZIONE :

RESISTANT TO : AIR, WATER, MINERAL OIL, DIESEL OIL, SALTS/SPRAY
BESTAENDIG GEGEN : LUFT, WASSER, MINERALOEL, BENZIN, DIESEL OEL, SALZSPRUEHNEBEL
RESISTANT A : AIR, EAU, HUILE MINERALE, ESSENCE, GASOIL, BROUILLARD SALIN
RESISTENTE A : ARIA, AQUA, OLIO MINERALE, BENZINA, GASOLIO, NEBBIA SALINA

CHAMBER IN: / KAMMER IN: / KAMMERE EN: / CAMERA IN:	CABLE / KABEL / CABLE / CAVO	WIRE COLOUR / ADER FARBE / FIL COLEURE / FILO COLORE	CHAMBER IN: / KAMMER IN: / KAMMERE EN: / CAMERA IN:	CABLE / KABEL / CABLE / CAVO	WIRE COLOUR / ADER FARBE / FIL COLEURE / FILO COLORE	CHAMBER IN: / KAMMER IN: / KAMMERE EN: / CAMERA IN:
1			B			
2	0.5mm ²	WHITE / WEISS / BLANC / BLANCO	1			
3	0.5mm ²	BROWN / BRAUN / BRUN / BRUNO	7	1.5mm ²	YELLOW/GREEN / GELB/GRUEN / JAUNE/VERT / GIALLO/VERDE	2
4	0.5mm ²	BLUE / BLAU / BLEU / BLU	1	1.5mm ²	BROWN / BRAUN / BRUN / BRUNO	3
5						
6	0.5mm ²	RED / ROT / ROUGE / ROSSO	4			

PART NO. / TEILE NR. / NO. DE PIECE / CODICE	LENGTH / LAENGE / LONGUEUR / LUNGHEZZA / L ₁ [m]	LENGTH / LAENGE / LONGUEUR / LUNGHEZZA / L ₂ [m]
449 616 380 0	0.60	3.00
449 616 381 0	0.60	6.00

CODE OF LENGTH / LAENGCODIERUNG / CODE DE LA LONGUEUR / CODICE DEL LUNGHEZZA : ORDER NUMBER / BESTELLNUMMER / NUMERO DE COMMANDE / NUMERO DELL'ORDINE : 449 616 □□□□ 0
EXAMPLE / BEISPIEL / EXEMPLE / ESEMPIO : L₁ = 2 m / L₂ = 4 m
449 616 186 0

L ₁ [m]	L ₂ [m]	0.25	0.4	1.00	1.35	1.50	2.00	2.50	3.00	3.50	4.00	4.50	5.00	6.00	7.00	8.00	10.0	12.0	15.0	18.0
0.25	0.25	001	002	003	004	005	006	007	008	009	010	011	012	013	014	015	016	017	018	019
0.40	0.40	021	022	023	024	025	026	027	028	029	030	031	032	033	034	035	036	037	038	039
1.00	1.00	041	042	043	044	045	046	047	048	049	050	051	052	053	054	055	056	057	058	059
1.35	1.35	061	062	063	064	065	066	067	068	069	070	071	072	073	074	075	076	077	078	079
1.50	1.50	081	082	083	084	085	086	087	088	089	090	091	092	093	094	095	096	097	098	099
2.00	2.00	101	102	103	104	105	106	107	108	109	110	111	112	113	114	115	116	117	118	119
2.50	2.50	121	122	123	124	125	126	127	128	129	130	131	132	133	134	135	136	137	138	139
3.00	3.00	141	142	143	144	145	146	147	148	149	150	151	152	153	154	155	156	157	158	159
3.50	3.50	161	162	163	164	165	166	167	168	169	170	171	172	173	174	175	176	177	178	179
4.00	4.00	181	182	183	184	185	186	187	188	189	190	191	192	193	194	195	196	197	198	199
4.50	4.50	201	202	203	204	205	206	207	208	209	210	211	212	213	214	215	216	217	218	219
5.00	5.00	221	222	223	224	225	226	227	228	229	230	231	232	233	234	235	236	237	238	239
6.00	6.00	241	242	243	244	245	246	247	248	249	250	251	252	253	254	255	256	257	258	259
7.00	7.00	261	262	263	264	265	266	267	268	269	270	271	272	273	274	275	276	277	278	279
8.00	8.00	281	282	283	284	285	286	287	288	289	290	291	292	293	294	295	296	297	298	299
10.0	10.0	301	302	303	304	305	306	307	308	309	310	311	312	313	314	315	316	317	318	319
12.0	12.0	321	322	323	324	325	326	327	328	329	330	331	332	333	334	335	336	337	338	339
15.0	15.0	341	342	343	344	345	346	347	348	349	350	351	352	353	354	355	356	357	358	359
18.0	18.0	361	362	363	364	365	366	367	368	369	370	371	372	373	374	375	376	377	378	379

MIN/MAX LENGTH / MIN/MAX LAENGE / MIN/MAX LONGUEUR / MIN/MAX LUNGHEZZA	L _{min} = 0.25m L _{max} = 18.00m
TOLERANCES / TOLERANZEN / TOLERANCES / TOLERANZA	L < 10m +0.100 -0.060 L > 10m +0.125 -0.075

GENERAL SPECIFICATION: JED-334-0

PRO/ENGINEER DRAWING COPYRIGHT: WABCO

DATE: 03-09-23
DRAWN: HEYDA
CHECKED: NIEBER
EXPERT CODE: O 5 B

CABLE WITH SOCKET
KABEL MIT GERAEETESTECKDOSE
CABLE AVEC PRISE DE COURANT
CAVO CON PRESA DI CORRENTE

PRODUCT IDENTIFICATION NO.: 449 616 000 0

DOC. CODE: 653 SHEET: 1/1

TAPPED HOLES ACC. ISO 4039 / JED-52
DOF-NO. 0888359 REV. 1xA DATE 03-12-10

1) TOLERANCE CLASS APPLIED CROSS-MARKED

NON E' PERMESSO COPIARE, A REPERE O PAROFRASE, IL CONTENUTO DEL PRESENTE DOCUMENTO SENZA IL CONSENTO SCRITTO DELLA WABCO. IL REPERE O PAROFRASE, SENZA IL CONSENTO SCRITTO DELLA WABCO, E' PENALMENTE PUNIBILE. IL REPERE O PAROFRASE, SENZA IL CONSENTO SCRITTO DELLA WABCO, E' PENALMENTE PUNIBILE. IL REPERE O PAROFRASE, SENZA IL CONSENTO SCRITTO DELLA WABCO, E' PENALMENTE PUNIBILE. IL REPERE O PAROFRASE, SENZA IL CONSENTO SCRITTO DELLA WABCO, E' PENALMENTE PUNIBILE. IL REPERE O PAROFRASE, SENZA IL CONSENTO SCRITTO DELLA WABCO, E' PENALMENTE PUNIBILE.

Drw: 44630000... 653 B.1. INDUSTRIALIZATION