

Non è permesso copiare o terzi o riprodurre questo documento, né utilizzare il contenuto o renderlo comunque noto a terzi senza autorizzazione esplicita. Ogni infrazione costituirà un evidente abuso e comporterà il risarcimento dei danni subiti. È fatta riserva di tutti i diritti derivanti da brevetti o modelli.

Tout le Communication ou reproduction de ce document, toute exploitation ou communication de son contenu sont interdites, sauf autorisation expresse. Tout manquement à cette règle constitue un abus évident et expose son auteur au versement de dommages et intérêts. Tous droits de propriété industrielle réservés, notamment en matière de brevets et de modèles.

Weitergabe sowie Vervielfältigung dieses Unterlagen, Verwertung und Mitteilung ihres Inhalts nicht gestattet, soweit nicht ausdrücklich zugestanden. Zuwiderhandlungen stellen einen offensichtlichen Missbrauch dar und verpflichten zu Schadensersatz. Alle Rechte für den Fall der Patentverletzung oder Gebrauchsmuster-Eintragung vorbehalten.

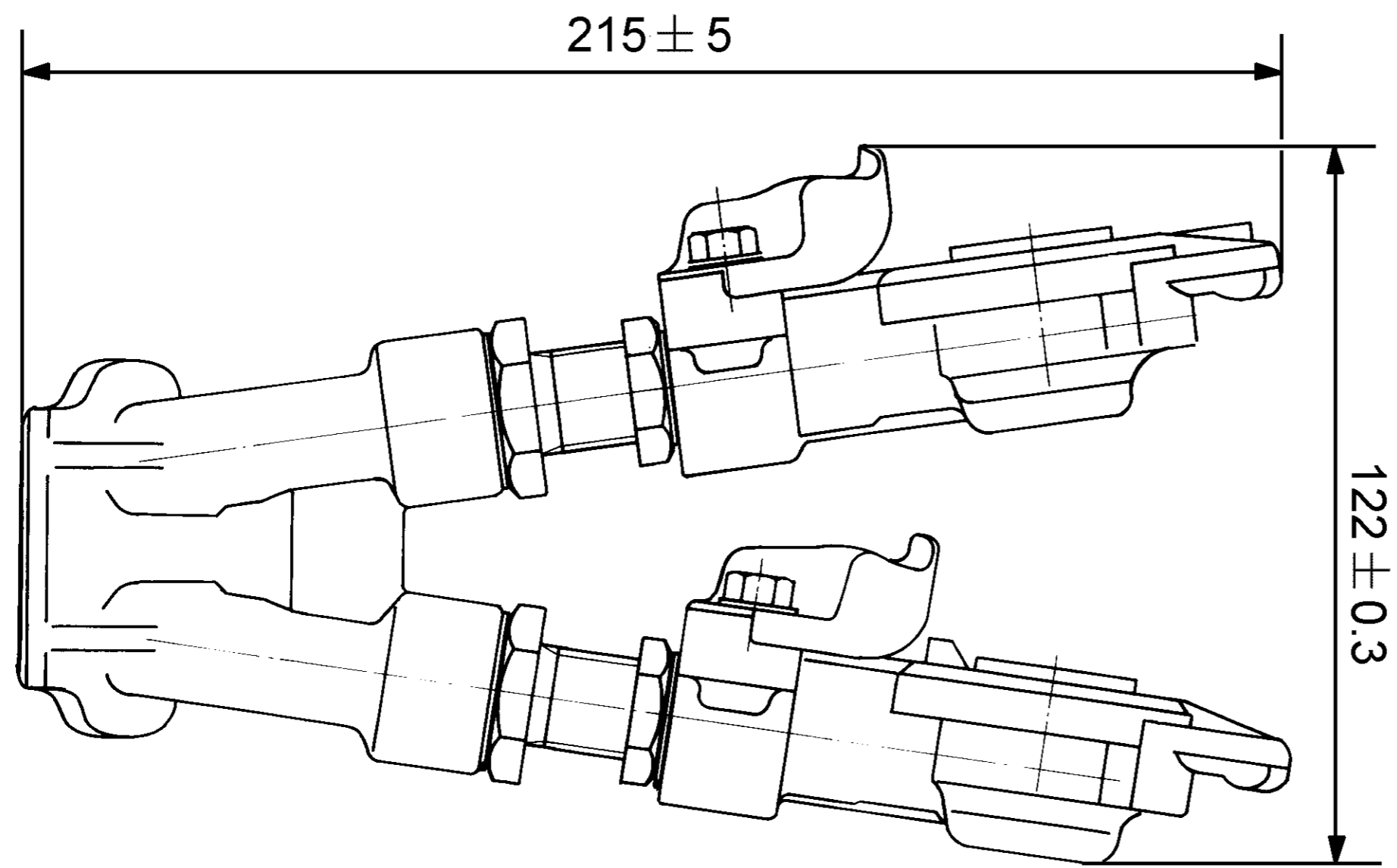

WORKING MEDIUM: COMPRESSED AIR  
 THERMAL RANGE OF APPLICATION: -40 °C ... +80 °C  
 WORKING PRESSURE: 8.5 BAR  
 MAX. PERMISSIBLE PRESSURE: 10 BAR

FURTHER TECHNICAL DATA SEE:  
 452 802 000 0 DOC.035  
 952 200 000 0 DOC.035  
 952 201 000 0 DOC.035  
 ISO 1728

General Specification: JED-334-0		Copyright WABCO®		<b>WABCO</b> QUICK COUPLING				
Further Technical Data:		Date	Signature				Date of first issue: 2011-09-22	
Doc. Code:	Sheet: To	2011-09-22	BALAGA				Doc. Code	Language
General Tolerances JED-261		2011-09-22	HLADIK				005	EN
Range of Nominal Dimensions ( ± mm)		Expert		Sheet				
Class 1)	≤ 50	> 50 ≤ 180	> 180 ≤ 400	> 400	±3°			
Fine	0.5	1.0	1.5	2.0	1/1			
Medium	X 1.0	2.0	3.0	4.0				
Coarse	2.0	3.5	5.0	6.5				
Tapped Holes acc. JED-152		Mass	Scale	Material No.				
1) Tolerance Class Applied Crossmarked		KG	1:1	452 204 910 0				
		Size	CAD System	Date of first issue: 2011-09-22				
		A 3	Pro/E	Doc. Code	Language			
		ECON-No.		Revision	Techn. Resp.			
		-		-	5711			
		Replacement for		-				

100mm