

TORQUE FOR CONNECTIONS
ANZUGSMOMENT FUER SCHRAUBSTUTZEN
COUPLE DE SERRAGE DES RACCORDS
COPPIA DI SERRAGGIO DEI RACCORDI

1	SUPPLY VORRAT ALIMENTATION ALIMENTAZIONE	13 N.m MAX
41	PILE DRIVING STEUERDRUCK PILOTAGE PILOTAGGIO	13 N.m MAX
21 22	USE AUSGANG UTILISATION UTILIZZAZIONE	SYMBOL SYMBOL SIMBOLE SIMBOLO
3	AIR EXHAUST UPWARD ENTLUEFTUNG ECHAPPEMENT VERS LE HAUT SCARICO	

INSTALLATION POSITION
EINBAULAGE
POSITION DE MONTAGE
POSIZIONE DI MONTAGGIO

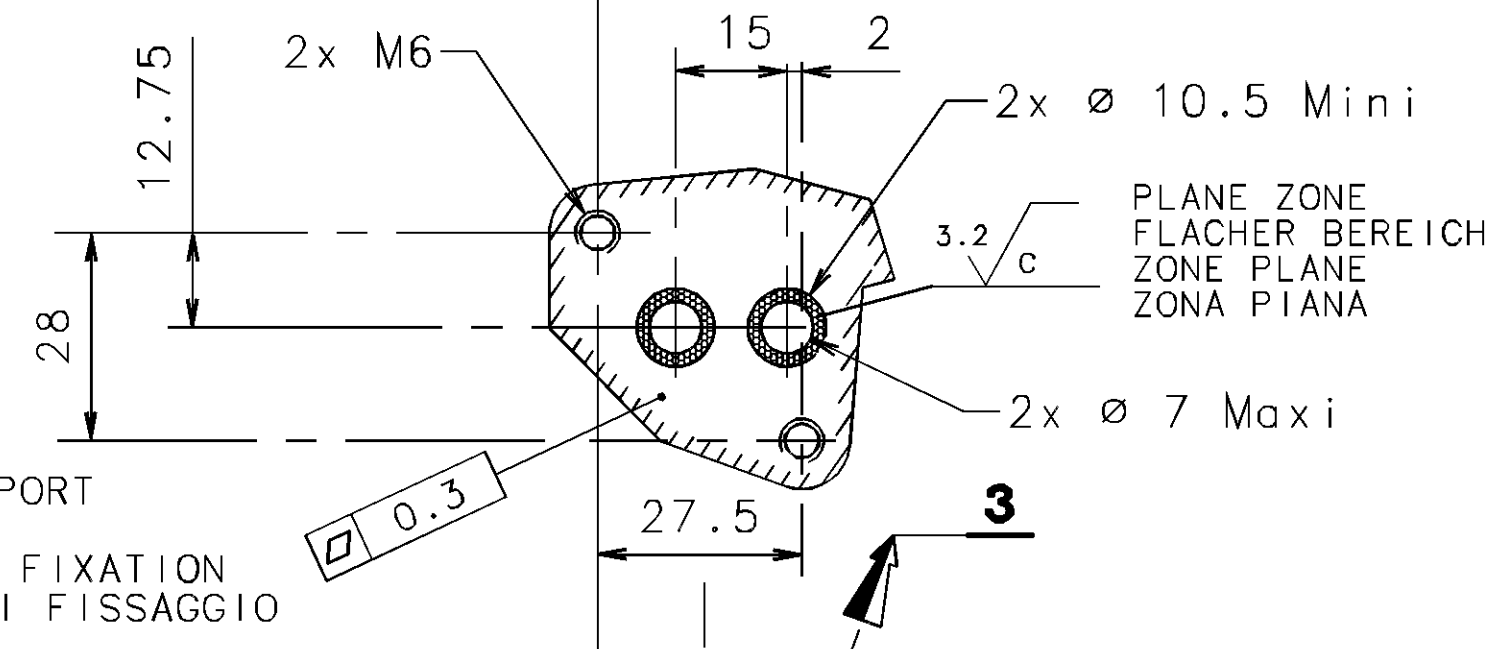

FIXING SUPPORT
SUPPORT DE FIXATION
SUPPORTO DI FISSAGGIO

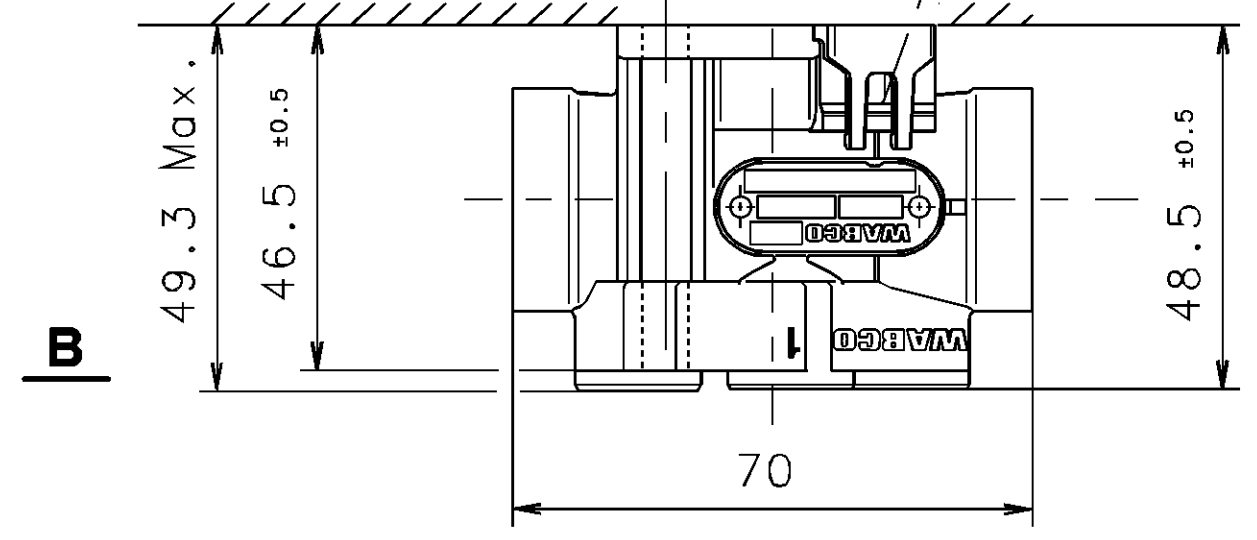

VIEW
ANSICHT
VUE
VISTA

SUPPLY PRESSURE
VORRATSDRUCK
PRESSION PNEUMATIQUE D'ALIMENTATION
PRESSIONE PNEUMATICA DI ALIMENTAZIONE

PILOT PRESSURE
STEUERDRUCK
PRESSION DE PILOTAGE
PRESSIONE DI PILOTAGGIO

THERMAL RANGE
THERM. ANWENDUNGSBEREICH
TEMPERATURE D'UTILISATION
TEMPERATURA DI UTILIZZAZIONE

SEE DOCUMENT Code 335
VOIR

III	JED 070 M1	
II	PPS	
I	JED 029 M3	JED 259
	- MATERIAL	- SURFACE PROTECTION
	- MATIERE	- PROTECTION DE SURFACE

DEVICE MUST NOT BE OPERATED BEFORE INSTALLATION
GERAET NICHT VOR MONTAGE BETAETIGEN
NE PAS ACTIONNER L'APPAREIL AVANT MONTAGE
NON AZIONERE IL APPARECCHIO PRIMA MONTAGGIO

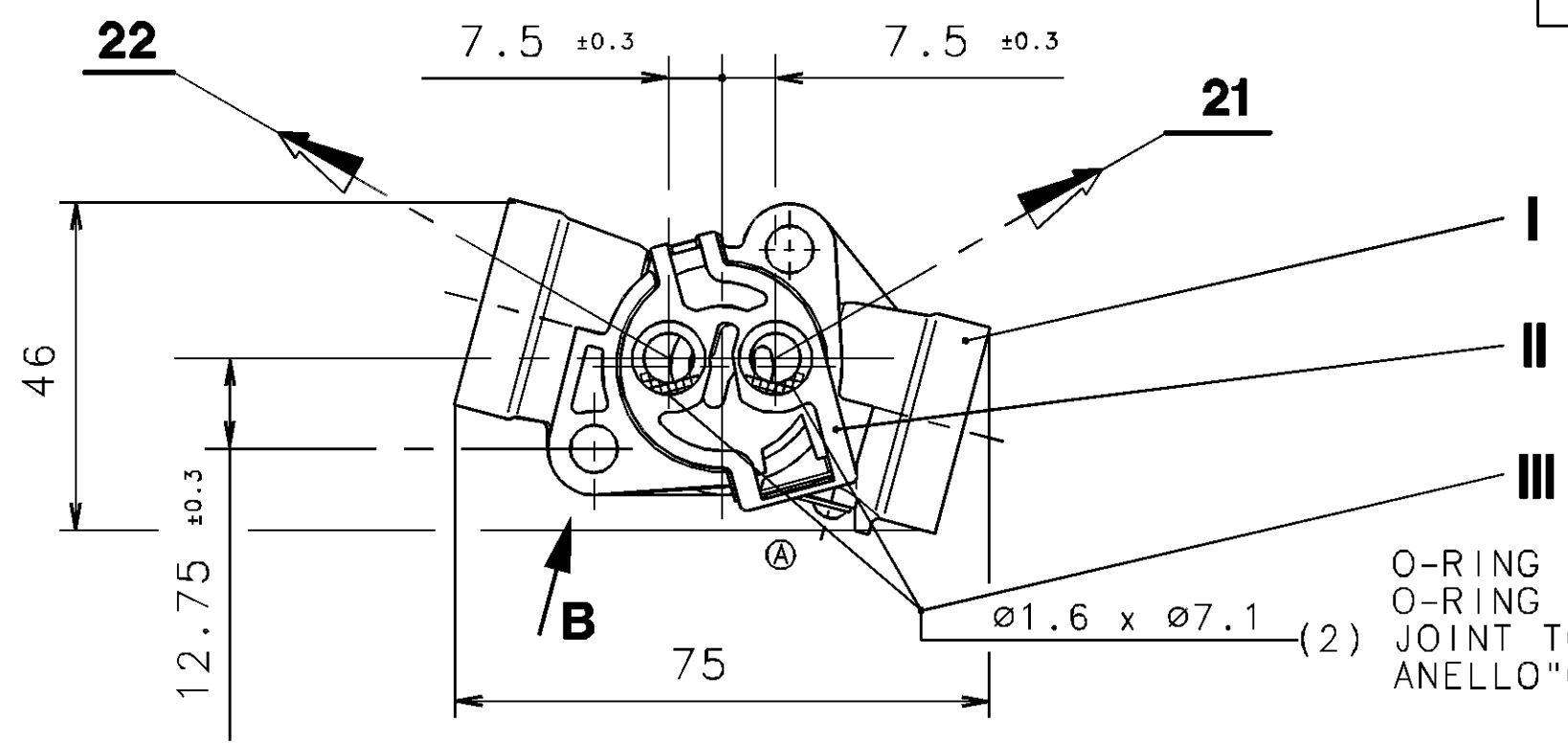

FURTHER TECHNICAL DATA SEE		L	COPYRIGHT	
IDENTIFICATION NO.:		K	DATE	SIGNATURE
CODE FOR DOCUMENT: 605 SHEET: TO		J	94-08-17	HOUDART
GENERAL TOLERANCES		H	DRAWN	
CLASS	RANGE OF NOMINAL DIMENSIONS (± mm)	G	94-08-30	L'HER
		F	CHECKED	
I	≤50	E	STANDARDIZATION	
II	>50 ≤180	D	94-09-01	94 166
III	>180 ≤400	C	MASS SCALE	
	>400	B	kg	1:1
TAPPED HOLES ACC. ISO 4039 / JED-152		A	SIZE	T.R.I.
1) TOLERANCE CLASS APPLIED CROSSMARKED			A 2	210
95 087	1 x (A) 95-03-30	PRODUCT IDENTIFICATION NO.		
DCN-NO.	REV.	DATE	WABCO	
			4/2 SLIDE VALVE	
			4/2 SCHIEBERVENTIL	
			DISTRIBUTEUR 4/2 (MONOSTABLE)	
			VALVOLA 4/2	
			CODE FOR DOCUMENT	SHEET
			605	1/1
			REPLACEMENT FOR	

NON E' PERMESSO CONSERVARE A TERZO O RIPRODURRE QUESTO DOCUMENTO, NE UTILIZZARNE IL CONTENUTO O RENDERSI
 COME NOTE A TERZO SENZA AUTORIZZAZIONE ESPlicitA. CON INFRAZIONE COSTITUISCA UN EVIDENTE ABUSO E
 DEL DANNI SUBITO. LA TALE RISERVA DI TUTTI I DIRITTI. DEVIANTI DUBBIEZZE O MODELLI.
 COPIING OF THIS DOCUMENT, AND GIVING IT TO OTHERS AND THE USE OR COMMUNICATION OF THE
 CONTENTS THEREOF, ARE FORBIDDEN WITHOUT EXPRESS AUTHORITY. CONTRAVENTION OF THIS RESTRICTION WILL
 BE CONSIDERED AS AN EVIDENT ABUSE AND RESULT IN A LIABILITY TO THE PAYMENT OF DAMAGES. ALL RIGHTS ARE
 RESERVED IN THE EVENT OF THE GRANT OF A PATENT OR THE REGISTRATION OF AN UTILITY MODEL OR DESIGN.
 THIS DRAWING IS SUBJECT TO COPYRIGHT.