

	MATERIAL	SURFACE PROTECTION
I	POM	
II	EPDM	
III	STEEL	Zn
IV	STEEL	Zn
V	COMPOSITE PLASTIC	
VI	STEEL	Zn
VII	STEEL	Zn
VIII	PA 6.6 30GF	

VARIANT: 464 007 047 0 - USING "HARD SPRING F=300 N"

FLOW RATE FOR : P1=8 bar and P1=11 bar

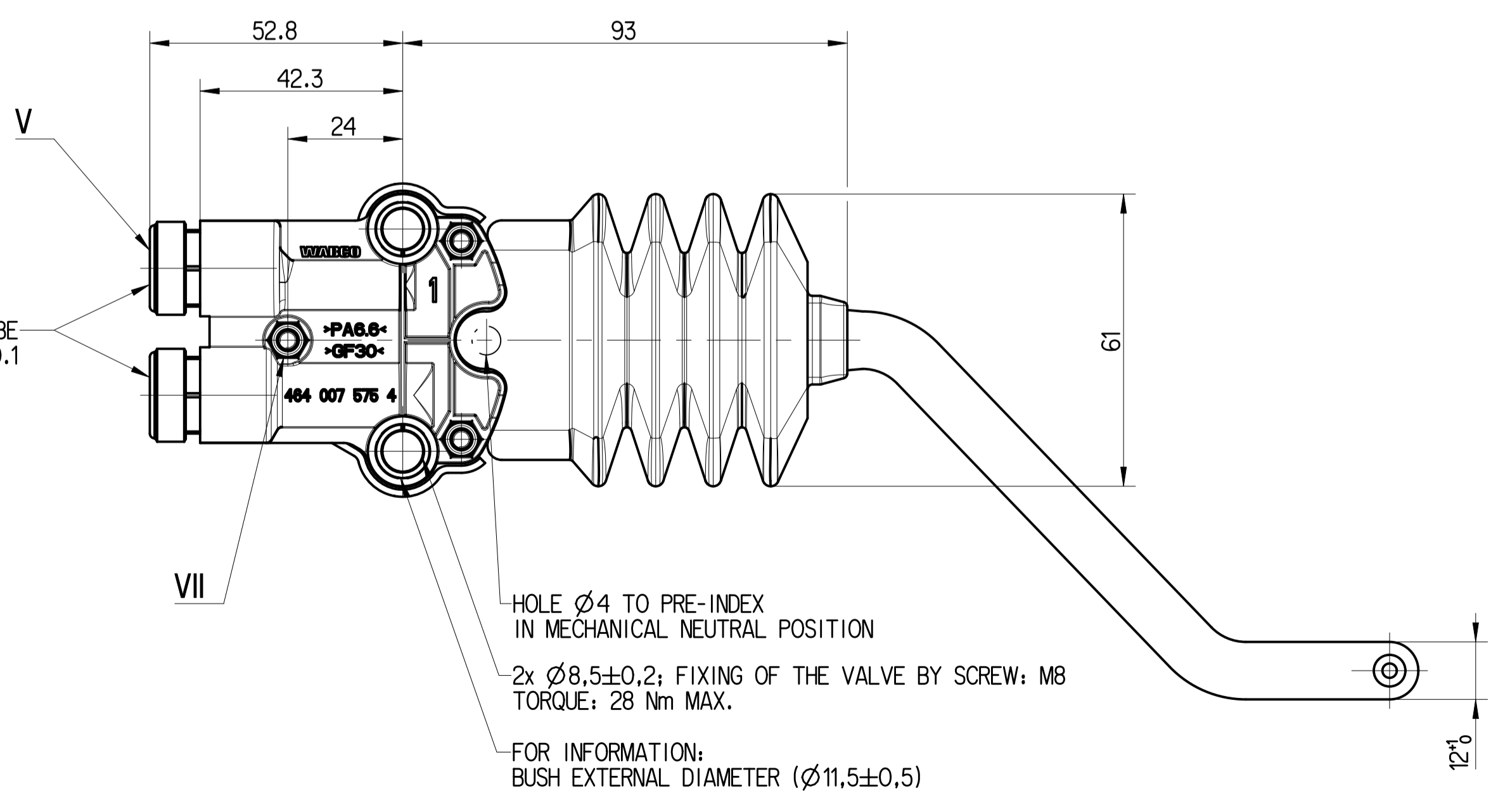
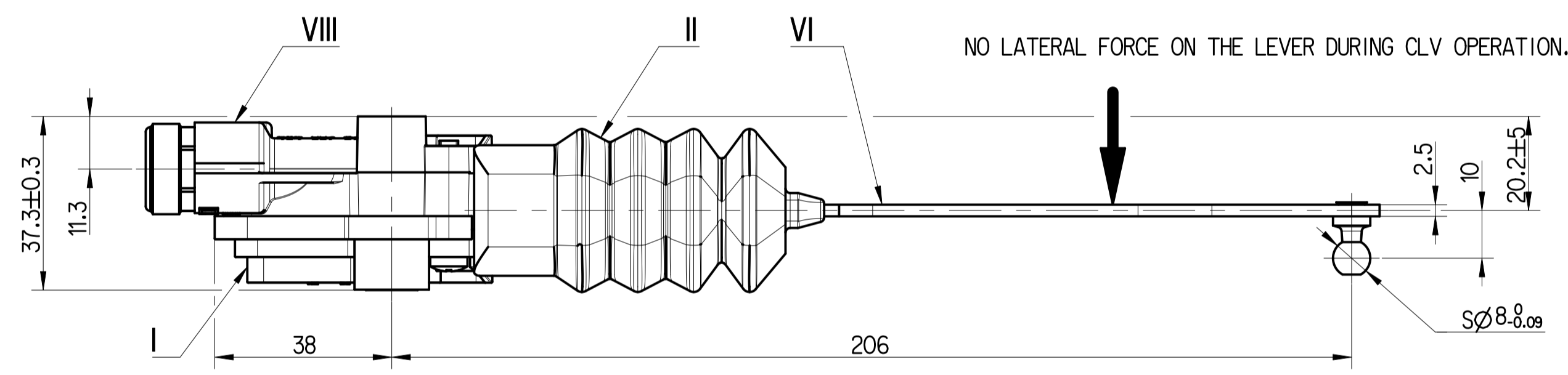
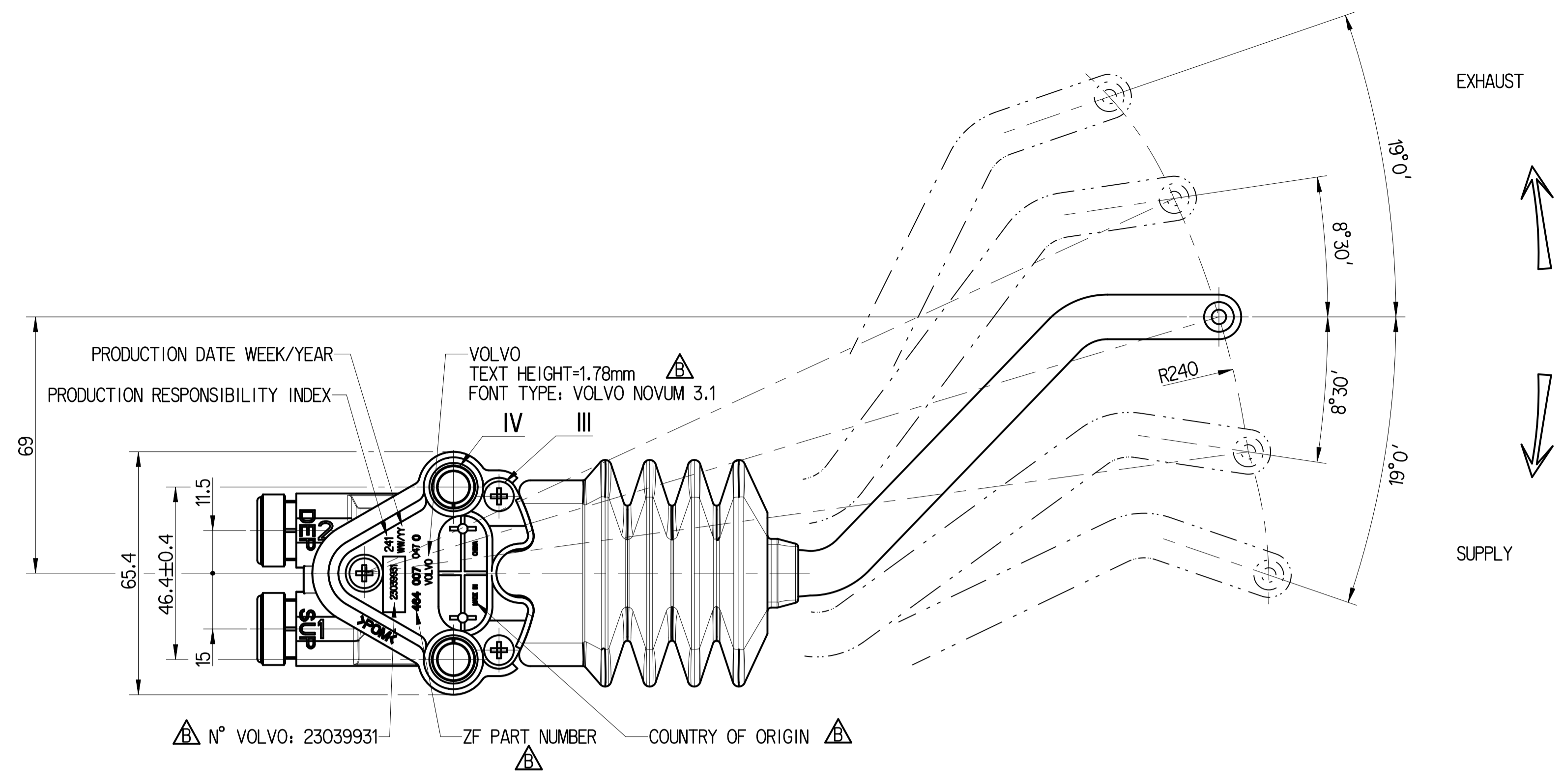
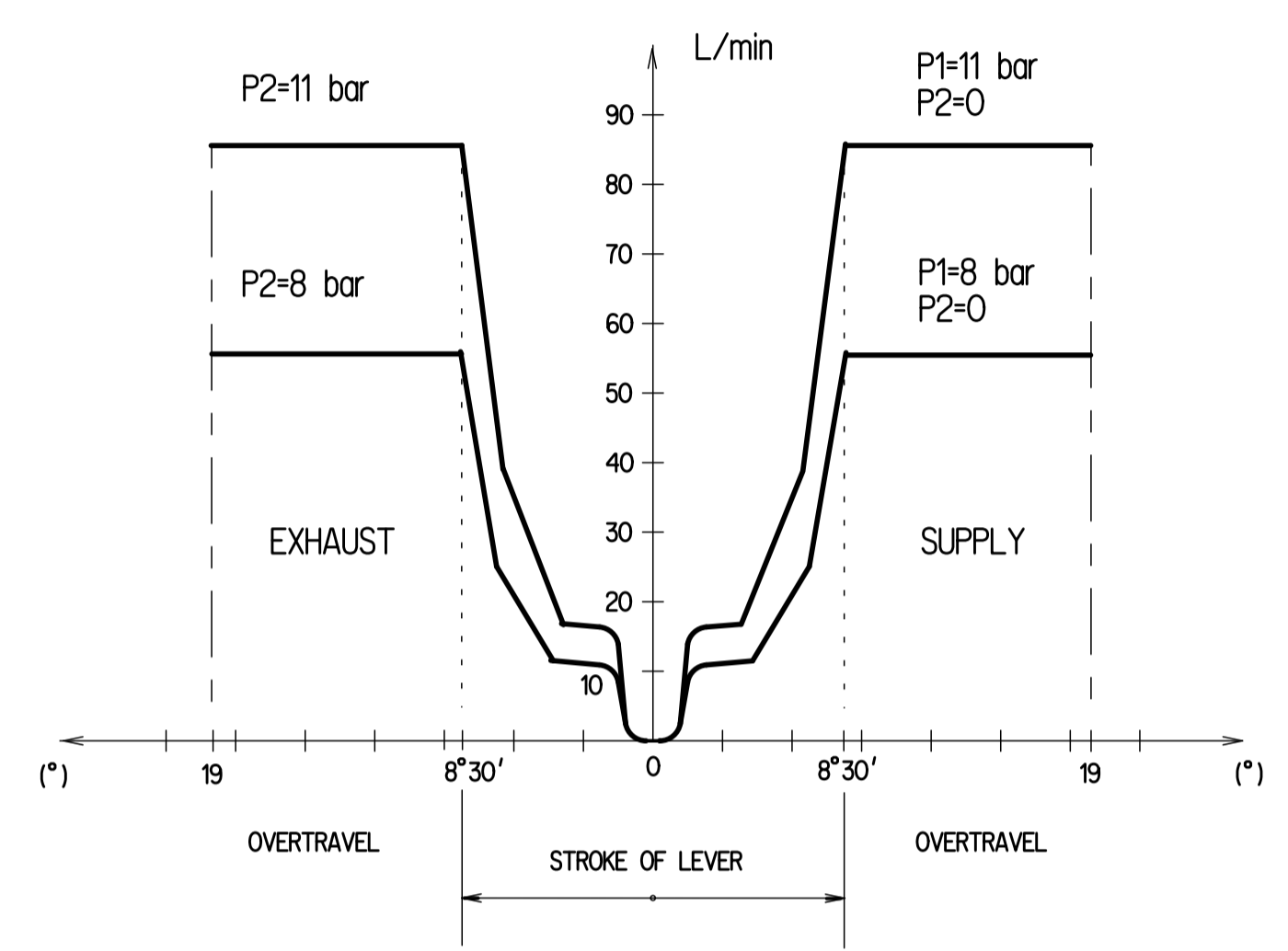

RAUFOSS ABC SMALL KARTRIDGE FOR PLASTIC TUBE
RECOMMENDED EXTERNAL TUBE DIAMETER $\phi 6 \pm 0.1$

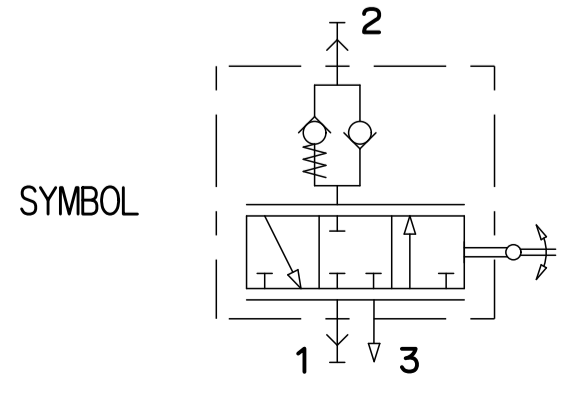

1	SUPPLY
2	DELIVERY
THERMAL RANGE	-45°C ... +100°C
WORKING PRESSURE	P1= 13 bar MAX.
EXCEPTIONAL INLET PRESSURE	P1= 14 bar MAX.
RESIDUAL PRESSURE	P2= 0.6±0.3 bar

General Specifications: ISO 8075, JED-334-1, Size ISO 14405 LP		Copyright ZF®	
Further Technical Data:		Date	Signature
Doc. Code:	Sheet: To	2026-03-10	Yue
General Tolerances JED-261		Checked	Zak
Range of nominal dimensions in mm		Dimensions in mm	
Class	1) ≤ 50	> 50	> 180
	±0.5	±1	±1.5
	±1	±2	±3
	±2	±3.5	±5
	±3	±5	±6.5
	±4	±6	±8
	±5	±8	±10
	±6	±10	±12
	±7	±12	±15
	±8	±15	±20
	±10	±20	±25
	±12	±25	±30
	±15	±30	±35
	±20	±40	±50
	±25	±50	±60
	±30	±60	±75
	±40	±80	±100
	±50	±100	±125
	±60	±125	±150
	±75	±150	±180
	±90	±180	±220
	±110	±220	±270
	±130	±270	±330
	±150	±330	±400
	±180	±400	±500
	±220	±500	±630
	±270	±630	±800
	±330	±800	±1000
	±400	±1000	±1250
	±500	±1250	±1600
	±630	±1600	±2000
	±800	±2000	±2500
	±1000	±2500	±3150
	±1250	±3150	±4000
	±1600	±4000	±5000
	±2000	±5000	±6300
	±2500	±6300	±8000
	±3150	±8000	±10000
	±4000	±10000	±12500
	±5000	±12500	±16000
	±6300	±16000	±20000
	±8000	±20000	±25000
	±10000	±25000	±31500
	±12500	±31500	±40000
	±16000	±40000	±50000
	±20000	±50000	±63000
	±25000	±63000	±80000
	±31500	±80000	±100000
	±40000	±100000	±125000
	±50000	±125000	±160000
	±63000	±160000	±200000
	±80000	±200000	±250000
	±100000	±250000	±315000
	±125000	±315000	±400000
	±160000	±400000	±500000
	±200000	±500000	±630000
	±250000	±630000	±800000
	±315000	±800000	±1000000
	±400000	±1000000	±1250000
	±500000	±1250000	±1600000
	±630000	±1600000	±2000000
	±800000	±2000000	±2500000
	±1000000	±2500000	±3150000
	±1250000	±3150000	±4000000
	±1600000	±4000000	±5000000
	±2000000	±5000000	±6300000
	±2500000	±6300000	±8000000
	±3150000	±8000000	±10000000
	±4000000	±10000000	±12500000
	±5000000	±12500000	±16000000
	±6300000	±16000000	±20000000
	±8000000	±20000000	±25000000
	±10000000	±25000000	±31500000
	±12500000	±31500000	±40000000
	±16000000	±40000000	±50000000
	±20000000	±50000000	±63000000
	±25000000	±63000000	±80000000
	±31500000	±80000000	±100000000
	±40000000	±100000000	±125000000
	±50000000	±125000000	±160000000
	±63000000	±160000000	±200000000
	±80000000	±200000000	±250000000
	±100000000	±250000000	±315000000
	±125000000	±315000000	±400000000
	±160000000	±400000000	±500000000
	±200000000	±500000000	±630000000
	±250000000	±630000000	±800000000
	±315000000	±800000000	±1000000000
	±400000000	±1000000000	±1250000000
	±500000000	±1250000000	±1600000000
	±630000000	±1600000000	±2000000000
	±800000000	±2000000000	±2500000000
	±1000000000	±2500000000	±3150000000
	±1250000000	±3150000000	±4000000000
	±1600000000	±4000000000	±5000000000
	±2000000000	±5000000000	±6300000000
	±2500000000	±6300000000	±8000000000
	±3150000000	±8000000000	±10000000000
	±4000000000	±10000000000	±12500000000
	±5000000000	±12500000000	±16000000000
	±6300000000	±16000000000	±20000000000
	±8000000000	±20000000000	±25000000000
	±10000000000	±25000000000	±31500000000
	±12500000000	±31500000000	±40000000000
	±16000000000	±40000000000	±50000000000
	±20000000000	±50000000000	±63000000000
	±25000000000	±63000000000	±80000000000
	±31500000000	±80000000000	±100000000000
	±40000000000	±100000000000	±125000000000
	±50000000000	±125000000000	±160000000000
	±63000000000	±160000000000	±200000000000
	±80000000000	±200000000000	±250000000000
	±100000000000	±250000000000	±315000000000
	±125000000000	±315000000000	±400000000000
	±160000000000	±400000000000	±500000000000
	±200000000000	±500000000000	±630000000000
	±250000000000	±630000000000	±800000000000
	±315000000000	±800000000000	±1000000000000
	±400000000000	±1000000000000	±1250000000000
	±500000000000	±1250000000000	±1600000000000
	±630000000000	±1600000000000	±2000000000000
	±800000000000	±2000000000000	±2500000000000
	±1000000000000	±2500000000000	±3150000000000
	±1250000000000	±3150000000000	±4000000000000
	±1600000000000	±4000000000000	±5000000000000
	±2000000000000	±5000000000000	±6300000000000
	±2500000000000	±6300000000000	±8000000000000
	±3150000000000	±8000000000000	±10000000000000
	±4000000000000	±10000000000000	±12500000000000
	±5000000000000	±12500000000000	±16000000000000
	±6300000000000	±16000000000000	±20000000000000
	±8000000000000	±20000000000000	±25000000000000
	±10000000000000	±25000000000000	±31500000000000
	±12500000000000	±31500000000000	±40000000000000
	±16000000000000	±40000000000000	±50000000000000
	±20000000000000	±50000000000000	±63000000000000
	±25000000000000	±63000000000000	±80000000000000
	±31500000000000	±80000000000000	±100000000000000
	±40000000000000	±100000000000000	±125000000000000
	±50000000000000	±125000000000000	±160000000000000
	±63000000000000	±160000000000000	±200000000000000
	±80000000000000	±200000000000000	±250000000000000
	±100000000000000	±250000000000000	±315000000000000
	±125000000000000	±315000000000000	±400000000000000
	±160000000000000	±400000000000000	±500000000000000
	±200000000000000	±500000000000000	±630000000000000
	±250000000000000	±630000000000000	±800000000000000
	±315000000000000	±800000000000000	±1000000000000000
	±400000000000000	±1000000000000000	±1250000000000000
	±500000000000000	±1250000000000000	±1600000000000000
	±630000000000000	±1600000000000000	±2000000000000000
	±800000000000000	±2000000000000000	±2500000000000000
	±1000000000000000	±2500000000000000	±3150000000000000
	±1250000000000000	±3150000000000000	±4000000000000000
	±1600000000000000	±4000000000000000	±5000000000000000
	±2000000000000000	±5000000000000000	±6300000000000000
	±2500000000000000	±6300000000000000	±8000000000000000
	±3150000000000000	±8000000000000000	±10000000000000000
	±4000000000000000	±10000000000000000	±12500000000000000
	±5000000000000000	±12500000000000000	±16000000000000000
	±6300000000000000	±16000000000000000	±20000000000000000
	±8000000000000000	±20000000000000000	±25000000000000000
	±10000000000000000	±25000000000000000	±31500000000000000
	±12500000000000000	±31500000000000000	±40000000000000000
	±16000000000000000	±40000000000000000	±50000000000000000
	±20000000000000000	±50000000000000000	±63000000000000000
	±25000000000000000	±63000000000000000	±80000000000000000
	±31500000000000000	±80000000000000000	±100000000000000000
	±40000000000000000	±100000000000000000	±125000000000000000
	±50000000000000000	±125000000000000000	±160000000000000000
	±63000000000000000	±160000000000000000	±200000000000000000
	±80000000000000000	±200000000000000000	±250000000000000000
	±100000000000000000	±250000000000000000	±315000000000000000
	±125000000000000000	±315000000000000000	±400000000000000000
	±160000000000000000	±400000000000000000	±500000000000000000