

MATERIAL AND SURFACE PROTECTION					
a	PA 6.6	e	PA6.6 35% GF	j	PA 6.6 35% GF
b	ZN / C	f	SI / ZN	k	AL
c	8.8 / ZN	g	SI / painted		
d	PA 6T/6I 30% GF	h	10.9 / ZN		

THE VALVE CORRESPONDS TO THE REGULATIONS FOR ELECTROMAGNETIC DEVICES ACCORDING TO VDE 0580
 DAS GERÄT ENTSPRICHT DEN BESTIMMUNGEN FÜR ELEKTROMAGNETISCHE GERÄTE NACH VDE 0580
 LA VALVE CORRESPOND AUX CONDITIONS POUR DES APPAREILS ELECTROMAGNETIQUES SUIVANT VDE 0580
 LA VALVOLA CORRISPONDE ALLE CONDIZIONI PER APPARECCHI ELEKTROMAGNETICI DECONDO VDE 0580

1.1 WORKING MEDIUM : AIR (CONTAINING WATER, OIL AND ALCOHOL)
 ARBEITSMEDIUM : LUFT (WASSER-, OEL- UND ALKOHOLHALTIG)
 FLUIDE D'UTILISATION : AIR (CHARGE D'EAU, D'HUILE ET D'ALCOOL)
 FLUIDO DI ESERCIZIO : ARIA (CONTENENTE ACQUA, OLIO ED ALCOOL)

1.2 AMBIENT MEDIUM : AIR (CONTAINING WATER AND SALT)
 UMGEBUNGSMEDIUM : LUFT (WASSER- UND SALZHALTIG)
 FLUIDE AMBIANT : AIR (CHARGE D'EAU ET DE SEL)
 FLUIDO AMBIENTE : ARIA (CONTENENTE ACQUA ED SALE)

2.1 THERMAL RANGE OF APPLICATION UNDER NORMAL AMBIENT CONDITIONS : -40°C...+80°C
 THERMISCHER ANWENDUNGSBEREICH UNTER NORMALEN UMGEBUNGSBEDINGUNGEN :
 GAMME D'APPLICATION THERMIQUE DANS CONDITIONS AMBIENTES NORMALES :
 CAMPO TERMICO D'APPLICAZIONE NELLE NORMALI CONDIZIONI AMBIENTALI :

2.2 SHORT TERM RESISTANCE TO HEAT :
 KURZZEITIGE WAERMEBESTAENDIGKEIT : MAX. 1h AT 110°C
 RESISTANCE THERMIQUE TEMPORAIRE :
 RESISTANZA TERMICA PER BREVE PERIODO :

3.1 WORKING PRESSURE (SUPPLY) :
 BETRIEBSDRUCK (VORRAT) : $p_e = 5...13$ bar
 PRESSION D'UTILISATION (ALIMENTATION) :
 PRESSIONE DI ESERCIZIO (ALIMENTAZIONE) :

3.2 MAX. DYNAMIC PRESSURE (DELIVERY) :
 MAX. DYNAMISCHER DRUCK (ARBEITSLAUF) : $p_e = 20$ bar
 PRESSION DYNAMIQUE MAXI.(UTILISATION) :
 PRESSIONE DINAMICA MAX. (MANDATA) :

4.1 MIN. FLOW PASSAGE /NOMINAL DIAMETER
 MIN. DURCHFLOSSEFFNUNG /NENNWEITE
 MIN. ORIFICE CALIBRE /DIAMETRE NOMINAL
 MIN. PASSAGGIO LIBERO /DIAMETRO NOMINALE

4.2 PORT 3,11,21 :
 ANSCHLUSS 3,11,21 : $75 \text{ mm}^2 (= \varnothing 9.8 \text{ mm})$
 ORIFICE 3,11,21 :
 ORIFIZIO 3,11,21 :

4.3 PORT 22,23 : 4.4 THROTTLE :
 ANSCHLUSS 22,23 : 38.5 mm^2 DROSSEL : 0.28 mm^2
 ORIFICE 22,23 : (= $\varnothing 7 \text{ mm}$) ETRANGLEUR : (= $\varnothing 0.6 \text{ mm}$)
 ORIFIZIO 22,23 : STROZZAMENTO :

5 TYPE OF CURRENT : DIRECT CURRENT
 STROMART : GLEICHSTROM
 NATURE DU COURANT : COURANT CONTINU
 NATURA DELLA CORRENTE: CORRENTE CONTINUA

6 MAINTENANCE REQUIREMENTS: NONE
 WARTUNGSANFORDERUNGEN : KEINE
 ENTRETIEN : NON
 MANUTENZIONE : NON

7 OPERATING VOLTAGE :
 BETRIEBSSTROMUNG : 24V $\pm 5\%$
 TENSION DE SERVICE : -4.4V
 TENSIONE DI SERVIZIO :

8 INSTALLATION LIMITATIONS : DIRECTION A, B OR C MAY POINT UPWARDS
 EINBAUESCHRAENKUNGEN : RICHTUNG A, B ODER C NACH OBEN ZULAESSIG
 RESTRICTIONS D'INSTALLATION : DIRECTION A, B OU C PEUT ETRE ORIENTEE VERS LE HAUT
 LIMITAZIONE DI MONIAGGIO : DIREZIONE A, B O C ORIENTATA VERSO L'ALTO AMMESSA

9 SERVICE CONDITION : CONTINUOUS OPERATION
 BETRIEBSART : DAUERBETRIEB
 CONDITION DU SERVICE : SERVICE CONTINU
 CONDIZIONE DI SERVIZIO: SERVIZIO CONTINUO

10 SECURITY AGAINST THE CONFUSING OF POLES: EXISTING
 VERPOLSICHERHEIT : VORHANDEN
 DISPOSITIF DE TROMPEUR DE POLES : EXISTANT
 SICUREZZA CONTRO L'INVERSIONE DEI POLI : ESISTENTE

11 RATED CURRENT AT ROOM TEMPERATURE :
 NENNSTROM BEI RAUMTEMPERATUR : $I_N = 0.32 \text{ A}$
 COURANT NOMINAL A LA TEMPERATURE AMBIANTE :
 CORRENTE NOMINALE ALLA TEMPERATURA AMBIENTE :

12 I_{min} at room temperature (per coil): 0.24A
 I_{min} bei Raumtemperatur (je Spule): 0.24A
 I_{min} a temperature ambiante (par bobine): 0.24A
 I_{min} a temperatura ambiente (per bobina): 0.24A

13 I_{max} at room temperature (per coil): 0.42A
 I_{max} bei Raumtemperatur (je Spule): 0.42A
 I_{max} a temperature ambiante (par bobine): 0.42A
 I_{max} a temperatura ambiente (per bobina): 0.42A

14 DEGREE OF PROTECTION ACCORDING TO DIN 40050:
 SCHUTZART NACH DIN 40050 : IP 6K9K, IP 6K6K
 DEGRE DE PROTECTION SUIVANT DIN 40050 :
 GRADO DI PROTEZIONE SECONDO DIN 40050 :

15 PROTECTION CLASS :
 SCHUTZKLASSE : III
 CLASSE DE PROTECTION:
 CLASSE DI PROTEZIONE :

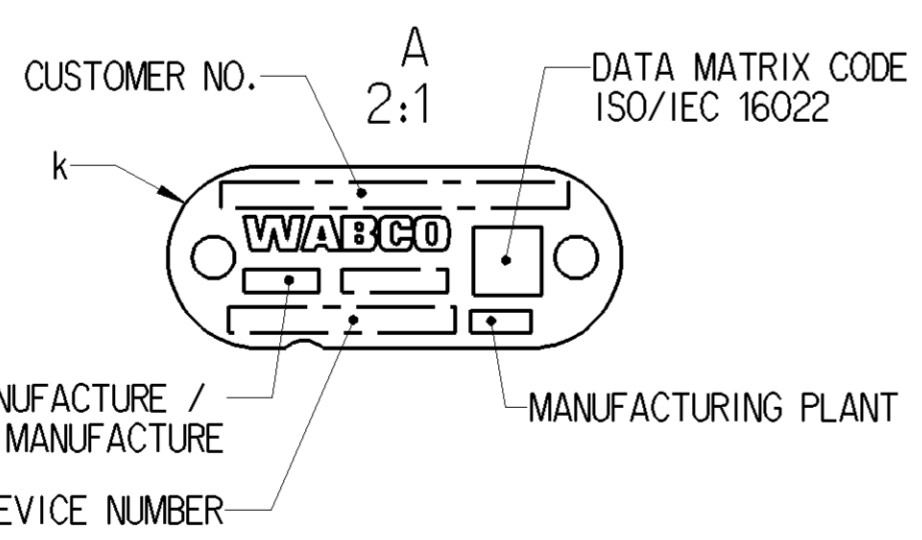
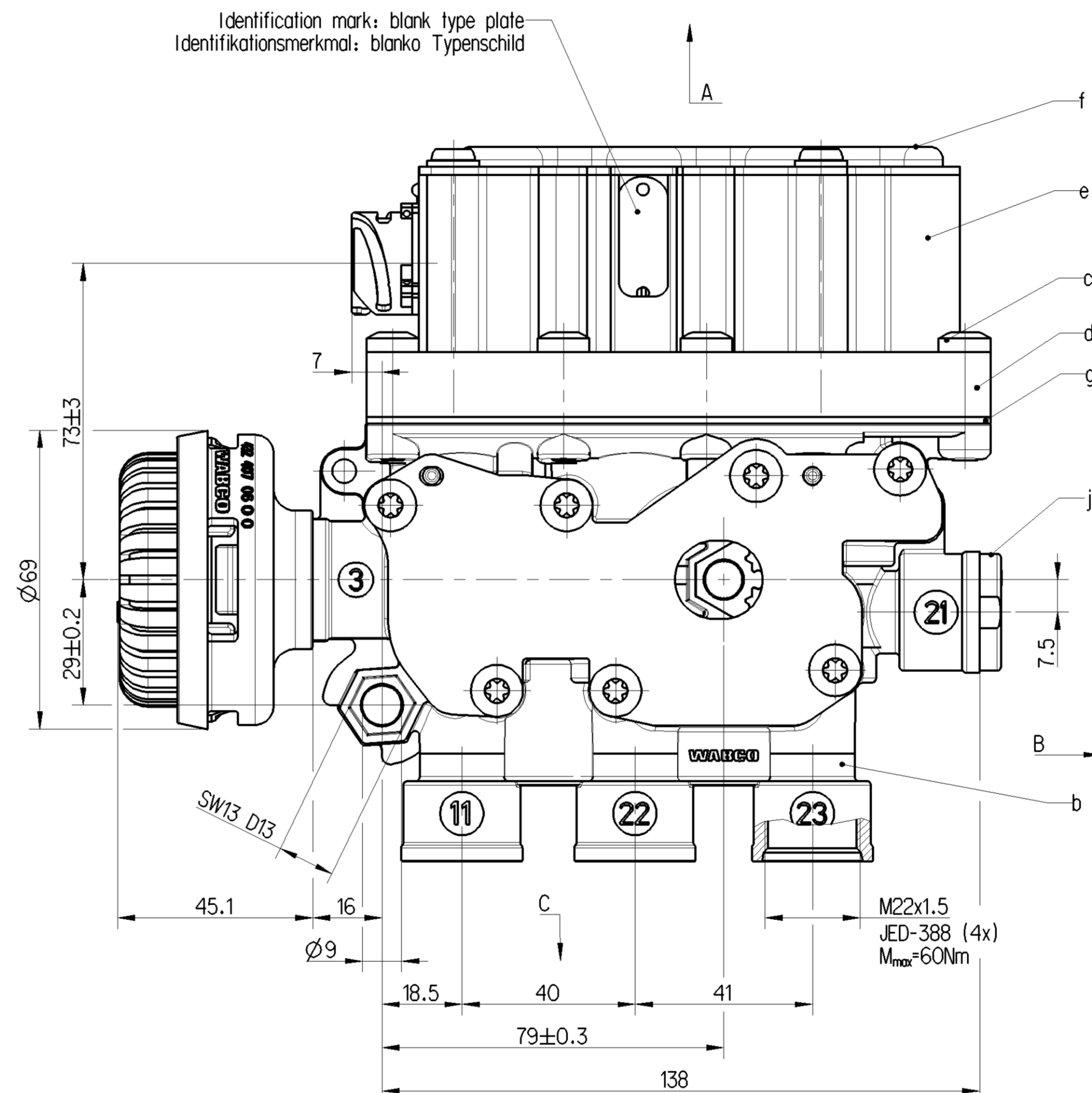
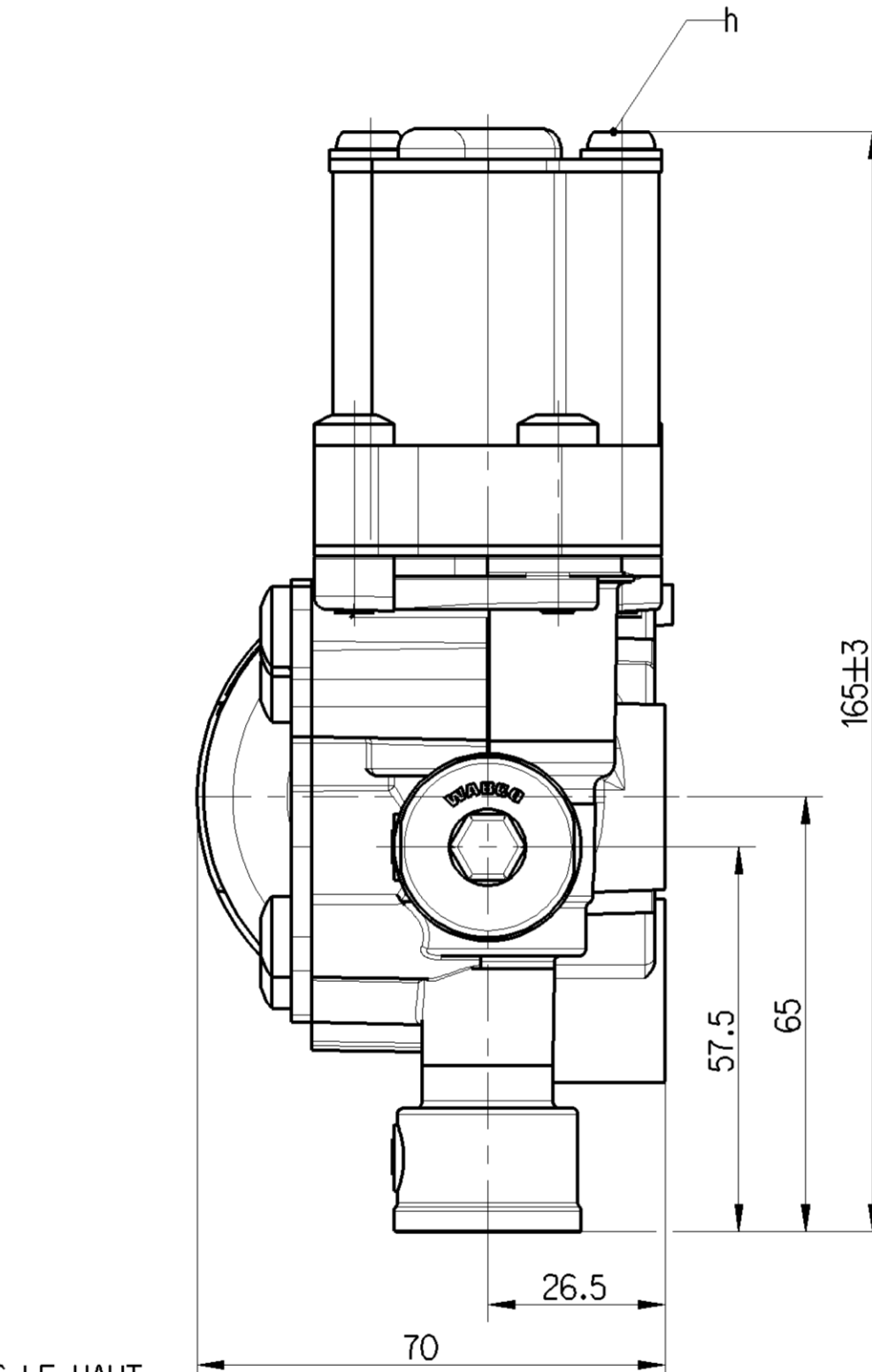

* SOCKET
 GERÄTSTECKDOSE
 PRISE DE COURANT
 PRESA DI CORRENTE

11: SUPPLY; ENERGIEZUFLOSS VOM VORRAT; ALIMENTATION;
 ALIMENTAZIONE
 21, 22, 23: DELIVERY; ENERGIEABFLUSS IN DIE ARBEITSLAUF;
 UTILISATION; MANDATA
 3: EXHAUST; ANSCHLUSS ATMOSPHAERE; ECHAPPEMENT; SCARICO
 6.1, 6.2, 6.3, 6.4: ELECTRICAL CONTROL; ELEKTRISCHER STEUERANSCHLUSS;
 COMMANDE ELETTRIQUE; COMANDO ELETRICO

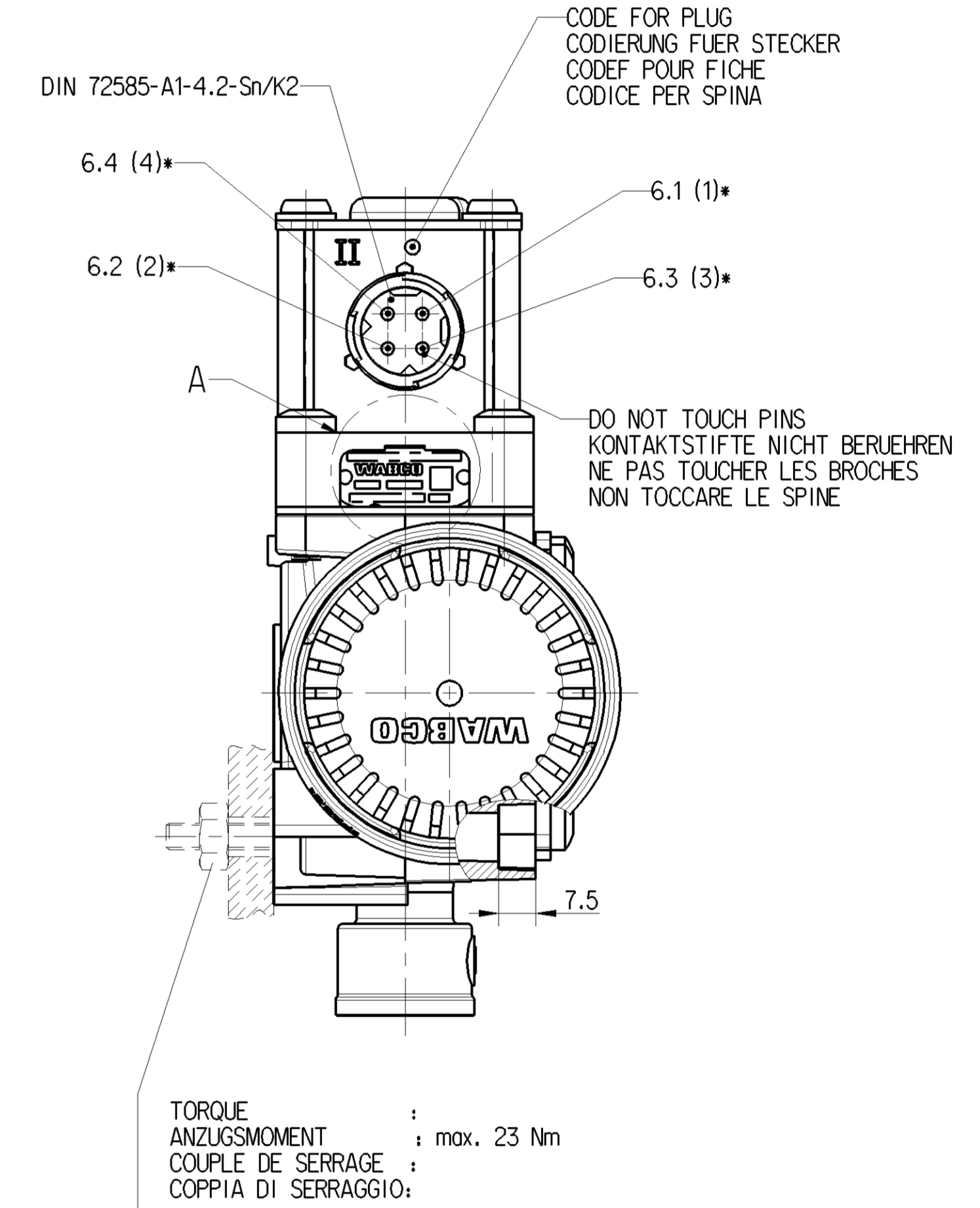
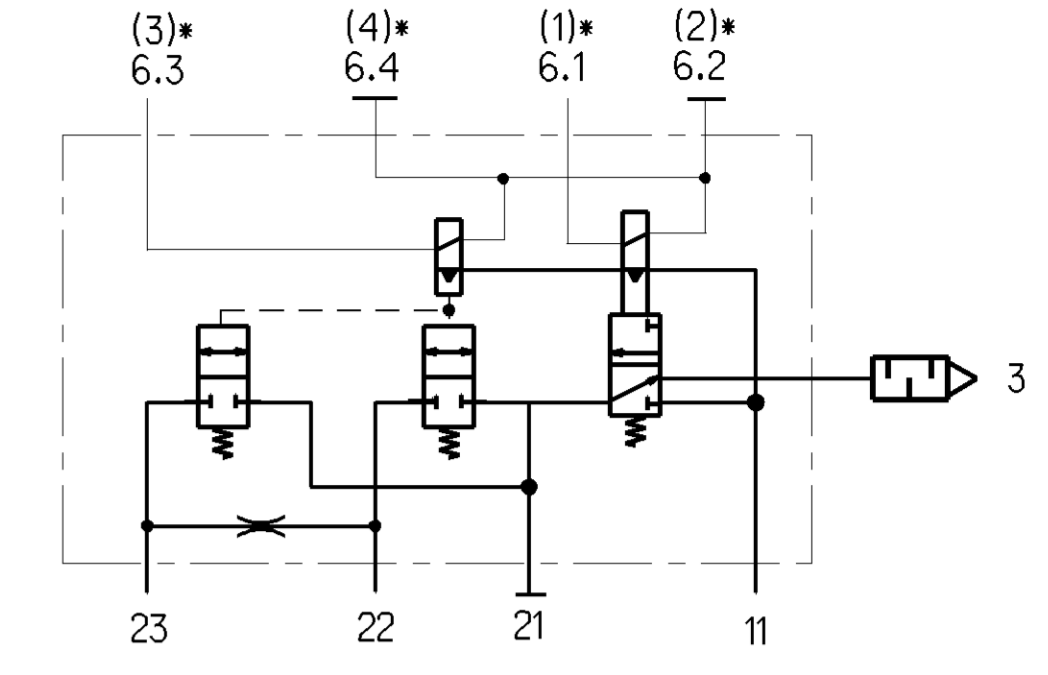
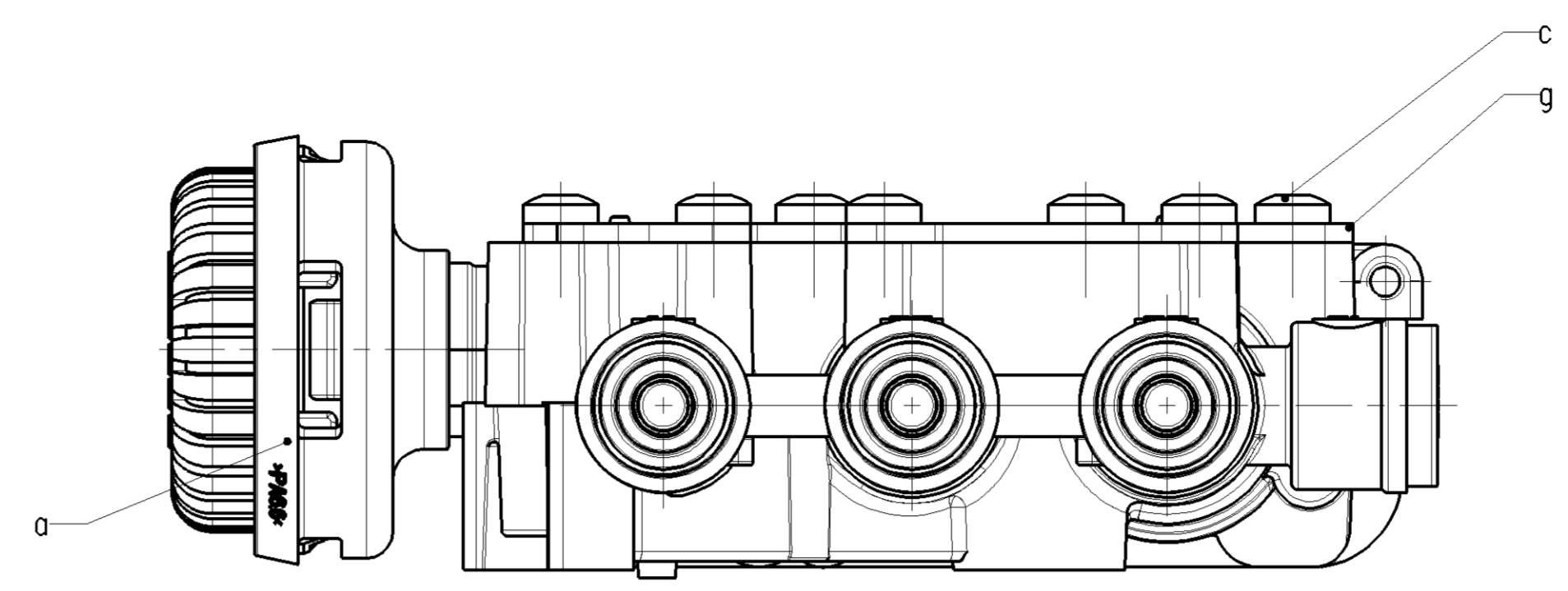

General Specification: JED-334-1, Size ISO 14405 LP		Copyright WABCO®	
Further Technical Data:		Date: 2016-12-09	Signature: Repelo
Doc. Code:	Sheet: To	Checked: Zok	Expert: Zok
General Tolerances JED-261		Range of Nominal Dimensions (± mm)	
Class	11	≤ 50	> 50 < 180
		± 0.1	± 0.15
		± 0.2	± 0.3
		± 0.3	± 0.5
		± 0.5	± 1.0
		± 1.0	± 2.0
		± 2.0	± 3.0
		± 3.0	± 5.0
		± 5.0	± 6.5
		± 3°	
Mass	2.41 kg	Scale	1:1 (2:1)
Course	2.0	Size	CAD System
Tapped Holes acc.		Material No. 472 880 030 0	
1) Tolerance Class Applied Crossmarked		ECN-No. 170972	Revision N
		Techn. Resp. 6670	Date of first issue: 005 ML 1/1
		Replacement for	

Non e permesso copiare o riprodurre questo documento, ne utilizzare o comunicare a terzi, senza permesso scritto dalla WABCO. Tutti i diritti sono riservati. Toute reproduction ou utilisation de ce document, sans autorisation écrite de la WABCO, est formellement interdite. Toute utilisation ou communication de ce document a des tiers, sans autorisation écrite de la WABCO, est formellement interdite. All rights reserved. This document is the subject of copyright.