

THERMAL RANGE OF APPLICATION:
 THERMISCHER ANWENDUNGSBEREICH: -40° ... +80° C
 GAMME D'APPLICATION THERMIQUE:
 CAMPO DI APPLICAZIONE TERMICA:

MEDIUM: AIR
 MEDIUM: LUFT
 FLUIDE: AIR
 FLUIDO: ARIA

WORKING PRESSURE:
 BETRIEBSDRUCK:
 PRESSION DE SERVICE: *
 PRESSIONE D'ESERCIZIO:

1 = SUPPLY
 VORRAT *MAX. p_e 13bar
 ALIMENTAZIONE

2 = DELIVERY PRESSURE
 AUSGESTEUERTER DRUCK
 PRESSION DELIVREE
 PRESSIONE EROGATA

4 = INLET PRESSURE
 EINGESTEUERTER DRUCK *MAX. p_e 10bar
 PRESSION D'ALIMENTATION
 PRESSIONE DI ALIMENTAZIONE

41 = CONTROL PRESSURE
 STEUERDRUCK *MAX. p_e 13bar
 42 = PRESSION DE COMMANDE
 PRESSIONE DI COMANDO

43 = TEST CONNECTION
 PRUEFANSCHLUSS *MAX. p_e 13bar
 RACCORD D'EPREUVE
 RACCORDO DI PROVA

INSTALLATION POSITION AS DRAWN
 EINBAULAGE WIE GEZEICHNET
 POSITION D'INSTALLATION SUIVANT DESSIN
 POSIZIONE DI MONTAGGIO COME DISEGNATO

TORQUE FOR CONNECTIONS:
 ANZUGSMOMENT FUER EINSCHRAUBSTUTZEN: M16×1.5: M_{max.} = 34 Nm
 COUPLE DE SERRAGE DES RACCORDS: M22×1.5: M_{max.} = 53 Nm
 COPPIA DI SERRAGGIO DEI RACCORDI:

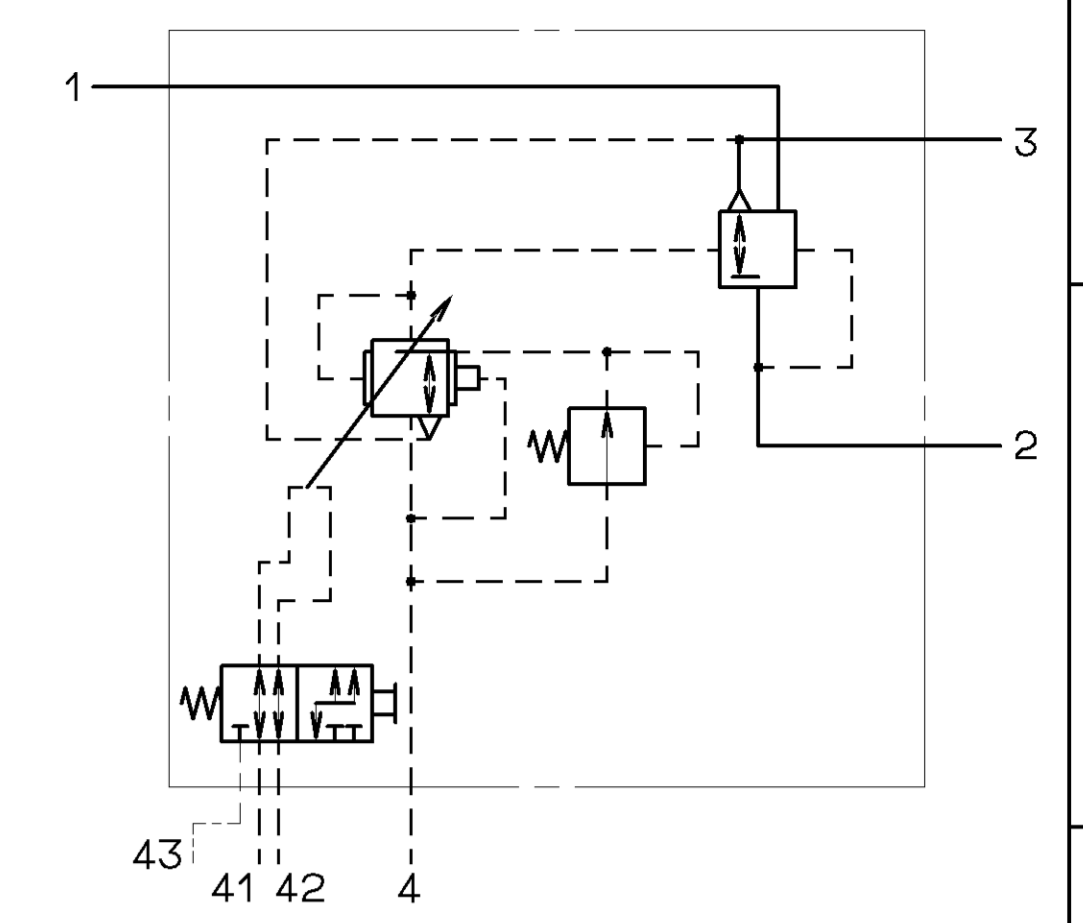

DELIVERY PRESSURE
 AUSGESTEUERTER DRUCK p₂ [bar]
 PRESSION DELIVREE
 PRESSIONE EROGATA

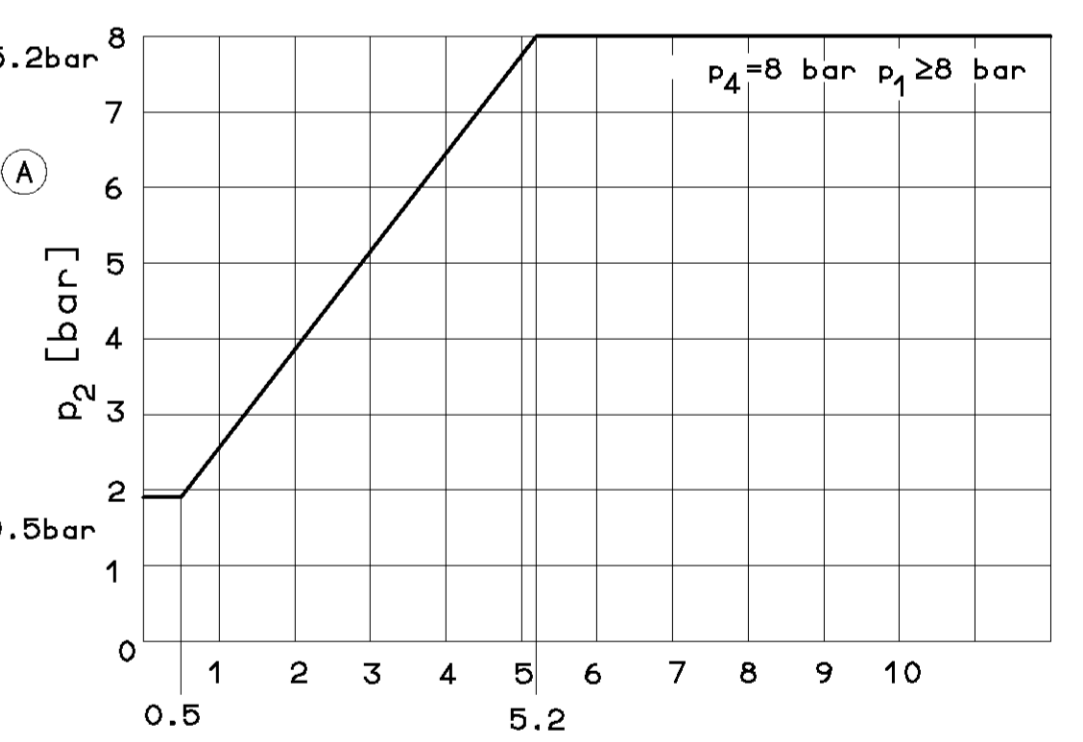
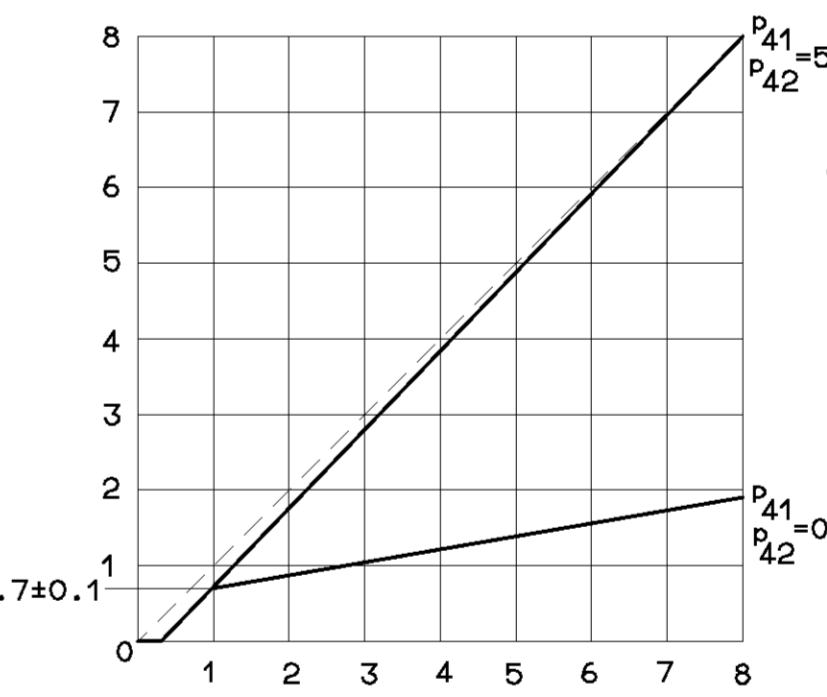

INLET PRESSURE
 EINGESTEUERTER DRUCK p₄ [bar]
 PRESSION D'ALIMENTATION
 PRESSIONE DI ALIMENTAZIONE

CONTROL PRESSURE
 STEUERDRUCK p₄₁ = p₄₂ [bar]
 PRESSION DE COMMANDE
 PRESSIONE DI COMANDO

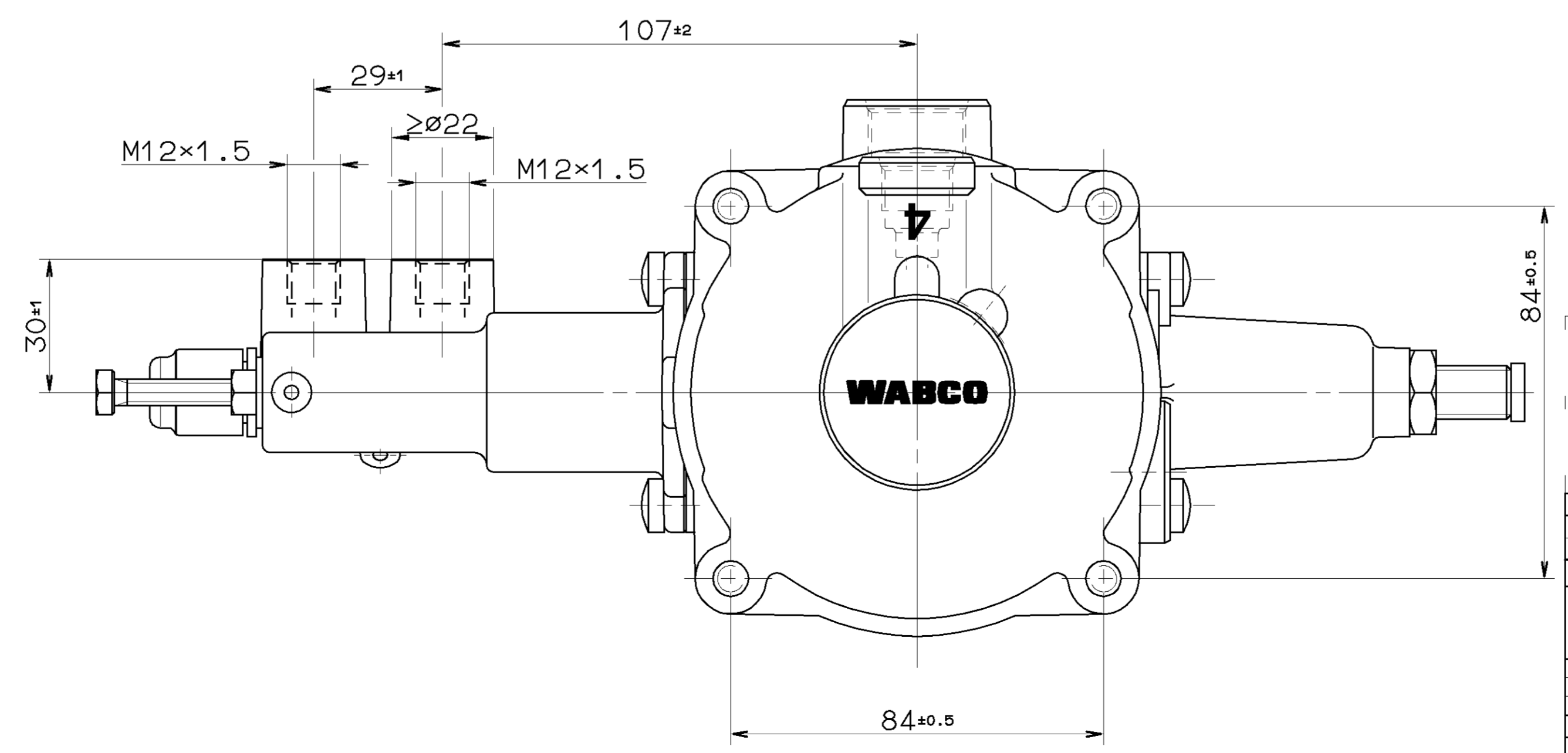

GENERAL SPECIFICATION: JED-334		CADAM-DRAWING COPYRIGHT: WABCO	
FURTHER TECHNICAL DATA:		DATE: 95-03-20	
DOC. CODE: SHEET: TO:		DRAWN: HALUKE	
GENERAL TOLERANCES		CHECKED: FAUCK	
RANGE OF NOMINAL DIMENSIONS (± mm)		STANDARDIZATION: 95-03-22	
CLASS	1)	≤50	≤180
FINE		1,0	1,5
MEDIUM		2,0	3,0
COARSE	X	2,0	3,5
TAPPED HOLES ACC. ISO 4039 / JED-162		DATE: 96-04-29	
1) TOLERANCE CLASS APPLIED CROSSHARDED		REV. DATE	
059778 1xA		96-04-29	
MASS		SCALE: 1:1	
2.1 kg		PRODUCT IDENTIFICATION NO. 475 711 120 0	
SIZE T.R.I.		DOC. CODE: 605	
A 1 140		SHEET: 1/1	
SHAPE CODE		REPLACEMENT FOR	
EXPERT CODE: 7142		PRODUCT TYPE: 010X	

TUTTE LE INFORMAZIONI DI RIPRODUZIONE DI QUESTO DOCUMENTO SONO CONSERVATE IN UN ARCHIVIO ELETTRONICO. IL CONTENUTO DI QUESTO DOCUMENTO È PROTETTO DA DIRITTI DI PROPRIETÀ INTELLETTUALE. È vietata espressamente la ristampa o l'uso non autorizzato senza permesso scritto dalla WABCO.