

# EBS3 – ELECTRONIC BRAKING SYSTEM

## SYSTEM DESCRIPTION





## 1 Table of Content

<b>1</b>	<b>List of abbreviations</b> .....	<b>5</b>
<b>2</b>	<b>General Information</b> .....	<b>6</b>
<b>3</b>	<b>Safety instructions</b> .....	<b>9</b>
<b>4</b>	<b>Introduction</b> .....	<b>11</b>
<b>5</b>	<b>Functional Description</b> .....	<b>12</b>
5.1	EBS Basic Function.....	12
5.2	Brake Management.....	12
5.2.1	<i>Deceleration Control / Braking Force Control</i> .....	12
5.2.2	<i>Brake Force Distribution</i> .....	12
5.2.3	<i>Brake Lining Wear Control</i> .....	13
5.2.4	<i>Endurance Brake Integration</i> .....	13
5.2.5	<i>Brake Assist</i> .....	13
5.2.6	<i>Hill Holder, Easy Hill Start (Roll Brake functions)</i> .....	13
5.2.7	<i>Halt Brake</i> .....	13
5.2.8	<i>Trailer Control</i> .....	14
5.2.9	<i>Hybrid Support (for Standard only)</i> .....	14
5.3	Stability Control Functions.....	14
5.3.1	<i>Drag Torque Control (DTC)</i> .....	14
5.3.2	<i>Integrated ABS Function</i> .....	15
5.3.3	<i>Integrated Automatic Traction Control (ATC)</i> .....	15
5.3.4	<i>Electronic Stability Control ESC</i> .....	15
5.4	Supporting functions.....	19
<b>6</b>	<b>System variants</b> .....	<b>20</b>
6.1	Functional overview of the system variants.....	20
6.2	EBS3 APAC System Layouts.....	21
6.3	EBS3 Standard System Layouts.....	23
<b>7</b>	<b>Components</b> .....	<b>25</b>
7.1	Brake signal transmitter.....	25
7.2	Central module ECU.....	26
7.3	Axle modulators, 4th generation.....	27
7.4	Trailer control valve.....	28
7.5	ABS Solenoid Valve.....	29
7.6	Automatic Traction Control (ATC) Solenoid Valve.....	29
7.7	Rotational Speed Sensor.....	29
7.8	ESC components.....	30
7.8.1	<i>ESC Control Module</i> .....	31
7.8.2	<i>Steering Wheel Angle Sensor</i> .....	31
<b>8</b>	<b>Fault Detection and Diagnostic Services</b> .....	<b>32</b>
8.1	Functions for Fault Detection.....	32
8.1.1	<i>Nominal Sensor Values at the Brake Signal Transmitter</i> .....	32
8.1.2	<i>Braking Pressure Sensing at the Axle Modulators and the Trailer Control Valve</i> .....	32
8.1.3	<i>Lining Wear Monitoring on Front and Rear Axle</i> .....	32
8.1.4	<i>Monitoring the EBS specific Solenoid Valves</i> .....	32
8.1.5	<i>Monitoring the braking pressure control</i> .....	32

# Table of Content

8.1.6	Monitoring the data transmission on CAN.....	33
8.2	Possible Function Shut-Downs.....	33
8.2.1	Operating without ABS Function.....	33
8.2.2	Operating without ATC Function.....	33
8.2.3	Operating without ESC Function.....	33
8.2.4	Pressure Control / Auxiliary Pressure Control.....	33
8.2.5	Back-up Operation.....	33
8.3	Fault display.....	34
8.4	ESC Fault Detection.....	34
8.5	Diagnostic Services.....	34
8.5.1	Hardware.....	35
8.5.2	Diagnostic connection.....	35
8.5.3	Diagnostic Software 246 301 221 0.....	35
<b>9</b>	<b>Workshop instructions.....</b>	<b>37</b>
9.1	Replacing Components.....	37
9.1.1	Replacing Components.....	37
9.1.2	Disposal of old parts.....	37
9.2	Test on the Roller Test Stand.....	38
9.2.1	Roller Test Stand Activation Process.....	38
9.3	Component Overview with part numbers.....	39
9.3.1	Overview of Spare Parts for EBS3 APAC.....	39
9.3.2	Overview of Spare Parts for EBS3 Standard.....	40

## **Edition 1**

Version 4 (12.2016)  
815 010 208 3 (en)

This publication is not subject to any update service.  
You will find the current version on the internet at  
<http://www.wabco.info/i/196>



## 1 List of abbreviations

ABBREVIATION	MEANING
<b>6S/6M</b>	6 Sensors / 6 Modulators
<b>ABS</b>	Anti-Lock Braking System
<b>AEBS</b>	Advanced Emergency Braking System
<b>APAC</b>	Asia Pacific
<b>ARB</b>	Automatic Roll Brake
<b>ASR</b>	Anti-Slip Regulation
<b>ATC</b>	Automatic Traction Control
<b>CAN</b>	Controller Area Network
<b>CBU</b>	Central Brake Unit
<b>CVC</b>	Central Vehicle Controller (MAN: Central Onboard Computer)
<b>DSC</b>	Differential Slip Control
<b>DTC</b>	Drag Torque Control
<b>EAS</b>	(German: Elektronischer Antriebs-Strang); electronic drive-train control
<b>EBS</b>	Electronic Braking System
<b>ECU</b>	Electronic Control Unit
<b>EoL</b>	End-of-Line
<b>EPS</b>	Electronic Power Shift or electropneumatic shift control
<b>ESC</b>	Electronic Stability Control
<b>IO</b>	Input/Output
<b>IR</b>	(German: Individual-Regelung); individual control
<b>LSV</b>	Load Sensing Valve
<b>MIR</b>	(German: Modifizierte Individual-Regelung); Modified individual control
<b>OBD</b>	On-Board Diagnostics
<b>PIN</b>	Personal Identification Number
<b>PWM</b>	Pulse Width Modulation
<b>RSC</b>	Roll Stability Control
<b>RSS</b>	Roll Stability Support
<b>SAE</b>	Society of Automotive Engineers
<b>SAS</b>	Steering-axle sensor
<b>TCV</b>	Trailer Control Valve
<b>USB</b>	Universal Serial Bus

## 2 General Information

### Copyright and trademark notice

The content, particularly technical information, descriptions and figures, corresponds to the state current at the time of printing and is subject to change without notice.

This document, including all its parts, in particular texts and figures, is protected by copyright. Use outside the statutory or contractual limits require authorisation by the copyright owner. All rights reserved.

Any brand names, even if not indicated as such, are subject to the rules of the trademark and labelling rights.

### Symbols used

 Important information, instructions and/or tips that you must always observe without fail.



Reference to information on the internet

- Action step
  - ⇒ Consequence of an action
- List

### Technical documents



- Open the WABCO INFORM online product catalogue:  
<http://inform.wabco-auto.com>
- Search for documents by entering the document number.

The WABCO online product catalogue INFORM provides you with convenient access to the complete technical documentation.

All documents are available in PDF format. Please contact your WABCO partner for printed versions.

Please note that the publications are not always available in all language versions.

DOCUMENT TITLE	DOCUMENT NUMBER
EBS3 – Elektronisches Bremssystem – Systembeschreibung	815 XX0 208 3

\*Language code XX: 01 = English, 02 = German, 03 = French, 04 = Spanish, 05 = Italian, 06 = Dutch, 07 = Swedish, 08 = Russian, 09 = Polish, 10 = Croatian, 11 = Romanian, 12 = Hungarian, 13 = Portuguese (Portugal), 14 = Turkish, 15 = Czech, 16 = Chinese, 17 = Korean, 18 = Japanese, 19 = Hebrew, 20 = Greek, 21 = Arabic, 24 = Danish, 25 = Lithuanian, 26 = Norwegian, 27 = Slovenian, 28 = Finnish, 29 = Estonian, 30 = Latvian, 31 = Bulgarian, 32 = Slovakian, 34 = Portuguese (Brazil), 35 = Macedonian, 36 = Albanian, 97 = German/English 98 = = multilingual, 99 = non-verbal

# General Information

## Structure of the WABCO product number

WABCO product numbers consist of 10 digits.

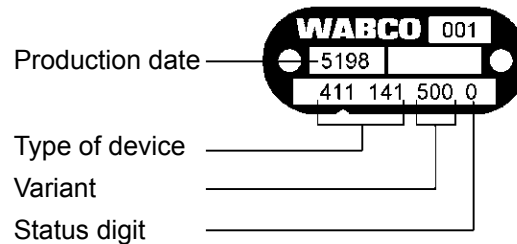

0 = New device (complete device); 1 = New device (subassembly);  
2 = Repair kit or subassembly; 4 = Component part; 7 = Replacement device;  
R = Reman

## Choose genuine WABCO parts

Genuine WABCO parts are made of high quality materials and are rigorously tested before they leave our factories. You also have the assurance that the quality of every WABCO product is supported by a powerful customer service network.

As a leading supplier to the industry, WABCO collaborates with the world's leading original equipment manufacturers, and disposes of the experience and capacitive capability required to also satisfy the most stringent production standards. The quality of every genuine WABCO part is supported by:

- Tooling made for serial production
- Regular sub-supplier audits
- Exhaustive end-of-line tests
- Quality standards < 50 PPM

**Installing replica parts can cost lives – genuine WABCO parts protect your business.**

## WABCO additional services

The package you will get with a genuine WABCO part:

- 24-month product warranty
- Overnight delivery
- Technical support from WABCO
- Professional training solutions from the WABCO Academy
- Access to diagnostics tools and support from the WABCO Service Partner network
- Straightforward claims handling
- Plus, of course, the confidence that the Original Equipment Manufacturers' rigorous quality standards are met

## WABCO Service Partner

WABCO Service Partners – the network you can rely on. You can access 2000 high quality workshops with more than 6000 specialist mechanics, all trained to WABCO's exacting standards and equipped with our most up-to-the-minute systems diagnostic and support technology.

## Your direct contact to WABCO

In addition to our online services, trained members of staff are there to help you at our WABCO Service Partners to directly answer any technical or business-related questions you may have.

Contact us if you need assistance:

- Find the right product
- Diagnosis support
- Training
- System support
- Order management



You can find your WABCO partner here:

<http://www.wabco-auto.com/en/how-to-find-us/contact/>

---



## 3 Safety instructions

### Observe all required provisions and instructions

- Read this publication carefully.
- Adhere to all instructions, information and safety information to prevent injury to persons and damage to property.
- WABCO will only guarantee the security, reliability and performance of their products and systems if all information in this publication is adhered to.
- Make sure to follow the specifications and instructions of the vehicle manufacturer.
- Comply with all operator accident prevention regulations as well as regional and national regulations.

### Make provisions for a safe work environment:

- Only trained and qualified technicians must perform work on the vehicle.
- Use personal protective equipment if required (protective goggles, respiratory protection, ear protectors, etc.).
- Pedal actuations can lead to severe injuries if persons are in the vicinity of the vehicle. Make sure that pedals cannot be actuated as follows:
  - Switch the transmission to “neutral” and actuate the parking brake.
  - Use chocks to secure the vehicle against rolling.
  - Fasten a visible note to the steering wheel indicating that work is being performed on the vehicle and that the pedals are not to be actuated.

### Avoid electrostatic charge and uncontrolled discharging (ESD)

#### **Note during construction and building the vehicle:**

- Prevent potential differences between components (e.g. axles) and the vehicle frame (chassis).
- Make sure that the resistance between metallic parts of the components and the vehicle frame is less than 10 Ohm.
- Connect moving or insulated vehicle parts, such as axles, electrically conducting with the frame.
- Prevent potential differences between the towing vehicle and the trailer.
- Make sure that an electrically conductive connection is made between metal parts in the towing vehicle and the coupled trailer via the coupling (king pin, fifth wheel, claws with pins), even without a cable being connected.
- Use electrically conductive bolted connections when fastening the ECUs to the vehicle frame.
- Run the cable within metallic casings where possible (e.g. inside the U-beam) or behind metal and grounded protective plating to minimise the influence of electro-magnetic fields.
- Avoid the use of plastic materials if they can cause electrostatic charging.

## **While carrying out repair or welding work on the vehicle:**

- Disconnect the battery if installed in the vehicle.
- Disconnect cable connections to devices and components and protect connectors and ports against contamination and humidity
- Always connect the grounding electrode directly to the metal next to the welding point when welding to prevent magnetic fields and current flow via the cable or components.
- Make sure that current is well conducted by removing paint or rust.
- Prevent heat impact on devices and cabling when welding.

## 4 Introduction

The quality of the braking system contributes substantially to the road safety of commercial vehicles. In 1996, WABCO was the first supplier to launch the series production of an Electronic Braking System (EBS) on a larger scale. As a global leader in this sector, WABCO supplies EBS for light to heavy commercial vehicles with trailers or semitrailers as well as for buses.

### The benefits of EBS

#### Braking comfort and improved safety through EBS

The driver submits his deceleration command by operating the brake. EBS then electronically transmits this command to all braking system components. Response and build-up times at the brake cylinders are reduced significantly due to electronic actuation. The ECU also facilitates a sensitive dosing of the braking system during this process. The result: A comfortable braking “feeling”, independently of the load status, and a much shorter braking distance.

The functions integrated in EBS ensure that both the vehicle’s driving stability and steerability are maintained during the braking process. The Differential Slip Control (DSC) system automatically distributes the braking forces between the front and rear axle according to the respective load status. When operated with a trailer, DSC also ensures that the tractor-trailer combination is optimally balanced. Towing vehicle and trailer respectively brake their own portion of weight in the tractor-trailer combination. The coupling force of the tractor-trailer combination is thus kept low when braking. The integrated anti slip regulation applies traction control.

#### Lining wear optimization and ease of maintenance through EBS

EBS from WABCO provides the option to continuously monitor and balance lining wear. This means that service and lining replacement times can be coordinated. All linings on the vehicle are then replaced simultaneously. The integration of endurance brakes, such as retarder and engine brake, also help to protect brake linings for longer operating times.

Extensive integrated diagnostic and monitoring functions constantly carry out self-inspections of EBS. Corresponding warnings alert the driver immediately if operational readiness is impaired. A diagnostic device or the on-board diagnostic display in the vehicle can be used to determine the causes quickly and easily. Maintenance and workshop periods can also be significantly reduced by means of the extensive test functions of the diagnostic system.

#### Significantly reduced braking distance with EBS

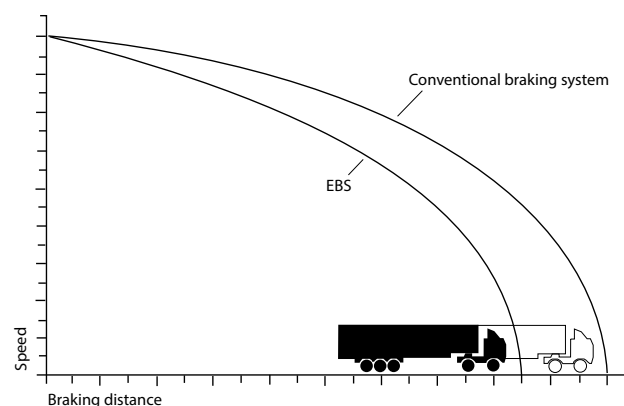

# 5 Functional Description

## 5.1 EBS Basic Function

WABCO EBS operates with electronic signals. The EBS electronic control unit controls the system through these signals and can communicate with the individual components at any time. The valves on the brake cylinders generate the required braking pressure according to the control signals.

Speed sensors installed on the wheels of the vehicle for the integrated ABS function constantly provide the EBS with up-to-date wheel speed information. Different integrated brake management functions detect any deviations from normal driving conditions and intervene in the driving process in the event of hazards. Apart from improving safety, specific functions also optimise driving comfort and lining wear.

If the electronic control system malfunctions, all valves simultaneously coordinate operation as in a conventional pneumatic system. In this case backup pressures are conducted to the brake cylinders where the pneumatic system is effectively applied, however, only with a certain delay. Since the pneumatic system does not operate with a load-proportioning valve the pneumatic backup may cause overbraking of the rear axle. What is known as a backup valve therefore blocks the effect of the pneumatic circuit on the rear axle brake cylinders while EBS functions normally.

## 5.2 Brake Management

### 5.2.1 Deceleration Control / Braking Force Control

The Deceleration Control function is used to adjust the braking pressure level to the braking command from the driver. EBS ensures that with identical pedal operations the vehicle is always braked with the same effect, regardless of the load status. If the brake linings are wet for example, EBS will increase the braking pressure until the desired deceleration is achieved. For this reason there is no need for a separate axle load sensing system for braking force control.

However, this adaptation is only carried out within certain limits. When the coefficient of friction becomes insufficient, deceleration control ceases to make any adjustments. This will bring the change in braking performance to the driver's attention.

In addition, deceleration control improves the braking hysteresis. During each brake release event the program selects the release steps in a manner that immediately changes the braking force.

### 5.2.2 Brake Force Distribution

The distribution of braking forces depends on different vehicle measurements and data. The vehicle deceleration is captured via the wheel speed changes detected by speed sensors. An evaluation of the sensor signals provides exact information on the slip on each axle and thus their braking performance. If the slip differs, one axle contributes more towards deceleration than the other. Consequently, this axle is also subject to greater wear. EBS applies differential slip control to regulate the pressures on each axle for optimum distribution of braking forces.

## 5.2.3 Brake Lining Wear Control

EBS can obtain more accurate information on the wear condition of the brakes from analogue lining wear sensors. The Brake Lining Wear Control intervenes in the distribution of braking forces during uncritical braking events if a difference in the linings of the different axles is detected. The pressure of the wheel brake with the greater wear is reduced slightly, and the pressure on the wheel brake with less worn linings is increased accordingly by up to 0.5 bar. As a result wear is balanced without the driver noticing.

! Brake lining wear sensors can be connected hardwired to the EBS (Standard variant) or via CAN (all variants).

## 5.2.4 Endurance Brake Integration

The Endurance Brake Integration function ensures the integration of available endurance brakes in all brake applications. It ensures that the endurance brakes, such as retarder and engine brake, contribute the maximum possible portion of braking work for the vehicle as a whole. The wheel brakes thus stay cool, reducing wear of brake linings, drums and discs.

Different control strategies for the Endurance Brake Integration function are available for city buses, trucks, tractors and coaches.

## 5.2.5 Brake Assist

The Brake Assist function supports the driver during full brake applications by detecting intense braking and supplying the full braking pressure into the brake cylinders - regardless of the brake pedal being fully applied or not. When the driver releases the brake pedal the brake assist system terminates the braking process.

## 5.2.6 Hill Holder, Easy Hill Start (Roll Brake functions)

EBS provides automatic roll brake functions to allow the driver to comfortably start uphill by preventing the vehicle from rolling backwards. Variants differ according to activation conditions. The function may be selected by a switch signal. The driver has to activate the function by briefly tapping the brake pedal. The system will hold the brakes as long as the activation conditions are fulfilled. If the incline is too steep for the pre-selected braking pressure, the driver may increase the holding pressure by actuating the brake pedal with increased force. After the driver has stepped off the brake pedal, the pressure will not be released before the transmission reports "ready for brake release" or after a predefined period of time has elapsed. For safety reasons the EBS monitors the required operation of at least one pedal by the driver (clutch, brake or accelerator). This is designed to prevent misuse of hill holder as a parking brake.

## 5.2.7 Halt Brake

City buses and trucks for special purposes with frequent and brief stops may be equipped with the Halt Brake function. The driver activates the Halt Brake via switch. The request "actuate the halt brake" is sent to the EBS ECU via the CAN Bus or a hardwired switch signal. This signal can also be combined with appropriate external functions such as a door control or other devices which indicate a short stop. Using the EBS modulator(s), the brake cylinders are supplied with the respective braking pressure on the front and rear axle(s). The pressure levels of the individual axles are adjustable by parameter as well as application and release gradients.

The Halt Brake is deactivated via the hardwired switch or via a CAN signal transmitted from an external device. Deactivation may also be triggered by an actuation of the accelerator pedal. The braking pressure is released for a pre-defined gradient to permit driving off.

A combination of the Halt Brake function and engine control may be selected to limit the engine torque during a stopping interval.

---

**!** For safety reasons the Halt Brake function must be connected to other vehicle operations in a manner that avoids misuse as a parking brake.

---

## 5.2.8 Trailer Control

The Trailer Control function is implemented electronically by means of the towing vehicle to trailer interface (ISO 11992) as well as pneumatically via the electro-pneumatic trailer control valve. Although the coupling force is not sensed directly, trailer control and brake force distribution in the towing vehicle are coordinated with the aim to reduce coupling forces.

If the brake management detects an insufficient deceleration of the train due to a slight incompatibility between trailer and towing vehicle, the control pressure to the trailer can be increased or decreased by a constant pressure offset (pmk).

To improve trailer brake response there is a brief pressure inshot into the trailer's control line (yellow) the start of braking. The inshot fills the control lines and prepares the brake control devices in the trailer for a quick response to the brake demand. The standard Trailer Control assumes trailer operation with a load proportioning device, either a load sensing and proportioning valve (LSV) or a dedicated trailer EBS.

The specific Trailer Control is available for markets where most trailers are operated without a load proportioning device. In this case the EBS in the towing vehicle will modify the trailer control pressure based on the detected gross combination vehicle weight.

## 5.2.9 Hybrid Support (for Standard only)

The EBS in the Standard variant can support vehicles with selected hybrid drive train layouts.

---

**!** A hybrid application is mandatory for the correct adaptation of the EBS to the hybrid drive train layout.

---

## 5.3 Stability Control Functions

### 5.3.1 Drag Torque Control (DTC)

Drag torque occurs in the drive line due to gear shifting or gas exchange. The resulting braking torques can cause the driving wheels to lock, making the vehicle unstable. The Drag Torque Control function prevents this situation. When a defined slip state is exceeded, the engine torque is increased relative to the speeds of the driving wheels, reducing the drag torque that occurs. The Drag Torque Control terminates as soon as the driving wheel values are stable again.

## 5.3.2 Integrated ABS Function

ABS is integrated in EBS. Inductive sensors measure the rotational speed of individual wheels so that any tendency to lock is detected early. The EBS ECU can reduce, stop or increase the braking pressure for the brake cylinders on the front axle accordingly via the ABS solenoid valves. The axle modulator at the rear axle (optionally at the additional axle), whose electronic control unit includes the relevant control algorithms, performs the same task.

ABS helps to prevent the wheels from locking and so improves stability when braking. On roads with extreme differences between the coefficient of friction on each side, the ABS modulated braking pressure may cause a yaw moment while braking. Because the braking force applied to the individually controlled wheels (IR) differs in this regard, it becomes extremely difficult to control the vehicle on such roads. The modified individual control (MIR) on the front axle therefore aims to reduce the braking pressure when the brake is applied independently of the absolute value of the friction coefficient. A controlled increase of braking pressure on high friction surfaces during continuous braking will finally optimise stopping the vehicle. The objective is a compromise between stability and stopping distance.

If the driving wheels indicate a tendency to lock during endurance brake application on a slippery road surface and there is a risk of an instable vehicle state, the system deactivates the endurance brake via the vehicle data bus or optionally via the endurance brake cut off relay to ensure continued driving stability.

---

**!** Wheels that are not sensed are also integrated in ABS control. Please see the respective EBS system layouts, Kapitel „6.2 EBS3 APAC System Layouts“, Seite 21

---

## 5.3.3 Integrated Automatic Traction Control (ATC)

If the driving torque on the wheels is higher than the static friction on the wheels, the increasing slip reduces traction and generates the risk of the wheels spinning. The ATC function detects the tendency to spin and reduces the driving torque via the engine control electronics. If only one wheel tends to spin, an ATC differential braking will be applied to this wheel. Engine control interventions as well as differential brake control interventions may act in parallel if appropriate for the current driving situation. At higher speeds, differential braking will be stopped to avoid overheating the brakes. A function lamp indicates that ATC control has been activated. ATC brake control will be terminated once the supply pressure drops below the defined safe pressure level.

## 5.3.4 Electronic Stability Control ESC

ESC (Electronic Stability Control) is an extension to the EBS (Electronic Braking System). While EBS is responsible for stability during driving and braking in longitudinal direction, ESC aims to increase vehicle stability during manoeuvres such as cornering and lane changes. With commercial vehicles there is a particular risk during such manoeuvres of tilting, rolling, swerving and jack-knifing due to their high centre of gravity and great weight.

Using the information from various sensors, the ESC detects such critical situations and adapts engine and braking power accordingly if necessary. This assists the driver and improves road safety.

---

**!** Additional components are required for ESC (ESC components).

---

## ESC control functions

ESC operates automatically without activation by the driver and comprises two independent control strategies:

### Directional Control (Yaw Control)

This function is activated when the vehicle loses cornering stability in critical situations, e.g. the vehicle no longer follows the driver's intended direction of driving (during sudden lane change for example). The intended driving direction is detected by means of a steering wheel angle sensor. The resulting yaw movement during cornering is measured by a yaw rate sensor integrated in the ESC module and compared to the expected yaw moment as calculated from the driver's intended direction. In case of deviations between measured and intended yaw rate, the Yaw Control uses EBS to modify the braking forces on each wheel and the engine output thereby reducing the risk of losing directional control during dynamic obstacle avoidance manoeuvres.

ESC prevents potential "jack-knifing" of a truck-trailer combination by simultaneously adjusting brake application on the trailer.

### Roll-Over Protection (RSC – Roll Stability Control)

This function is activated automatically once the vehicle's lateral acceleration reaches critical values and the vehicle is in danger of rolling over. RSC identifies the critical lateral acceleration via the corresponding sensor integrated in the ESC module. RSC uses EBS to modify the braking forces and the engine output in order to reduce roll-over risk by reducing the vehicle speed. The critical lateral acceleration depends on the detected driving situation and load conditions.

The RSC brake control applies the brakes on the towing vehicle axles as well as those on the trailer as required.

## Trailer operation

ESC works with all brake control systems in trailers with:

- Conventional braking system
- ABS
- EBS
- RSS

For some markets - mainly those without trailer ABS - a special EBS variant allows trailer pulse control for Yaw Control in order to reduce the risk of trailer wheels locking during ESC interventions due to a lack of ABS control.

! Trailer pulse control for Yaw Control is only available in the APAC system.

! The following vehicle configurations are allowed for ESC control depending on a successful application.



# Functional Description

Vehicles			Push Axle		Tag Axle	
			Liftable	steerable	liftable	steerable
Truck	4x2					
Tractor	4x2					
Bus	4x2					
Truck / Tractor	6x2-4				X	X
Truck / Tractor	6x2-4		X	X		
Truck / Tractor	6x2				X	
Truck / Tractor	6x2		X			
Bus	6x2-4					X
Truck / Tractor	6x4					
Bus	8x4					

**!** WABCO recommends combining towing vehicles with stability control only with trailers that have at least ABS control.

## Indication of ESC status to the driver via dashboard

The activation status of ESC is indicated to the driver by means of a flashing yellow warning light or dashboard symbol. The same warning light or dashboard symbol is permanently active if ESC is deactivated due to a fault or temporary deactivation.

## Switching of ESC to off-road mode by the driver

For off-road driving, operation with snow chains and other special conditions the driver may switch ESC to increased thresholds or deactivate it completely. The mode for this off-road function will be defined by the vehicle manufacturer via parameter setting. Deactivation of ESC is indicated by a permanently illuminated yellow ESC warning lamp or dashboard symbol.

## Specifics with ESC

### Modifications on the vehicle

The ESC function needs to be adapted to specific vehicle configurations, geometric dimensions, steering characteristics and other specific vehicle data. This adaptation is implemented by the vehicle manufacturer as part of the End of Line parameter setting.

Any modifications to the vehicle subsequent to the final adaptation need to be authorised by the vehicle manufacturer and generally require a new parameter setting:

- Changes and modifications on the steering mechanism (steering ratio, steering levers, left-hand/right-hand steering, limitation on steering angle)
- Total gross vehicle weight
- Axle design and suspension (different springs, change from steel to air suspension,...)
- Additional axles, changes from rigid to steerable and/or liftable axle
- Changes to the wheel base (shorter or longer)

### Repair or replacement of ESC relevant components

Following repair works and replacement of parts (identical part with same specification) require a recalibration of the steering wheel angle sensor:

- Steering columns and steering gear
- Steering wheel angle sensor
- Front axle incl. steering levers

The calibration has to be followed by an ESC initialisation.

This ESC initialisation is also required if following components have been replaced by identical other parts (same specifications):

- ESC module
- Central ECU

The required services for calibration and initialization will be provided by the respective System Diagnosis.

### Tractor Mixed Use

Semitrailer tractors and towing trucks with full trailers require different ESC control strategies. This will be specified by the vehicle manufacturer's End of Line parameter setting. In the case that semitrailer tractors are also equipped to tow full trailers the respective "tractor mixed use" parameter has to be set accordingly.

---

**!** It is not allowed to tow full trailers with semitrailer tractor without this parameter adaptation.

---

## 5.4 Supporting functions

### Rotational speed sensing and tire size adjustment

Wheel speed sensing corresponds to the sensing function known from ABS. Nominal tire sizes have to be set by parameter and need to be adjusted when the tire sizes are changed. An automatic tire size adjustment function compensates differences between actual and nominal tire sizes and thus the rolling circumferences between the axles. If unacceptable wheel tire combinations are used, this is detected as a fault. If a speed signal from the calibrated speedometer is available on CAN, the tire size adjustment allows tire size changes within an extended range without needing to change the parameters in EBS; the calibration of the speedometer following a tire replacement is all that is required.

## 6 System variants

The following system variants of the EBS3 are available:

- APAC
- Standard

### 6.1 Functional overview of the system variants

Both systems include the following basic functions:

- 4S4M systems support

#### **Brake Control**

- Brake Force Distribution
- Brake Blending
- Deceleration Control
- Coupling Force Control
- Halt Brake
- Hill Start Aid / Hill Holder

#### **Stability Control**

- Anti-Lock Braking Function
- Traction Control
- Electronic Stability Control with Directional Control (Yaw Control) and Roll Stability Control
- Engine / Drag Torque Control

#### **Performance Monitoring**

- Lining Wear Control
- Brake Temperature Monitoring
- Total Brake Performance Monitoring

**In addition to the basic functions, the APAC system includes:**

- Specific adaptations for the Asian market
- Easy Hill Start Aid

**In addition to the basic functions, the Standard system includes:**

- Optional 6S/6M system support
- Brake Control:  
Hybrid Support
- All Wheel Drive
- Lining Wear Sensor Input
- More flexible IO configuration
- Automatic differential lock deactivation
- Low Pressure Detection

## 6.2 EBS3 APAC System Layouts

### System layout EBS3 Standard / System configuration 4S/4M – without Lining Wear Sensor

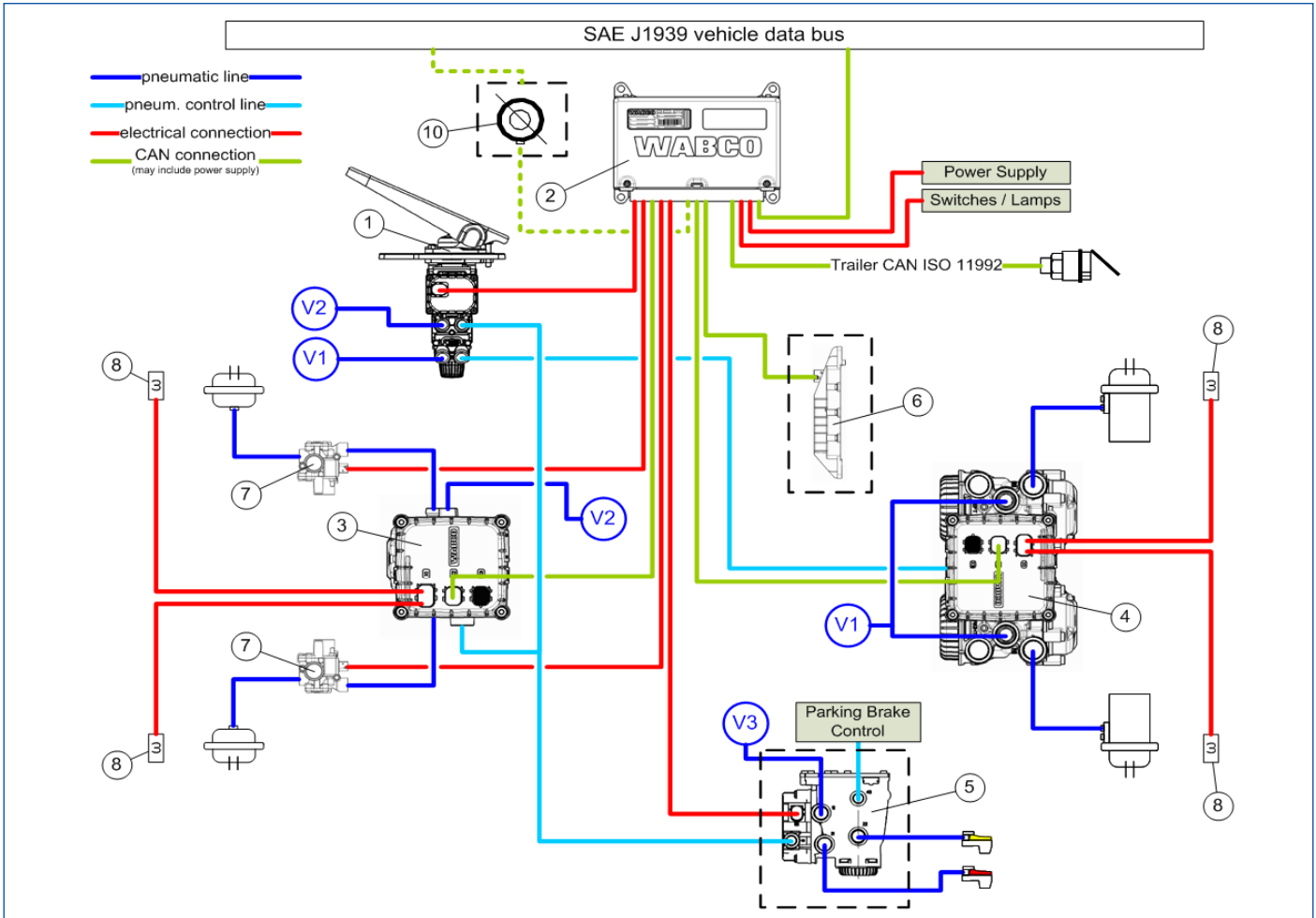

The EBS configuration 4S/4M consists of the following parts supplied by WABCO:

Item	Designation
1	Brake signal transmitter with 2 integrated sensors and 1 reversing switch
2	Central electronic control unit (central module)
3	Axle modulator 1M with integrated ECU for front (steering) axle
4	Axle modulator 2M with integrated ECU for rear (drive) axle
5	Electro-pneumatic trailer control valve (optional)
6	ESC module (optional)
7	Two ABS modulator valves (ABS solenoid control valve) for front axle
8	Two each wheel speed sensors at front and rear axle
9	Steering-axle sensor (SAS, optional)

The use of parts from other suppliers must be authorised by WABCO.

The EBS 4S/4M system can be extended by an additional ESC module and steering angle sensor for ESC capability.

# System variants

## System layout EBS3 Standard / System type 4S/4M – without Lining Wear Sensor – 6x2 (1 tag / 1 driven axle)

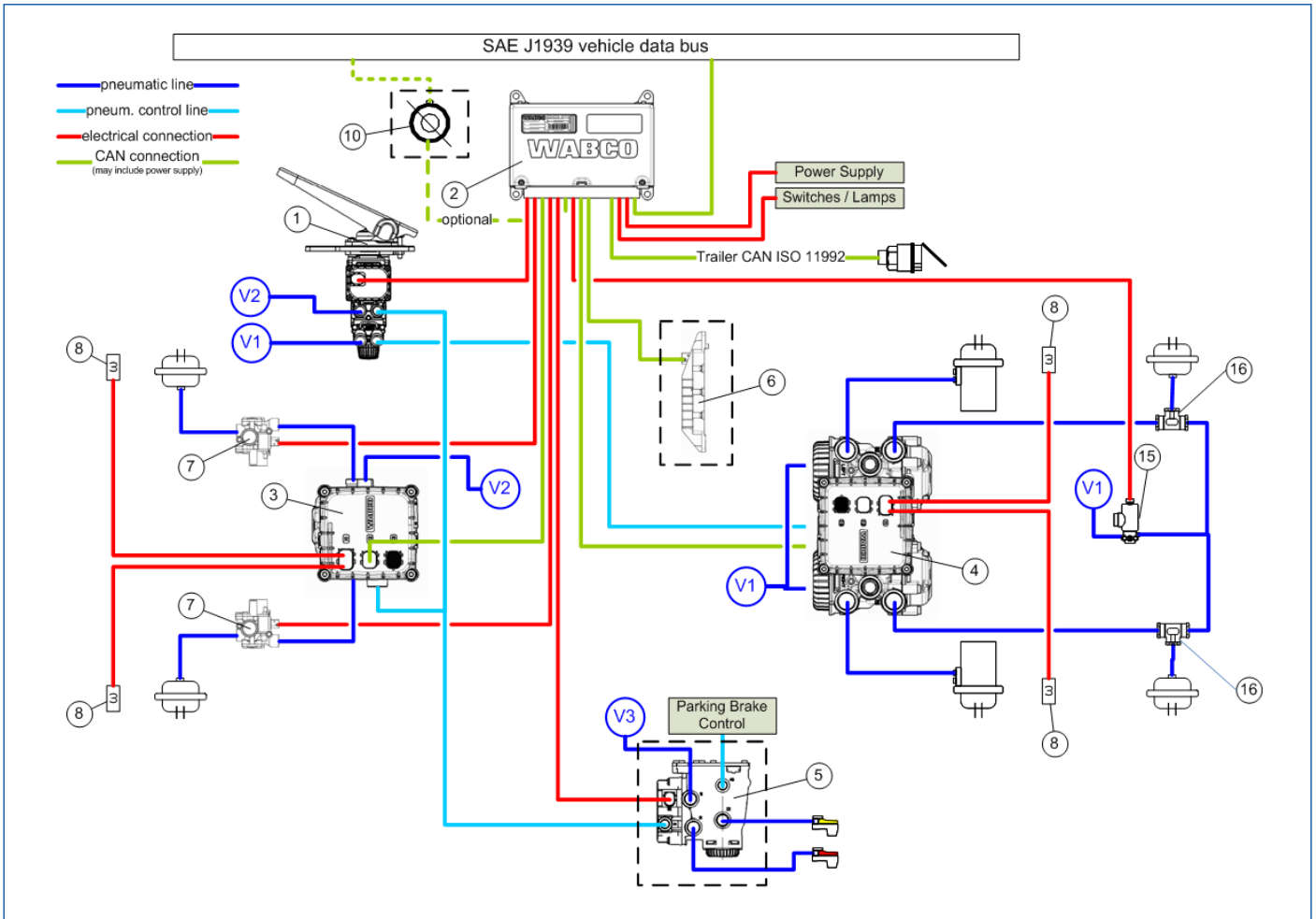

The 4S/4M system can be adapted to different vehicle types as shown in the example for a 6x2 with tag axle and one driven rear axle. In this example an additional ATC solenoid valve (15) is used.

## 6.3 EBS3 Standard System Layouts

### System layout EBS3 / System configuration 4S/4M – with Lining Wear Sensor

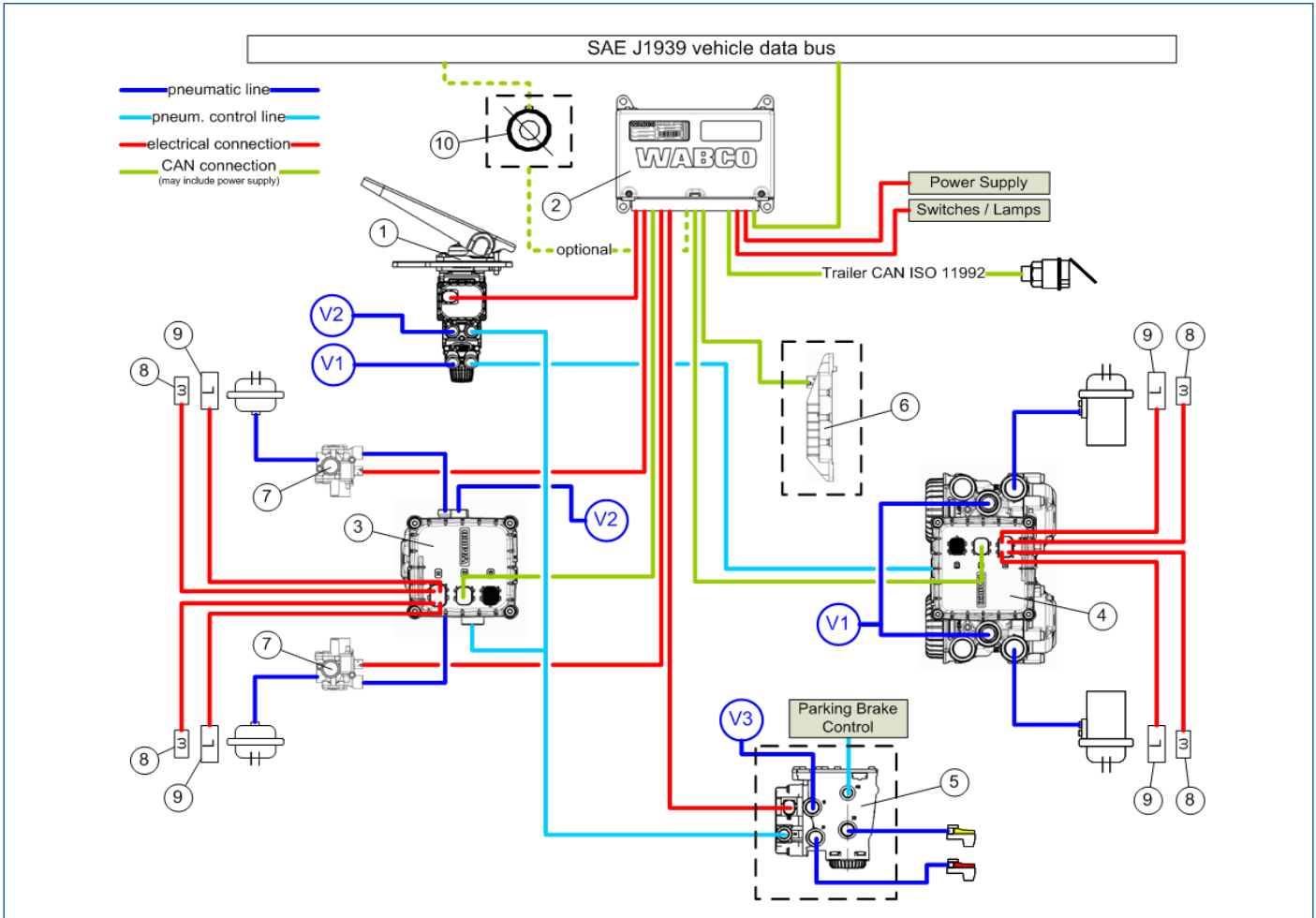

The EBS configuration 4S/4M system consists of following parts supplied by WABCO:

Item	Designation
1	Brake signal transmitter with 2 integrated sensors and 1 reversing switch
2	Central electronic-control-unit (central module)
3	Axle modulator 1M with integrated ECU for front (steering) axle
4	Axle modulator 2M with integrated ECU for rear (drive) axle
5	Electro pneumatic trailer control valve (optional)
6	ESC-module (optional)
7	Two ABS modulator valves (ABS solenoid control valve) for front axle
8	Two each wheel speed sensors at front and rear axle
9	Steering-axle sensor (SAS, optional)

The use of parts from other suppliers shall be agreed by WABCO.

The EBS 4S/4M shall be extendable with additional ESC module and steering angle sensor in order to perform ESC.

# System variants

## System layout EBS3 Standard / System configuration 6S/6M

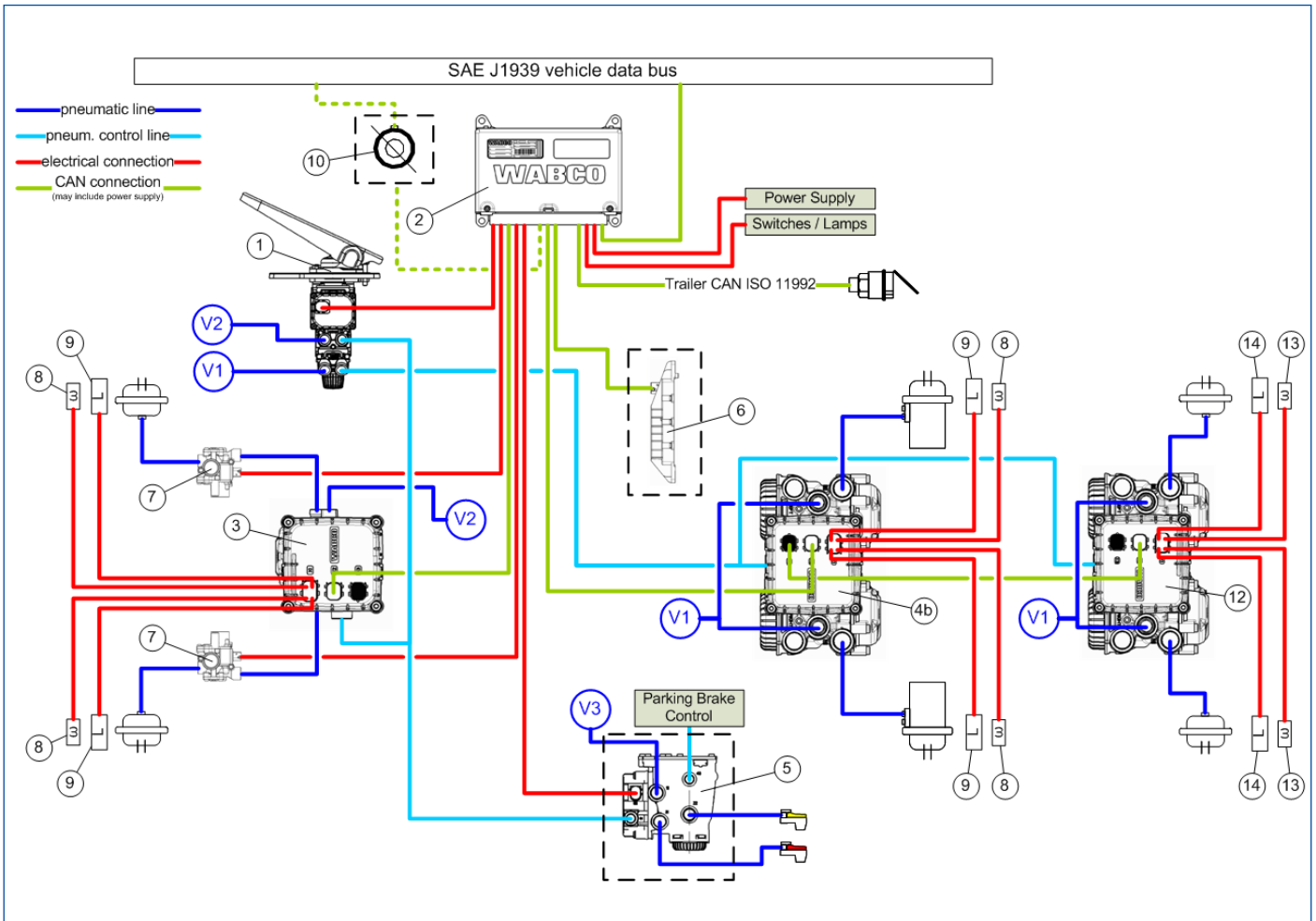

The EBS configuration 6S/6M consists – in addition to the components for the configuration 4S/4M listed above – of following parts supplied by WABCO:

Item	Designation
11	Axle modulator 2M with integrated ECU for rear (drive) axle – gateway variant
12	Axle modulator 2M with integrated ECU for additional tag or pusher axle
13	Two wheel speed sensors at additional axle
14	Two lining wear sensors at additional axle (optional)



## 7 Components

This component description details the properties of basic components.



Further details can be accessed by entering the product number in the INFORM product database on the Internet at <http://www.wabco-auto.com>.

For information on order numbers and interchangeability of the components, Kapitel „9.3 Component Overview with part numbers“, Seite 39.

### 7.1 Brake signal transmitter

480 003 XXX 0 (possible with pedal assembly)



Mode of operation

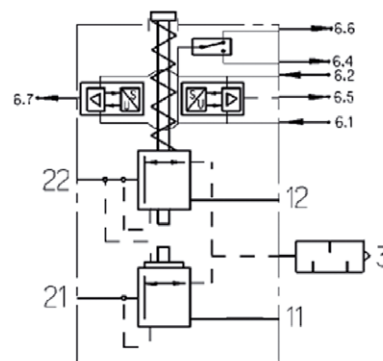

The brake signal transmitter receives the delay request from the driver via the brake pedal and generates the electrical signals and pneumatic pressures for charging and venting the actuators.

The device has a dual-circuit electronic and a dual-circuit pneumatic structure. When actuating the brake pedal, initially two electrical switching signals are generated. These are connected to the electronic control unit and are used for the operational execution and monitoring of the braking procedure. The switching operation is carried out mechanically. The pedal stroke is recorded by two sensors and is emitted from the Brake Signal Transmitter as a Pulse Width Modulated signal (PWM).

The pneumatic part of the brake signal transmitter consists of a slide-operated two-circuit foot brake valve. After the switch and first linear transducer signals have been transferred, the pneumatic back-up pressures in circuits 1 and 2 are controlled. For a better brake force distribution during back-up mode the output pressure  $p_{21}$  is reduced relative to  $p_{22}$  at a ratio of 1:1,5. In case of a malfunction in one of the electronic circuits, the other electronic circuit and the two pneumatic circuits remain functional.

## 7.2 Central module ECU

446 135 XXX 0



The central module controls and monitors the electronically controlled braking system. It determines the vehicle's nominal deceleration from the signals received by the brake signal transmitter and external deceleration demands (e.g. AEBS). The set deceleration and wheel speed measured through the speed sensors create a collective input signal for the electro-pneumatic control system. The central module calculates the nominal pressure value for the front axle, the rear axle, in the 6S6M system, the additional axle and for the trailer control valve from the input signal.

The central module actuates and monitors the electronically controlled braking system. The following list gives an overview of the actuator and control functions:

Reading the set point for deceleration from the brake signal transmitter.

- Calculating the pressure set-points for the brakes.
- Integration of the halt brakes.
- ABS function
- ATC function
- ESC control
- System diagnosis
- Data communication to the axle modulators
- Communication to the ESC Module and the Steering Angle Sensor.
- Communication to other systems in the vehicle via the SAE J1939 vehicle bus. The vehicle bus controls, among other things, the engine control function, the halt brakes and the visualisation of operating conditions and warnings for the driver. Also requests for deceleration from cruise control are received on the vehicle bus.
- Control of electronically controlled trailers via ISO 11992 interface. The central module communicates with other systems on the towing vehicle such as the motor control or the retarder using a vehicle data bus.
- Gateway from ISO 11992 trailer interface to vehicle bus.

The central module is activated via terminal pin 15 or the brake signal transmitter and switches the power supplies for the modulators, the steering angle sensor and the vehicle stability control.

Terminal pin 30 supplies the EBS with battery voltage in two circuits.

## 7.3 Axle modulators, 4th generation

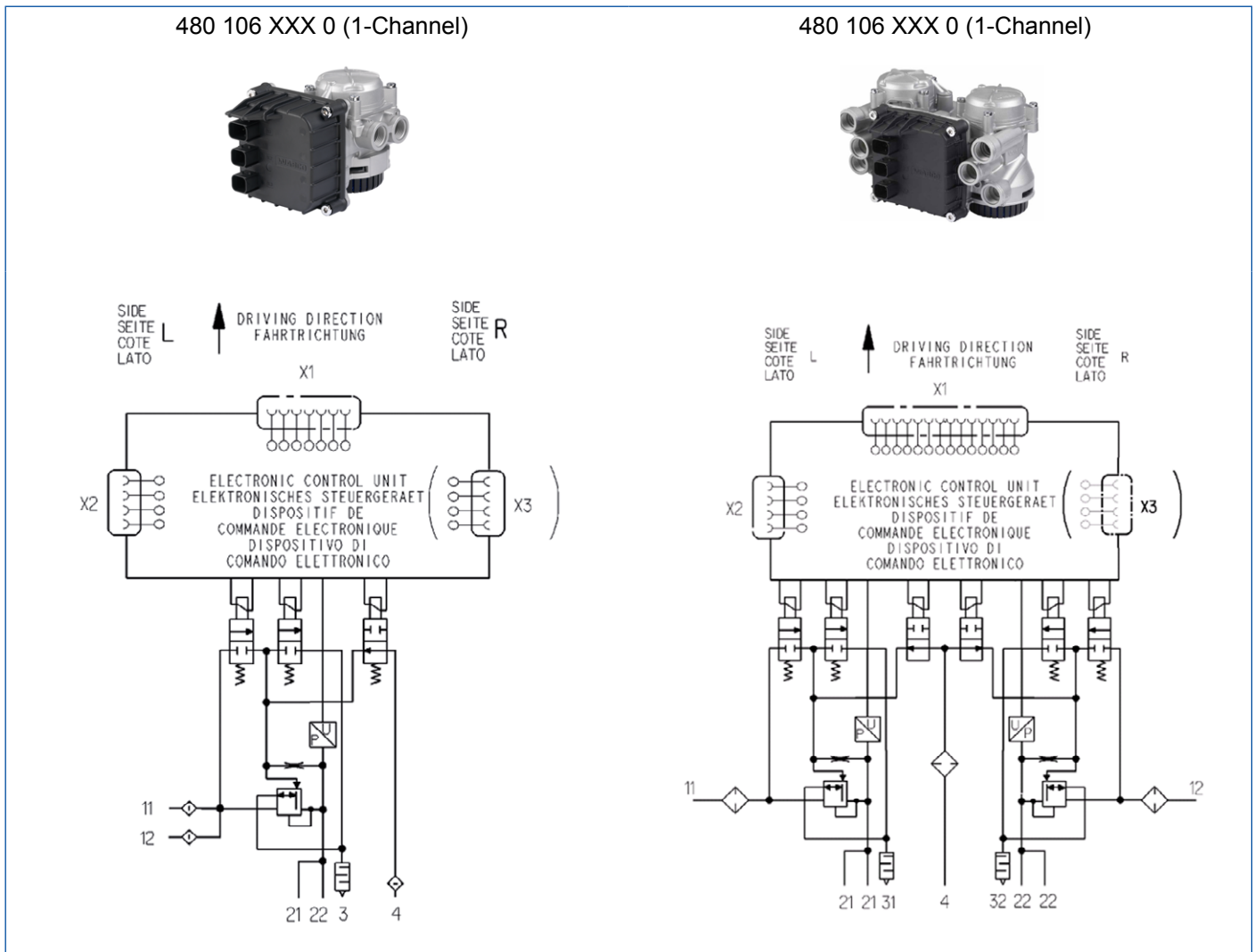

Since the introduction of EBS into serial production in 1996 WABCO has developed four axle modulator generations.

The new design of a 1-channel version is intended for front and rear axles. In a 2-channel version, the axle modulator is used on rear axles. The axle modulator in different variants controls the brake actuator pressure on both sides of a single or dual axle; on the front axle as a 1-channel modulator version, on the rear axles as 1- or 2- channel modulator version. It contains one or two independent pneumatic pressure control channels (two channels for right and left truck orientation), each containing a pulsed inlet and outlet pilot valve, plus one braking pressure sensor, sharing one electronic control unit.

The axle modulator records the wheel speeds using speed sensors, evaluates and sends them via the CAN bus to the central module, which subsequently calculates the nominal pressure. ABS control is applied directly by the rear axle modulators. In the event of wheels locking or spinning, the rear axle modulator modifies the nominal pressure. The front axle modulator, actuated by the ABS solenoid valves installed to control the pressure on the front axle brake actuators, supports the ABS function on the front axle.

Provision is made on specific device variants for connecting two sensors to detect brake lining wear.

All axle modulators are equipped with an additional connection for the backup pressure control circuit of the brake signal transmitter. 6S/5M or 6S/6M systems can be designed with three axle modulators for controlling the individual wheels.

The communication on the CAN system brake bus runs on 500 kbit/s and uses a physical layer according to ISO 11898. The internal terminating resistor depends on the device variant.

## 7.4 Trailer control valve

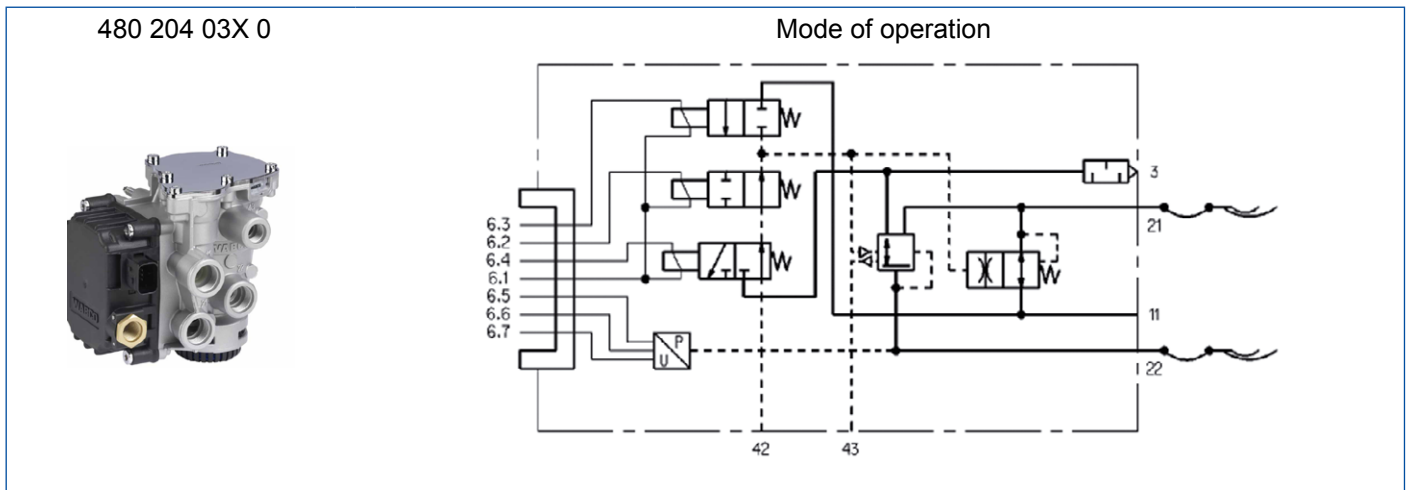

The Trailer Control Valve (TCV) controls the pressure at the coupling heads - and thus the braking behaviour of the trailer - by means of an electro-pneumatic circuit and a pneumatic circuit. It receives the nominal pressure values from the Electronic Control Unit.

The TCV consists of a relay valve, a pilot unit containing a 2/2 inlet valve and a 2/2 outlet valve, a 3/2 backup valve, a breakaway valve and a pressure sensor. The electrical control and monitoring is performed by the central electronic control unit.

The two pilot solenoid valves convert the control current predefined by the electronic control unit into a control pressure for the relay valve. The TCV output pressure (port 22) is proportional to this control pressure. Pneumatic control of the relay valve is affected by the backup pressure of the brake signal transmitter and the output pressure of the hand-brake valve.

Port 42 is designed for backup pressure. In the case of electro-pneumatic control (normal state), the backup pressure is retained by the 3/2 backup solenoid valve. Without electronic control, the backup pressure will not be retained.

Port 43 is connected to the hand brake valve. When the pressure applied at port 43 is reduced, the pressure in the trailer brake line (port 22) will increase, irrespective of the electro-pneumatic and backup pressure. When port 43 is completely exhausted, the output pressure delivered at port 22 amounts to a minimum of 7 bar (at a supply pressure of 8,5 bar).

The sensor monitors the output pressure delivered by the TCV (port 22) and returns the signal to the electronic control unit. If considerable pressure loss is detected at port 22 (e.g. because the trailer brake line breaks away) during full braking, the breakaway valve throttles the supply of the relay valve part in the TCV via port 11. This causes a pressure drop at port 21 (trailer supply line). Forced trailer braking is effected by rerouting the trailer brake valve within the trailer.

**!** The trailer control valve does not allow manual predominance setting as this is handled by the parameter setting in the central electronic control unit.

## 7.5 ABS Solenoid Valve

472 195 XXX 0

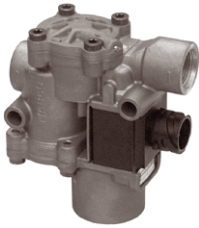

Mode of operation

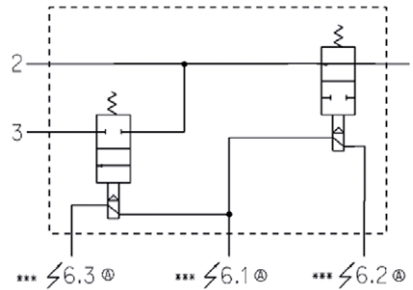

The ABS solenoid valves are mounted onto the front axle. The valves are open during normal driving conditions and control the pressure applied by the proportional solenoid valve to the brake cylinder. When ABS is activated, the inlet valve closes and prevents further pressure supply to the brake cylinder. If the tires still lock, pressure is released through an additional outlet in the valve.

## 7.6 Automatic Traction Control (ATC) Solenoid Valve

472 17X XXX 0



Mode of operation

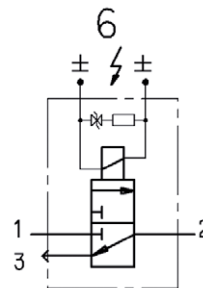

For ATC braking pressure control in 6x2 vehicles with 4S/4M system, the braking pressure to the tag axle may be switched off via a separate ATC cut-off valve (3/2 Solenoid valve). This valve is controlled by the Central Module. Other layouts with select low control (without ATC cut off valve) of the additional axle are also possible.

## 7.7 Rotational Speed Sensor

441 032 XXX 0



The Rotational Speed Sensor permanently calculates the actual wheel speed via a pole wheel and transfers the data to the EBS, which then calculates the actual speed by means of the reference values. If there are any deviations from the normal condition, the system intervenes in the regulation of the brake and motor controls.

## 7.8 ESC components

ESC should be integrated when installing EBS, as retrofitting will require a calibration and a new parameter setting identical to the one applied when the vehicle is produced. You will find an overview of the ESC components in the system layout, Kapitel „6 System variants“, Seite 20.

For the ESC functionality an ESC module and a steering-axle sensor (SAS) must be connected to the system CAN bus. The SAS can optionally be connected to the vehicle CAN bus as well.

The overall sensing technology in the ESC system comprises:

- ABS sensors - already required for EBS - that measure the wheel speed
- A steering wheel angle sensor that measures the steering wheel's angle of rotation
- The EBS ECU, which evaluates the signals from the steering wheel angle sensors and also takes control of various ESC functions for fault detection and diagnostic services
- The ESC module into which the lateral acceleration and yaw rate sensors are integrated (includes sensor signals evaluation and comparison with nominal values)

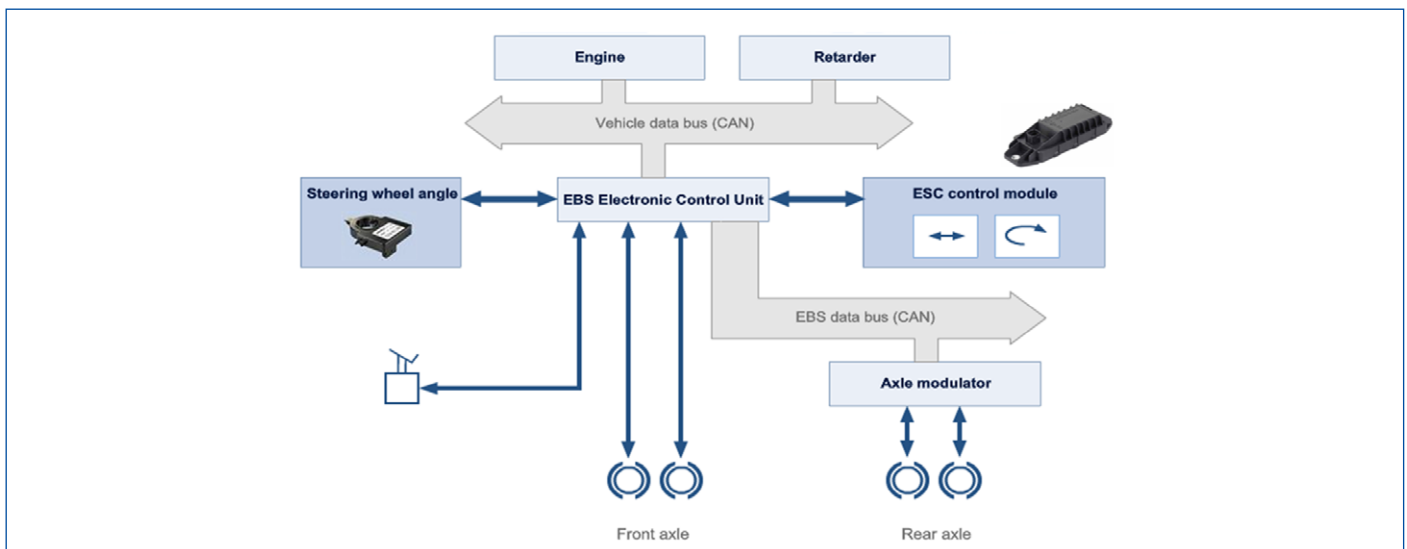

## 7.8.1 ESC Control Module

446 065 XXX 0



The ESC module contains a yaw rate sensor to measure the vehicle's rotary motion about its vertical axis as well as an acceleration sensor measuring the lateral acceleration and they provide this information on the CAN data bus.

**!** The ESC module is always mounted near to the vehicle's center of gravity to ensure correct measurement by the yaw rate and lateral acceleration sensors.

## 7.8.2 Steering Wheel Angle Sensor

441 120 XXX 0



The steering wheel angle sensor is installed at the steering column of the vehicle and provides a measuring value for the absolute angle (position) of the steering wheel. This includes the capability identifying the steering wheel zero position (center position) by means of sensor calibration.

The EBS could optionally use selected SAS from other suppliers.

## 8 Fault Detection and Diagnostic Services

### 8.1 Functions for Fault Detection

Various functions for fault detection are integrated into the EBS self-test function. These are intended to minimise the effect of system malfunctions and inform the driver of functional restrictions. Following input data and connected devices are monitored by the EBS self-test:

#### 8.1.1 Nominal Sensor Values at the Brake Signal Transmitter

The brake signal transmitter provides two sensor and two switch signals. The (pulse-width modulated) sensor signals are checked for validity and plausibility relative to other signals. Additionally the signals are checked for mutual deviations and an automatic offset adaptation is implemented when the brake signal transmitter is not applied. The digital switching signals are checked for switching states and plausibility relative to sensor signals.

#### 8.1.2 Braking Pressure Sensing at the Axle Modulators and the Trailer Control Valve

The analogue pressure sensor's signals in the pressure control circuits are checked for validity and plausibility relative to other signals. Depending on the operation conditions, a deviation between measured and demanded pressure values will also lead to a fault detection.

---

**!** The wiring for the pressure sensors in the axle modulators cannot be accessed from the outside since it is an internal axle modulator wiring.

---

#### 8.1.3 Lining Wear Monitoring on Front and Rear Axle

The analogue signals of the lining wear sensors are checked to verify whether they correspond to the admissible values.

---

**!** This feature is only included in the EBS3 Standard system as the EBS3 APAC system does not support hardwired lining wear sensors.

---

#### 8.1.4 Monitoring the EBS specific Solenoid Valves

The solenoids in the EBS modulators and valves are monitored for correct control condition and plausibility relative to other signals. The solenoid cables for valves inside the modulators are not accessible from the outside.

#### 8.1.5 Monitoring the braking pressure control

The electronically controlled braking pressure and pneumatic back-up pressure are monitored by the following functions:

- A test is carried out to check if a minimum braking pressure with a defined magnetic flow is present at the trailer control valve.
- For normal braking processes the measured braking pressure on the left and right sides of the axles must be identical within certain permissible tolerances. If the braking pressure deviation exceeds the permissible value, a fault is reported.



- In certain situations when the vehicle is stationary and the parking brake is applied, the electronic control of the braking pressure on front and rear axle will be suppressed. If the driver now actuates the brake pedal, the brakes on front and rear axle are controlled via pneumatic backup only. If the front axle braking pressure exceeds a certain value, the rear axle must have a specified minimum pressure. If this is not the case, a fault is reported. The same applies to an optionally attached additional axle.

## 8.1.6 Monitoring the data transmission on CAN

EBS monitors the data transmission on CAN:

- between EBS control units such as the central module and axle modulators on the CAN system bus
- between EBS and other vehicle control units on the CAN vehicle data bus SAE J1939
- between towing vehicle and an electronically controlled trailer brake system

If the communication is not possible or is interrupted, a fault is reported.

## 8.2 Possible Function Shut-Downs

Depending on the fault detected, certain functions in the EBS may be deactivated to avoid further negative effects of a fault. Functions which are not impaired by the fault are continued.

### 8.2.1 Operating without ABS Function

Depending on the type of fault, the ABS function may be deactivated on a single axle or on the complete vehicle.

### 8.2.2 Operating without ATC Function

The automatic traction control may be switched off completely or partially. Partial deactivation means that either engine control or differential brake control will be deactivated.

### 8.2.3 Operating without ESC Function

For further information, Kapitel „8.4 ESC Fault Detection“, Seite 34

### 8.2.4 Pressure Control / Auxiliary Pressure Control

Normally, the braking pressure control function requires braking pressure sensor signals. If this signal is no longer available, electrically controlled braking pressure can be generated using auxiliary means. In this case the accuracy of pressure control is limited as compared to error-free pressure control.

### 8.2.5 Back-up Operation

If the electrical pressure control becomes impossible for a single axle or the complete vehicle, electrical pressure control is replaced by the pneumatic back-up pressure.

## 8.3 Fault display

Detected faults are transmitted by the EBS central module to the instrument panel display via the CAN vehicle data bus SAE J1939 and displayed accordingly.

Faults can also be reported via hardwired red and yellow warning lights. A separate hardwired stability control light then indicates to the driver the ESC and ATC state.

RED WARNING LAMP	YELLOW WARNING LAMP
EBS at least partly deactivated with deceleration performance reduced below legal thresholds	Limited EBS control performance but legal requirements for deceleration performance still fulfilled

## 8.4 ESC Fault Detection

Faults in the ESC do not affect the main braking system. If a fault occurs in ESC, the ESC function will be deactivated partly or completely but other EBS functions remain active. Exclusive ESC faults will be displayed on a separate warning lamp or fault display. Of course faults that affect both ESC and EBS functions are also possible.



The driver is informed of faults in the ESC by a warning lamp.

## 8.5 Diagnostic Services



The off-board diagnostic device may actuate vehicle components. This may cause the vehicle to move. Therefore you need to make sure that this movement does not represent a hazard before you start diagnostics.

The diagnostic services are controlled by an off-board diagnostic device connected to the EBS ECU via CAN vehicle data bus. The WABCO diagnostic software needs to be installed on a PC or laptop connected to EBS via a diagnostic interface. This software is available in different languages for different EBS systems.

The diagnostic software and current measuring data can be obtained using the diagnostic program. An EBS failure will be described when malfunctions occur. Activation and control of EBS components and functions are in this case only used for a system start-up check after first system installation or after major repair and replacement work. WABCO PC diagnosis software offers prepared and predefined command sequences for the necessary startup checks.

The diagnostic software may be used by any user, but for parameter changes and any calibration procedures an authorisation is required (PIN). You can obtain this PIN through relevant training at the WABCO Academy.



More information on WABCO Academy training courses can be found on the Internet at <http://www.wabco-academy.com>.

## 8.5.1 Hardware



### PC / Laptop

WABCO offers an impact- and contamination-resistant laptop suitable for use in the workshop. This “Toughbook” already has the diagnostic software installed and can be obtained from WABCO.

The diagnostic software will run on all standard PCs with Microsoft Windows XP operating system or higher.

There are no other special hardware requirements. The PC requires a free USB connector or a free serial connector (COM interface, 9-pin) to connect the diagnostic interface.

### Diagnostic Interface Set

To set up the diagnosis, the WABCO Diagnostic Interface Set (order number 446 301 030 0 - USB connection) is required. The set contains the diagnostic interface and a USB connecting cable to the PC or laptop.

The old diagnostic interfaces with serial connection (446 301 021 0) and USB connection (446 301 022 0) can still be used.

## 8.5.2 Diagnostic connection

A special diagnostic cable is required for the connection between the computer, the diagnostic interface and the vehicle. Most common is a connection via the OBD (on board diagnosis) plug. For this purpose WABCO offers the OBD multi-switch cable (446 300 003 0).

You can find more details about cables and connecting materials in the WABCO brochure “Diagnosis - Product Overview” (815 010 037 3).

The diagnostic (OBD) socket is usually located in the driver’s cabin. Contact your vehicle manufacturer to find out where the connector is in your vehicle.

## 8.5.3 Diagnostic Software 246 301 221 0

There are three ways to obtain the diagnostic software:

- Offline as a USB stick version
- Online as a single download
- As a part of a WABCO system diagnostic subscription

For diagnosing multiple WABCO systems, WABCO offers you four different diagnostic software subscriptions via the Internet. These contain numerous diagnostic programs at a very competitive price.

For further information, ordering the diagnostic software in your language and loading it onto your PC please visit [www.wabco-auto.com/sd](http://www.wabco-auto.com/sd) on the internet.

## Operating the diagnostic software

After you have connected the vehicle, diagnostic interface and notebook to one another, start the diagnostic software matching your vehicle and EBS version.

! First, open the diagnostic memory under *Messages > Diagnostic memory* or click on the respective button for the diagnostic memory and save the input in a safe place. This allows you to distinguish later faults from present faults, e.g. which have been recorded during the start-up procedure and have been lost.

The software displays the vehicle configuration, ECU data and current fault messages. The diagnostic software can be operated using the menu as well as the different buttons.

Normally the control electronics recognizes the actual fault independently. In case you would like to initiate a complete diagnosis, click on the *Start Diagnosis* button or select the respective menu item in the *Diagnosis > Start menu*. The software will now check the individual components and log current detected faults. The software collates all the faults that occur in the diagnostic memory (*Messages > Diagnostic memory*). Current faults are coloured red in the overview and those that are not current are coloured blue. To obtain more information on a specific fault, select it and click the *Info* button.

To refresh the diagnostic memory, e.g. during repairs, click on the *Refresh* button or activate the *Cyclical update* control box.

If you have further questions concerning operation, use the *Help* menu.

# 9 Workshop instructions

---

**!** Observe all safety instructions, Kapitel „3 Safety instructions“, Seite 9. These instructions must be observed to avoid personal injury or material damage.

---

## 9.1 Replacing Components

EBS is maintenance-free. It monitors itself and its components. If a fault occurs, the driver is notified that the vehicle must be taken to the workshop or that the vehicle must be stopped.

For information on the fault detection function integrated into the EBS and possible deactivations of functions, Kapitel „8.1 Functions for Fault Detection“, Seite 32. The defective EBS system can be checked using the WABCO diagnostic software in a workshop, Kapitel „8.5 Diagnostic Services“, Seite 34.

### 9.1.1 Replacing Components

---

**!** Generally, repairing EBS components is not permitted. Only replacement of a complete component is possible.

---

- Read the corresponding component description in chapter 5 to obtain information on suitable replacement devices before a replacement.
- New parameters need to be set for the braking system when wheels with different tire sizes are used or there is a change regarding the permissible axle load of the vehicle. Your vehicle manufacturer must be consulted in this case.
- EBS tests and monitors itself. Resistances or tensions must only be measured on the wiring harness when the system signals a fault and when the diagnostic software signals this.
- Please note the special instructions for replacement of ESC-relevant components, Kapitel „5.3.4 Electronic Stability Control ESC“, Seite 15.

### 9.1.2 Disposal of old parts

When disposing of defective components, observe the current local, regional and national laws and legal regulations.

WABCO strives to protect the environment. As with other old devices, the component can be returned to WABCO. Contact your local WABCO partner for more details concerning disposal.

## 9.2 Test on the Roller Test Stand

Whether the legally required braking force is reached in the vehicle is usually determined by a test on a roller test stand in the workshop. For this purpose, it is necessary to brake each axle with the maximum possible force. At the same time the EBS brake management function, e.g. load dependent braking force control, must remain unaffected. This chapter therefore describes how you can activate the roller test stand function for an EBS vehicle to carry out the following required measurements.

### 9.2.1 Roller Test Stand Activation Process

To enter the roller test stand testing mode proceed as follows:

Switch off the ignition. Then switch on the braking system by actuating the brake pedal. The roller test stand function is now activated and you can turn on the ignition and the engine to fill the braking system. The test bench function remains active.

---

**!** If the on-board supply voltage is too low, the EBS device might reset when starting the engine. In this case, the roller test stand function is deactivated.

---

To deactivate the roller test stand function, accelerate the wheels on both axles to 3 km/h or accelerate the wheels of one axle to more than 12 km/h.

---

**!** Electronics such as the central module and the axle modulator must be specifically adjusted to the vehicle configuration by means of parameters.

---

## 9.3 Component Overview with part numbers

### 9.3.1 Overview of Spare Parts for EBS3 APAC

TITLE	PART NUMBER	DRAWING	SPECIFICATION NO.
Brake signal transmitter standard	series: 480 003 033 0	series: 480 003 033 0	series: 480 003 033 0
Brake signal transmitter w/ 90° turned lower ports (*)	series: 480 003 032 0	series: 480 003 032 0	series: 480 003 032 0
Brake signal transmitter w/o Filter, flatness cover w/ Voss Connector, bolts 891 490 852 4 (*)	series: 480 003 041 0	series: 480 003 041 0	series: 480 003 041 0
Brake signal transmitter w/ adaption for pedal plate, bolts (M6) 891 490 003 4 (*)	series: 480 003 042 0	series: 480 003 042 0	series: 480 003 042 0
Central module	series: 446 135 251 0 series: 446 135 250 0	series: 446 135 251 0 series: 446 135 250 0	series: 446 135 251 0 series: 446 135 250 0
Axle modulator 1M	series: 480 106 604 0	series: 480 106 600 0	series: 480 106 100 0
Axle modulator 1M w/ port 11 closed (*)	series: 480 106 603 0	series: 480 106 600 0	series: 480 106 100 0
Axle modulator 2M (4 pneumatic outputs 21.1 / 21.2 / 22.1 / 22.2) w/ filters (*)	series: 480 106 103 0	series: 480 106 100 0	series: 480 106 100 0
Axle modulator 2M (4 pneumatic outputs 21.1 / 21.2 / 22.1 / 22.2) w/o filters	series: 480 106 104 0	series: 480 106 100 0	series: 480 106 100 0
Trailer control valve w/o filter	series: 480 204 032 0	series: 480 204 032 0	series: 480 204 032 0
Trailer control valve w/ filter (*)	series: 480 204 031 0	series: 480 204 031 0	series: 480 204 031 0
ABS solenoid valve	Standard:(DIN bayonet series: 472 195 0xx 0 option: (Tyco HDSCS) series: 472 195 108 0	series: 472 195 0xx 0 series: 472 195 108 0	series: 472 195 0xx 0 series: 472 195 108 0
ATC solenoid valve	series: 472 170 606 0	series: 472 170 606 0	series: 472 170 606 0
Wheel speed sensors	series: 441 032 xxx 0	series: 441 032 xxx 0	series: 441 032 xxx 0
Adaptation of wheel speed sensors	–	–	series: 441 032 100 0
Pole wheels	–	–	895 905 000 4
ESC module	series: 446 065 052 0	series: 446 065 052 0	series: 446 065 052 0
Steering wheel angle sensor	series: 441 120 008 0 (or not delivered by WABCO)	series: 441 120 008 0 (or not delivered by WABCO)	series: 441 120 008 0 (or not delivered by WABCO)

## 9.3.2 Overview of Spare Parts for EBS3 Standard

TITLE	PART NUMBER	DRAWING	SPECIFICATION NO.
Brake signal transmitter for suspended pedal	series: 480 003 039 0	series: 480 003 039 0	series: 480 003 039 0
Brake signal transmitter w/ standing pedal (25°)	series: 480 002 102 0	series: 480 002 102 0	series: 480 002 102 0
Brake signal transmitter w/ standing pedal (46°)	series: 480 002 103 0	series: 480 002 103 0	series: 480 002 103 0
Central module	series: 446 135 240 0	series: 446 135 240 0	series: 446 135 240 0
Axle modulator 1M	series: 480 106 701 0	series: 480 106 700 0	series: 480 106 100 0
Axle modulator 2M (4 pneumatic outputs 2x 21 / 2x 22)	series: 480 106 201 0	series: 480 106 200 0	series: 480 106 100 0
Axle modulator 2M w/ gateway (4 pneumatic outputs 2x 21 / 2x 22)	series: 480 106 202 0	series: 480 106 200 0	series: 480 106 100 0
Trailer control valve	series: 480 204 031 0	series: 480 204 031 0	series: 480 204 031 0
ABS Solenoid valve	Standard: (with Tyco HDSCS) series: 472 195 039 0	series: 472 195 039 0	series: 472 195 039 0
ABS Solenoid valve	option: (with DIN bayonet) series: 472 195 0xx 0	series: 472 195 0xx 0	series: 472 195 0xx 0
Special relay valve	series: 973 011 300 0	series: 973 011 300 0	series: 973 011 300 0
Pressure limiting valve	series: 475 010 325 0	series: 475 010 325 0	series: 475 010 325 0
Wheel speed sensors	series: 441 032 xxx 0	series: 441 032 xxx 0	series: 441 032 xxx 0
Adaptation of wheel speed sensors	–	–	series: 441 032 100 0
Pole wheels	–	–	895 905 000 4
ESC module	series: 446 065 052 0	series: 446 065 052 0	series: 446 065 052 0
Steering wheel angle sensor	series: 441 120 008 0 (or not delivered by WABCO)	series: 441 120 008 0 (or not delivered by WABCO)	series: 441 120 008 0 (or not delivered by WABCO)











**WABCO**  
a **WORLD** of  
**DIFFERENCE**

**WABCO** (NYSE: WBC) is a leading global supplier of technologies and services that improve the safety, efficiency and connectivity of commercial vehicles. Founded nearly 150 years ago, WABCO continues to pioneer breakthrough innovations for advanced driver assistance, braking, stability control, suspension, transmission automation and aerodynamics. Partnering with the transportation

industry as it maps a route towards autonomous driving, WABCO also uniquely connects trucks, trailers, drivers, cargo, and fleet operators through telematics, as well as advanced fleet management and mobile solutions. WABCO reported sales of \$2.6 billion in 2015. Headquartered in Brussels, Belgium, WABCO has 12,000 employees in 39 countries. For more information, visit

[www.wabco-auto.com](http://www.wabco-auto.com)