

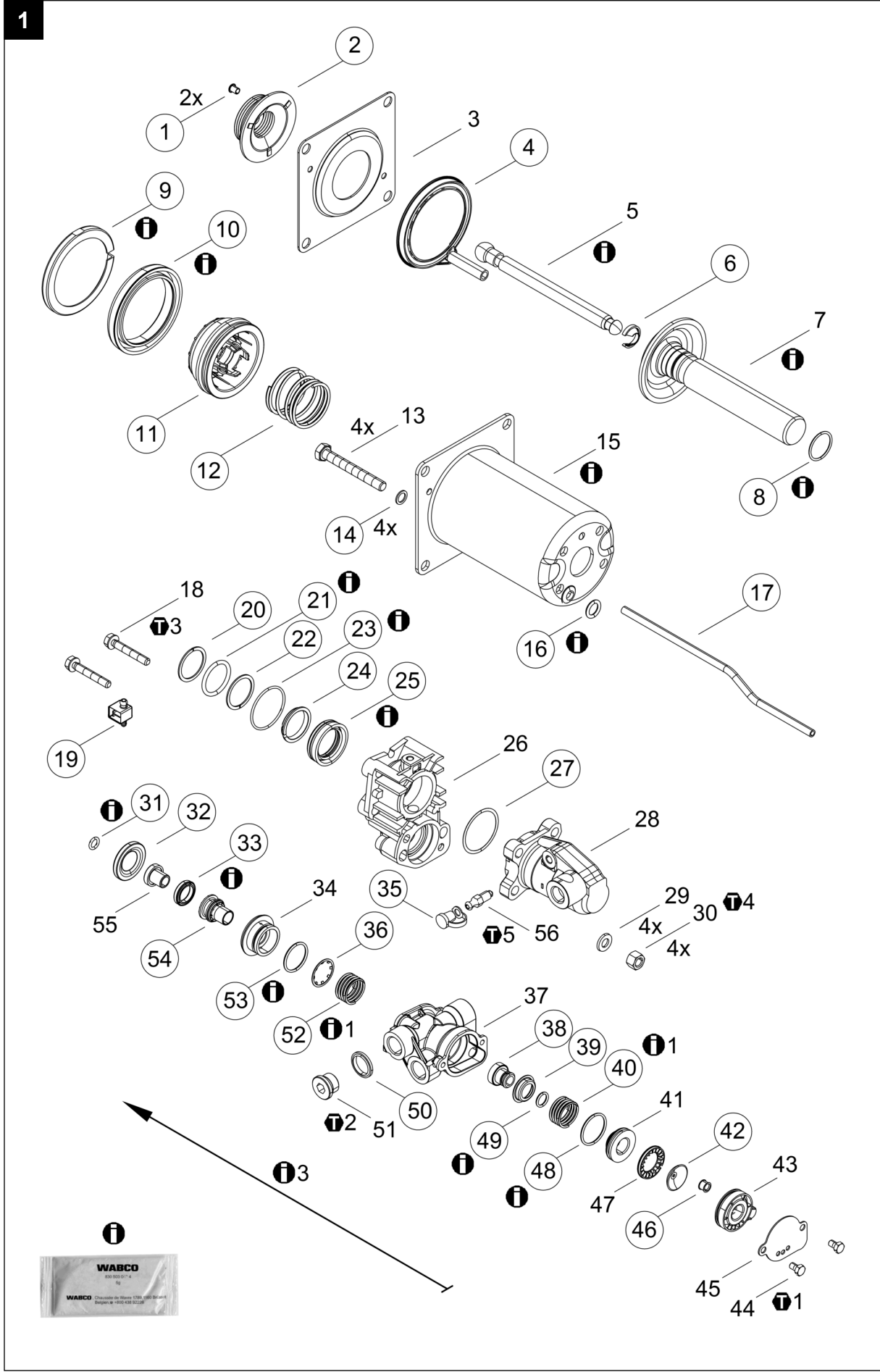

970 051 120 0
970 051 226 0
970 051 228 0

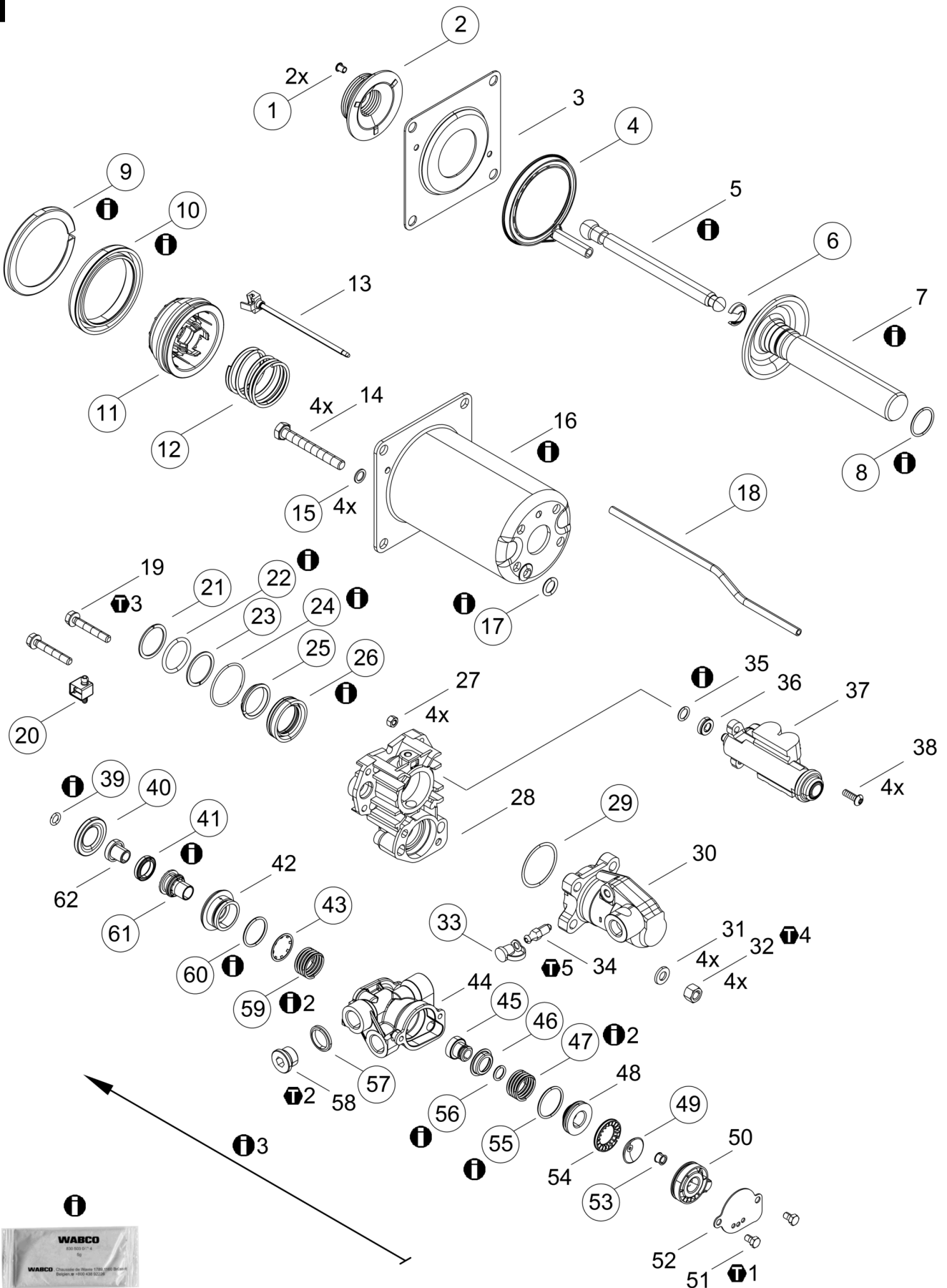







2



CS

Signální slova a symboly









-  **DANGER** NEBEZPEČÍ Bezprostředně hrozící nebezpečí: těžká újma na zdraví nebo smrt
-  **WARNING** POZOR Možná nebezpečná situace: jako následek lehká nebo středně těžká újma na zdraví nebo poškození majetku
-  **CAUTION** VÝSTRAHA Možná nebezpečná situace: jako následek těžká újma na zdraví nebo smrt
-  Díly, které mají číslo pozice v kroužku, jsou obsažené v opravárenské sadě.

-  Instrukce / informace ke správnému provedení opravy
-  Opravárenskou sadu je možné použít pro přístroje uvedené v tabulce.
-  Prvek utáhněte uvedeným točivým momentem příp. pomocí kontroly úhlu natočení.
- NOTE** Instrukce / informace ke správnému provedení opravy

Všeobecné pokyny k opravám





1. Opravárenské práce na přístrojích systému, který má vliv na bezpečnost vozidla, smí provádět pouze kvalifikovaný personál odborné servisní dílny.
3. Dodržujte předpisy BOZP podniku a národní předpisy.
5. S opravou začněte teprve tehdy, až všechny informace nutné pro opravu přečtete a porozumíte jim. Další potřebné dokumenty: zkušební postup, list náhradních dílů, všeobecné pokyny pro opravu a kontrolu (815 150 109 3) naleznete na internetových stránkách: www.wabco-auto.com, když v databázi INFORM zadáte produktové číslo přístroje nebo číslo dokumentu.
7. WABCO nepřebírá žádnou záruku za funkci nebo kvalitu opraveného přístroje.
2. Postupujte bezpodmínečně podle pokynů a instrukcí výrobce vozidla.
4. Používejte výhradně náhradní díly od firmy WABCO nebo díly schválené výrobcem vozidla.
6. Na adekvátním zařízení přezkoušejte – podle zkušebního postupu – každý opravený přístroj na funkčnost a těsnost.



Postup montáže

| Obrázek | Symbol | Utahovací moment: | Poznámky |
|------------|---|-------------------|---|
| 1+2 |  1 | 4.5 + 1.5 Nm | Před dalším pracovním krokem se ujistěte, že jsou všechny šrouby utaženy správným momentem. |
| 1+2 |  2 | 15 ± 5 Nm | |
| 1+2 |  3 | 10 ± 1 Nm | Před dalším pracovním krokem se ujistěte, že jsou všechny šrouby utaženy správným momentem. |
| 1+2 |  4 | 18 ± 3 Nm | |
| 1+2 |  5 | 5 + 5 Nm | |
| 1 |  1 | | 23 x 36±1 |
| 2 |  2 | | 22.5±0.25 x 31.7±1.5 |
| 1+2 |  3 | | Směr (orientace) montáže |
| 1+2 |  | | Namažte těsnící a kluzné plochy.GLK 112 830 502 087 4 |

de

Signalwörter & Symbole

-  **DANGER** GEFAHR Unmittelbar drohende Gefährdung: Schwere Personenschäden oder Tod
-  **WARNING** VORSICHT Mögliche Gefahrensituation: Leichte oder mittelschwere Personenschäden oder Sachschäden als Folge
-  **CAUTION** WARNUNG Mögliche Gefahrensituation: Tod oder schwere Personenschäden als Folge
-  Teile mit Kreis um die Positionsnummer sind im Reparatursatz enthalten.









-  Anweisung / Information für eine korrekte Reparatur
-  Der Reparatursatz kann für Geräte entsprechend Tabelle verwendet werden.
-  Element mit angegebenen Drehmoment bzw. Drehwinkel anziehen.
- NOTE** Anweisung / Information für eine korrekte Reparatur

de

Allgemeine Reparaturhinweise





1. Reparaturarbeiten an Geräten eines Fahrzeug-Sicherheitssystems darf nur qualifiziertes Personal einer Fachwerkstatt durchführen.
2. Leisten Sie den Vorgaben und Anweisungen des Fahrzeugherstellers unbedingt Folge.
3. Halten Sie Unfallverhütungsvorschriften des Betriebes sowie nationale Vorschriften ein.
4. Verwenden Sie ausschließlich von WABCO oder vom Fahrzeughersteller freigegebene Ersatzteile.
5. Beginnen Sie die Reparatur erst dann, wenn Sie alle Informationen, die für die Reparatur notwendig sind, gelesen und verstanden haben. Zusätzlich benötigte Dokumente: Prüfanweisung, Ersatzteilblatt, Allgemeine Reparatur- und Prüfhinweise (815 020 109 3) zu finden auf www.wabco-auto.com mittels Eingabe der Produktnummer des Gerätes bzw. Druckschriftennummer in INFORM.
6. Prüfen Sie jedes reparierte Gerät – gemäß Prüfanweisung – an einer adäquaten Einrichtung auf Funktionstüchtigkeit und Dichtigkeit.
7. WABCO übernimmt keinerlei Gewährleistung für die Funktion oder Qualität eines reparierten Gerätes



Montage Reihenfolge

| Bild | Symbol | Anzugsdrehmoment: | Bemerkungen |
|------------|---|-------------------|--|
| 1+2 |  1 | 4.5 + 1.5 Nm | Stellen Sie vor dem nächsten Arbeitsschritt sicher, dass alle Schrauben das richtige Anzugsmoment haben. |
| 1+2 |  2 | 15 ± 5 Nm | |
| 1+2 |  3 | 10 ± 1 Nm | Stellen Sie vor dem nächsten Arbeitsschritt sicher, dass alle Schrauben das richtige Anzugsmoment haben. |
| 1+2 |  4 | 18 ± 3 Nm | |
| 1+2 |  5 | 5 + 5 Nm | |
| 1 |  1 | | 23 x 36±1 |
| 2 |  2 | | 22.5±0.25 x 31.7±1.5 |
| 1+2 |  3 | | Montagerichtung |
| 1+2 |  1 | | Fetten Sie die Dicht- und Gleitflächen ein. GLK 112 830 502 087 4 |

en

Symbols & Signal Words

-  **DANGER** Imminent hazard situation: serious personal injury or death as a result
-  **WARNING** Possible hazard situation: minor or moderate personal injury or material loss as a result
-  **CAUTION** Possible hazard situation: serious personal injury or death as a result
-  Parts having item numbers with circles are included in the kit.









-  Instruction / Information for a correct repair
-  The kit can be used for devices according table.
-  Tighten element with specified torque or angle of rotation.
- NOTE** Instruction / Information for a correct repair

General Repair Hints

1. Only qualified personnel of a specialist workshop are authorized to perform repair work on a vehicle's security system.
2. Absolutely follow specifications and instructions of vehicle manufacturer.
3. Keep to company's relevant accident prevention regulations and national regulations.
4. Use only spare parts released by WABCO or vehicle manufacturer.
5. Always start repair work only when you have read and understood all information required for repair. Documents additionally needed: Test Instruction, Spare Parts List, General Repair and Test Hints (815 010 109 3) to be found on www.wabco-auto.com by entering product number of the device or the publication number in INFORM.
6. Check each repaired equipment for functional efficiency and tightness on an adequate facility according to the test instruction.
7. WABCO does not accept any liability or responsibility for the quality or functionality of a repaired device





en



Sequence of assembly

| Picture | Symbol | Torque: | Comments |
|------------|---|--------------|--|
| 1+2 |  1 | 4.5 + 1.5 Nm | Ensure accurate torque at all screws before next step. |
| 1+2 |  2 | 15 ± 5 Nm | |
| 1+2 |  3 | 10 ± 1 Nm | Ensure accurate torque at all screws before next step. |
| 1+2 |  4 | 18 ± 3 Nm | |
| 1+2 |  5 | 5 + 5 Nm | |
| 1 |  1 | | 23 x 36±1 |
| 2 |  2 | | 22.5±0.25 x 31.7±1.5 |
| 1+2 |  3 | | Assembly direction |
| 1+2 |  4 | | Lubricate sealing and sliding surfaces.GLK 112 830 502 087 4 |

es

Símbolos & Palabras de aviso

-  **DANGER** PELIGRO Situación de peligro inminente: Pueden ocasionarse daños personales graves o incluso mortales
-  **WARNING** CUIDADO Posible situación de peligro: Pueden ocasionarse daños personales leves o moderados o pérdidas materiales
-  **CAUTION** ADVERTENCIA Posible situación de peligro: Pueden ocasionarse daños personales graves o incluso mortales
-  Los componentes incluidos en el kit son los números que aparecen con círculo.









-  Instrucciones/Información para una correcta reparación
-  El kit puede ser utilizado en los equipos que aparecen en la tabla.
-  Apretar el elemento con el par de apriete o ángulo de giro indicado.
- NOTE** Instrucciones/Información para una correcta reparación

Consejos generales de reparación

1. Sólo el personal cualificado de un taller especializado está autorizado para realizar las tareas de reparación en los sistemas de seguridad de los vehículos.
3. Siga las regulaciones y normas acerca de prevención de riesgos laborales de su empresa y de su país.
5. Comience la reparación sólo cuando haya leído y comprendido las instrucciones de reparación. Documentos adicionales necesarios: Instrucciones de comprobación, listas de despiece, consejos generales de comprobación y reparación (815 040 109 3), los cuales pueden encontrarse en www.wabco-auto.com, introduciendo la referencia del aparato o la referencia de la publicación en la aplicación INFORM.
7. WABCO no asume garantía alguna por el funcionamiento o calidad de un equipo reparado.
2. Atenerse exactamente a las indicaciones e instrucciones del fabricante del vehículo.
4. Utilice piezas de repuesto suministradas por WABCO o el fabricante del vehículo.
6. Compruebe la eficacia de funcionamiento y de ajuste de cada equipo reparado en unas instalaciones adecuadas según las instrucciones de comprobación.





es

Montaje sucesión

| Dibujos | Símbolo | Par de apriete: | Observaciones |
|------------|---|-----------------|---|
| 1+2 |  1 | 4.5 + 1.5 Nm | Asegúrese de aplicar el par de apriete adecuado en todos los tornillos antes de pasar al siguiente punto. |
| 1+2 |  2 | 15 ± 5 Nm | |
| 1+2 |  3 | 10 ± 1 Nm | Asegúrese de aplicar el par de apriete adecuado en todos los tornillos antes de pasar al siguiente punto. |
| 1+2 |  4 | 18 ± 3 Nm | |
| 1+2 |  5 | 5 + 5 Nm | |
| 1 |  1 | | 23 x 36±1 |
| 2 |  2 | | 22.5±0.25 x 31.7±1.5 |
| 1+2 |  3 | | La dirección de la asamblea |
| 1+2 |  4 | | Las juntas y las superficies deslizantes deben lubricarse. GLK 112 830 502 087 4 |

fr

Symboles & Significations

-  **DANGER** DANGER Situation de danger imminent : Danger de mort ou de dommage corporel sérieux.
-  **WARNING** ATTENTION Situation de danger probable : Risque de dommage corporel mineur ou modéré ou perte de matériel.
-  **CAUTION** AVERTISSEMENT Situation de danger de danger probable : Danger de mort ou de dommages corporel sérieux
-  Les composants avec repères entourés sont inclus dans le kit.

 Instruction/Information pour une réparation correcte

 Le kit peut être utilisé pour les appareils indiqués sur le Feuillelet.

 Serrer l'élément avec le couple et la position angulaire indiqués.









NOTE Instruction/Information pour une réparation correcte

Conseils généraux de réparation

1. Uniquement le personnel qualifié d'un atelier agréé WABCO est autorisé à effectuer la réparation sur les systèmes de sécurité d'un véhicule.
2. Respecter toujours les prescriptions et instructions du constructeur du véhicule.
3. Veillez aux règlements de prévention des accidents indiqués par votre société et aux règlements nationaux.
4. Employez seulement les pièces de rechange WABCO ou du constructeur du véhicule.
5. Commencez toujours le travail de réparation seulement après avoir lu et compris toutes les informations indiquées pour la réparation. Documentation complémentaire nécessaire : Instruction d'essai, liste des pièces détachées, instructions de réparation et conseils d'essai (815 030 109 3) en tapant la référence du produit ou le numéro de la publication dans INFORM sur internet : www.wabco-auto.com
6. Examinez chaque appareil réparé pour s'assurer de l'efficacité fonctionnelle et de l'étanchéité selon l'instruction d'essai.
7. WABCO n'assume aucune garantie quant au fonctionnement ou à la qualité d'un appareil réparé.





fr

Les montages ordre

| Image | Symbole | Couple de serrage: | Remarques |
|------------|---|--------------------|---|
| 1+2 |  1 | 4.5 + 1.5 Nm | Assurez-vous d'un couple correct à toutes les vis avant l'étape suivante |
| 1+2 |  2 | 15 ± 5 Nm | |
| 1+2 |  3 | 10 ± 1 Nm | Assurez-vous d'un couple correct à toutes les vis avant l'étape suivante |
| 1+2 |  4 | 18 ± 3 Nm | |
| 1+2 |  5 | 5 + 5 Nm | |
| 1 |  1 | | 23 x 36±1 |
| 2 |  2 | | 22.5±0.25 x 31.7±1.5 |
| 1+2 |  3 | | Sens du montage |
| 1+2 |  4 | | Les surfaces d'étanchéité et de frottement doivent être graissées.GLK 112 830 502 087 4 |

hr

Simboli & Značenja

-  **DANGER** OPREZ Neposredna rizična situacija: moguće ozbiljno ozljeđivanje ili smrt
-  **WARNING** OPASNOST neposredna rizična situacija: moguće manje ozljeđivanje materijalna šteta
-  **CAUTION** UPOZORENJE Neposredna rizična situacija: moguće ozbiljno ozljeđivanje ili smrt
-  Dijelovi uređaja čiji su brojevi zaokruženi nalaze se u kompletu..

 Informacija o ispravnom popravku.

 Set može biti korišten za uređaje prema tabeli.









 Zategnite element primjenom navedenog zakretnog momenta ili zakretnog kuta.

NOTE Informacija o ispravnom popravku.

Opće upute o popravcima





1. Samo kvalificirane osobe istručnjaci smiju popravljati siguronosne sustave na vozilu.
3. Provodi tvrtkine siguronosne propise kao i nacionalne propise o sigurnosti
5. Popravak počni tek nakon što pročitaš i shvatiš upute o popravku. Potrebni dokumenti: Instrukcije o testiranju, Lista rezervnih dijelova, Opće natuknice o popravku i testiranju (815 010 109 3) mogu se naći na www.wabco-auto.com nakon upisa kataloškog broja proizvoda ili publikacije u INFORM-u.
7. WABCO ne preuzima odgovornost za rad i kvalitetu popravljenog uređaja.
2. U potpunosti slijedi specifikacije i upute proizvođača vozila.
4. Koristi rezervne dijelove proizvedene od WABCA ili proizvođača vozila..
6. Provjeri svaki popravljeni uređaj kako radi i da li je zategnuto sve kako treba prema odgovarajućim uputama o testiranju proizvoda.



Redoslijed ugradnje

| Slika | Simbol | Zakretni moment: | Komentar |
|------------|---|------------------|--|
| 1+2 |  1 | 4.5 + 1.5 Nm | Provjeri da su vijci stegnuti ispravno odgovarajućom silom zatezanja prije slijedećeg koraka |
| 1+2 |  2 | 15 ± 5 Nm | |
| 1+2 |  3 | 10 ± 1 Nm | Provjeri da su vijci stegnuti ispravno odgovarajućom silom zatezanja prije slijedećeg koraka |
| 1+2 |  4 | 18 ± 3 Nm | |
| 1+2 |  5 | 5 + 5 Nm | |
| 1 |  1 | | 23 x 36±1 |
| 2 |  2 | | 22.5±0.25 x 31.7±1.5 |
| 1+2 |  3 | | Smjer ugradnje. |
| 1+2 |  4 | | Brtvene i klizne površine treba podmazati.GLK 112 830 502 087 4 |

it

Simboli e Segnali









-  **DANGER** PERICOLO Imminente situazione di rischio: serie ferite personali fino anche alle morte
-  **WARNING** PRUDENZA Possibili situazioni di pericolo: possibili lievi ferite o perdita di materiale
-  **CAUTION** AVVERTENZA Possibili situazioni di pericolo: serie ferite personali fino anche alle morte
-  I componenti indicati con un numero cerchiato, sono inclusi nel kit.

-  Istruzioni/Informazioni per unacorretta riparazione
-  Il kit può essere usato per gli articoli secondo la tabella.
-  Serrare l'elemento con la coppia/angolo di rotazione indicati.
- NOTE** Istruzioni/Informazioni per unacorretta riparazione

Suggerimenti per la riparazione





1. Soltanto il personale qualificato delle officine specializzate è autorizzato ad effettuare le riparazioni sui sistemi di sicurezza dei veicoli.
3. Attenersi alle norme nazionali e aziendali in merito alla prevenzione degli infortuni.
5. Effettuare la riparazione solamente dopo aver letto e capito tutte le informazioni richieste per la riparazione. Ulteriori informazioni necessarie: istruzioni di collaudo, catalogo dei ricambi, cenni generali sulla riparazione e test (815 050 109 3) possono essere trovati sul sito www.wabco-auto.com alla voce INFORM entrando per codice del dell'apparecchio o per numero della pubblicazione.
7. WABCO non si assume alcuna responsabilità per il funzionamento o la qualità di un apparecchio riparato.
2. E' assolutamente necessario seguire le istruzioni e le specifiche del costruttore del veicolo.
4. Usare solo ricambi originali WABCO o del costruttore del veicolo.
6. Controllare la funzionalità e l'efficienza di ogni apparecchiatura riparata secondo le istruzioni riportate nel manuale di collaudo.



Sequenza di montaggio

| Figura | Simbolo | Coppia di serraggio: | Note |
|------------|---|----------------------|---|
| 1+2 |  1 | 4.5 + 1.5 Nm | Assicurarsi prima dell'operazione di lavoro successiva che tutte le viti abbiano la corretta coppia di serraggio. |
| 1+2 |  2 | 15 ± 5 Nm | |
| 1+2 |  3 | 10 ± 1 Nm | Assicurarsi prima dell'operazione di lavoro successiva che tutte le viti abbiano la corretta coppia di serraggio. |
| 1+2 |  4 | 18 ± 3 Nm | |
| 1+2 |  5 | 5 + 5 Nm | |
| 1 |  1 | | 23 x 36±1 |
| 2 |  2 | | 22.5±0.25 x 31.7±1.5 |
| 1+2 |  3 | | Verso di montaggio |
| 1+2 |  1 | | Superfici di tenuta e di scorrimento devono essere lubrificate. GLK 112 830 502 087 4 |

pl

Hasła ostrzegawcze i symbole

-  **DANGER** NIEBEZPIECZEŃSTWO Bezpośrednie zagrożenie ciężkimi obrażeniami bądź śmiercią.
-  **WARNING** UWAGA! Niebezpieczeństwo grożące lekkimi bądź średnimi obrażeniami.
-  **CAUTION** OSTRZEŻENIE Niebezpieczeństwo grożące śmiercią bądź ciężkimi obrażeniami.
-  Części oznaczone kółkiem wokół numeru pozycji należą do zestawu naprawczego.









-  Wskazówki / Informacje dotyczące poprawnej naprawy.
-  Zestaw naprawczy może być używany do urządzeń według tabeli.
-  Dokręcić element podanym momentem obrotowym.
- NOTE** Wskazówki / Informacje dotyczące poprawnej naprawy.

pl

Ogólne porady naprawcze





1. Prace naprawcze w obrębie urządzeń układu bezpieczeństwa pojazdu mogą być wykonane jedynie przez wykwalifikowany personel specjalistycznego warsztatu.
3. Należy przestrzegać zakładowych i krajowych przepisów BHP.
5. Naprawę należy rozpocząć dopiero wówczas, gdy wszystkie potrzebne do niej informacje zostaną przeczytane i zrozumiane. Dokumenty potrzebne dodatkowo: instrukcja kontrolna, tabela części zamiennych, ogólne wskazówki dotyczące naprawy i kontroli (815 020 109 3) znajdują Państwo na stronie internetowej www.wabco-auto.com, podając numer urządzenia bądź numer publikacji w bazie INFORM.
7. WABCO nie udziela żadnej gwarancji na działanie lub jakość naprawionego urządzenia.
2. Należy koniecznie postępować według wytycznych i wskazówek producenta pojazdu.
4. Należy używać wyłącznie części zamiennych dopuszczonych przez firmę WABCO bądź przez producenta pojazdu.
6. Na odpowiednim urządzeniu należy sprawdzić każde naprawiane urządzenie - zgodnie z instrukcją kontrolną - pod kątem sprawności działania i szczelności.



Kolejność montażu

| Obraz | Symbol | Moment dokręcania: | Komentarz |
|------------|---|--------------------|---|
| 1+2 |  1 | 4.5 + 1.5 Nm | Sprawdź właściwy moment we wszystkich śrubach przed przystąpieniem do następnego kroku. |
| 1+2 |  2 | 15 ± 5 Nm | |
| 1+2 |  3 | 10 ± 1 Nm | Sprawdź właściwy moment we wszystkich śrubach przed przystąpieniem do następnego kroku. |
| 1+2 |  4 | 18 ± 3 Nm | |
| 1+2 |  5 | 5 + 5 Nm | |
| 1 |  1 | | 23 x 36±1 |
| 2 |  2 | | 22.5±0.25 x 31.7±1.5 |
| 1+2 |  3 | | Kierunek montażu |
| 1+2 |  4 | | Należy nasmarować powierzchnie uszczelniające i ślizgowe. GLK 112 830 502 087 4 |

ru

Знаки & символы

-  **DANGER** ОПАСНО Прямая угроза аварийной ситуации: влечет за собой смерть или тяжелые повреждения
-  **WARNING** ОСТОРОЖНО Опасная ситуация: последствием являются легкие повреждения или повреждения средней тяжести, а также материальный ущерб
-  **CAUTION** ПРЕДУПРЕЖДЕНИЕ Опасная ситуация: влечет за собой смерть или тяжелые повреждения
-  Номера частей, обведенные кружком, Вы найдете в ремкомплекте.









-  Указание/информация для проведения надлежащего ремонта
-  Ремкомплект может быть использован для приборов соответственно таблице.
-  Затянуть элемент с заданным моментом затяжки или на заданный угол поворота.
- NOTE** Указание/информация для проведения надлежащего ремонта

ru

Общие указания по ремонту





1. Провождение ремонта приборов данной системы должно производиться только квалифицированным персоналом в специализированной мастерской.
2. Следуйте предписаниям и инструкциям изготовителя транспортного средства.
3. Соблюдайте предписания предприятия по технике безопасности, а также национальные нормы.
4. Используйте только запчасти, допущенные к использованию компанией Wabco или производителем транспортного средства.
5. Проводите ремонт только после того, как вы прочитали и поняли все информации, необходимые для данного процесса. Дополнительные документы: инструкция по тестированию, список запасных частей, общие инструкции по ремонту и проведению испытаний (815 080 109 3) Вы найдете на www.wabco-auto.com. Для этого необходимо задать номер нужного прибора или номер брошюры в INFORM.
6. Проконтролируйте каждый отремонтированный прибор- согласно инструкции по тестированию- на работоспособность и герметичность с помощью соответствующего оборудования.
7. Компания WABCO не принимает на себя какую-либо ответственность за работу или качество отремонтированных устройств.



Порядок действий при монтаже.

| Изображение | Символ | Момент сопротивления: | Замечания |
|-------------|---|-----------------------|--|
| 1+2 |  1 | 4.5 + 1.5 Nm | Перед следующим этапом работ убедитесь в том, что для всех винтов применен соответствующий момент затяжки. |
| 1+2 |  2 | 15 ± 5 Nm | |
| 1+2 |  3 | 10 ± 1 Nm | Перед следующим этапом работ убедитесь в том, что для всех винтов применен соответствующий момент затяжки. |
| 1+2 |  4 | 18 ± 3 Nm | |
| 1+2 |  5 | 5 + 5 Nm | |
| 1 |  1 | | 23 x 36±1 |
| 2 |  2 | | 22.5±0.25 x 31.7±1.5 |
| 1+2 |  3 | | Направление, в котором производится монтаж |
| 1+2 |  4 | | Смажьте поверхности уплотнения / скольжения. GLK 112 830 502 087 4 |

tr

Semboller&belirti sözləri

-  **DANGER** TEHLİKE Tehlikeli durum: ciddi personel yaralanması veya ölüm riski.
-  **WARNING** DİKKAT Tehlike riski: hafif personel yaralanması veya maddi zarar.
-  **CAUTION** UYARI Ciddi personel yaralanması veya ölüm riski.
-  Yuvarlak içinde numarası belirtilen parça numaraları kit içerisinde bulunur.









-  Talimat/ Doğru tamir için bilgi
-  Tabloda belirtilen parçalar için kit kullanılabilir.
-  Elemanı belirtilen sıkma torku ya da dönme açısı ile sıkın.
- NOTE** Talimat/ Doğru tamir için bilgi

Genel tamir bilgisi

1. Araçların güvenlik sistemlerinde tamir işlemlerini yalnızca eğitim almış konusunda uzman personeller gerçekleştirebilir.
2. Araç üretici firma özellikler ve talimatlarına kesinlikle uyunuz.
3. Şirket emniyet kuralları ve ulusal regülasyonlarına uyunuz.
4. Sadece WABCO veya üretici firma tarafından yayınlanan yedek parçaları kullanın.
5. Tamire, tamir işlemi için gerekli olan tüm bilgileri okuyup anladıktan sonra başlayınız. Ayrıca gerekli olan dokümanlar: Test talimatı, yedek parça sayfası, genel tamir ve test bilgileri (815 140 109 3). Tümünü linki altında, online ürün kataloğu INFORM'da cihaza ait ürün numarasını veya baskı numarasını girerek bulabilirsiniz.
6. Tamir edilmiş her cihazı - test talimatına uygun şekilde - uygun bir donanımla işlevsellik ve sızdırmazlık konusunda kontrol edin.
7. WABCO tamir edilmiş bir cihazın işlevselliği veya kalitesi için hiçbir sorumluluk üstlenmemektedir.





tr



Montaj sırası

| Resim | Sembol | Tork: | Yorumlar |
|------------|---|--------------|---|
| 1+2 |  1 | 4.5 + 1.5 Nm | Bir sonraki iş adımımdan önce, tüm civataların doğru torca sahip olduklarından emin olun. |
| 1+2 |  2 | 15 ± 5 Nm | |
| 1+2 |  3 | 10 ± 1 Nm | Bir sonraki iş adımımdan önce, tüm civataların doğru torca sahip olduklarından emin olun. |
| 1+2 |  4 | 18 ± 3 Nm | |
| 1+2 |  5 | 5 + 5 Nm | |
| 1 |  1 | | 23 x 36±1 |
| 2 |  2 | | 22.5±0.25 x 31.7±1.5 |
| 1+2 |  3 | | Montaj yönü |
| 1+2 |  4 | | Conta ve sürtünme ile çalışan yüzeyler yağlanmalıdır.GLK 112 830 502 087 4 |

pt

Símbolos e Significados









-  **DANGER** Perigo! Risco de acidente iminente: lesão corporal grave e/ou risco de morte.
-  **WARNING** Cuidado! Possível situação de acidente: ferimentos leves/moderados e/ou danos materiais.
-  **CAUTION** Atenção! Possível situação de acidente: lesão corporal grave e/ou risco de morte.
-  Componentes que estão marcados com um círculo compõem o jogo de reparo.

-  Instrução/Informação para uma correta reparação.
-  O jogo de reparo pode ser utilizado nos produtos relacionados na tabela.
-  Apertar o elemento com o binário ou o ângulo de rotação indicado.
- NOTE** Instrução/Informação para uma correta reparação.

Dicas Gerais para Reparação





1. Por motivo de segurança, somente pessoas qualificadas devem efetuar reparação nos sistemas de freio do veículo.
3. Mantenha e siga as orientações de prevenção de acidentes vigentes e/ou impostas pelos órgãos competentes.
5. Somente inicie o trabalho de reparação após ler e entender todas as informações necessárias para realizar uma reparação. Documentos adicionais necessários: instrução de teste, lista de peças sobressalentes, dicas gerais de testes e reparação (815 130 109 3) podem ser encontrados no site www.wabco-auto.com ao inserir o número do produto.
7. A WABCO não assume qualquer responsabilidade pela função ou qualidade de um equipamento reparado.
2. Siga sempre as recomendações/especificações do fabricante do veículo.
4. Use somente peças de reposição aprovadas pela WABCO ou pelo fabricante do veículo.
6. Verificar cada produto reparado conforme instruções de teste, utilizando os equipamentos necessários e local adequado.

Sequência de montagem

| Figura | Símbolo | Torque: | Comentários |
|------------|---|--------------|--|
| 1+2 |  1 | 4.5 + 1.5 Nm | O manuseamento deste componente requer uma proteção contra a descarga eletrostática (ESD). |
| 1+2 |  2 | 15 ± 5 Nm | |
| 1+2 |  3 | 10 ± 1 Nm | O manuseamento deste componente requer uma proteção contra a descarga eletrostática (ESD). |
| 1+2 |  4 | 18 ± 3 Nm | |
| 1+2 |  5 | 5 + 5 Nm | |
| 1 |  1 | | 23 x 36±1 |
| 2 |  2 | | 22.5±0.25 x 31.7±1.5 |
| 1+2 |  3 | | Sequência de montagem |
| 1+2 |  4 | | Superfícies de vedação e deslizamento devem ser lubrificadasGLK 112 830 502 087 4 |

ro

Simboluri și cuvinte pentru avertizare

-  **DANGER** Situație de pericol iminentă: poate rezulta vătămare corporală gravă sau deces.
-  **WARNING** Posibilă situație de pericol: pot rezulta vătămări corporale minore sau medii sau pagube materiale
-  **CAUTION** Posibilă situație de pericol: poate rezulta vătămare corporală gravă sau deces
-  Piesele cu numărul de articol încercuit sunt incluse în kit.

 Instrucțiuni / Informare pentru o reparare corectă

 Kitul poate fi folosit pentru dispozitive, conform tabelului.



















 Strângeți elementul cu cuplul, respectiv unghiul de rotire indicat.

NOTE Instrucțiuni / Informare pentru o reparare corectă

Instrucțiuni generale referitoare la reparație

1. Numai personalul calificat al unui atelier de service specializat este autorizat să efectueze lucrări de reparații pe sistemul de siguranță al vehiculului.
3. Respectați prevederile firmei și cele naționale pentru prevenirea accidentelor.
5. Întotdeauna începeți lucrările de reparații numai după ce ați citit și înțeles toate informațiile necesare pentru reparație. Documente suplimentare necesare: Instrucțiuni de testare, Lista pieselor de schimb, Instrucțiuni generale pentru reparație și testare (815 110 109 3) pot fi găsite pe www.wabco-auto.com introducând codul dispozitivului în INFORM.
7. WABCO nu garantează sau nu răspunde pentru funcționarea și calitatea unui dispozitiv reparat.
2. Respectați obligatoriu instrucțiunile date de producătorul vehiculului.
4. Utilizați exclusiv piese de schimb autorizate de WABCO sau de producătorul autovehiculului.
6. Verificați eficiența funcțională și etanșeitatea fiecărui echipament reparat pe o instalație adecvată în conformitate cu instrucțiunile de testare.

Secvența asamblării

| Imagine | Simbol | Moment de torsiune: | Comentarii |
|---|---|---------------------|---|
|  |  1 | 4.5 + 1.5 Nm | Înainte de următoarea etapă de lucru, asigurați-vă că toate șuruburile au momentul de strângere corect. |
|  |  2 | 15 ± 5 Nm | |
|  |  3 | 10 ± 1 Nm | Înainte de următoarea etapă de lucru, asigurați-vă că toate șuruburile au momentul de strângere corect. |
|  |  4 | 18 ± 3 Nm | |
|  |  5 | 5 + 5 Nm | |
|  |  1 | | 23 x 36±1 |
|  |  2 | | 22.5±0.25 x 31.7±1.5 |
|  |  3 | | Direcția de asamblare |
|  |  | | Suprafețele de etanșare și alunecare trebuie să fie lubrificate.GLK 112 830 502 087 4 |