

1

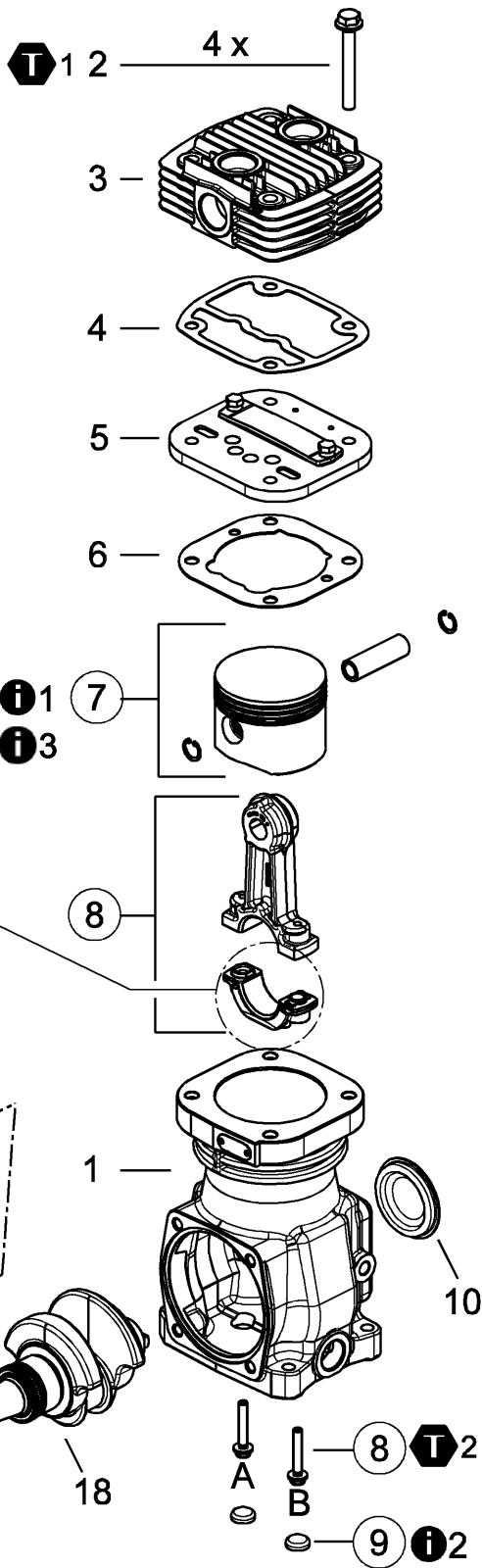

- 411 141 000 0
- 411 141 002 0
- 411 141 003 0
- 411 141 004 0
- 411 141 006 0
- ↓
- 411 141 011 0
- 411 141 501 0
- 411 141 503 0
- 411 141 504 0
- 411 141 506 0
- 411 141 507 0
- 411 141 551 0
- 411 141 552 0
- 411 141 640 0
- 411 141 702 0
- 411 141 703 0
- 411 141 800 0
- 411 141 805 0
- 411 141 818 0
- 411 141 835 0
- 411 141 845 0
- 411 141 910 0
- 411 141 930 0





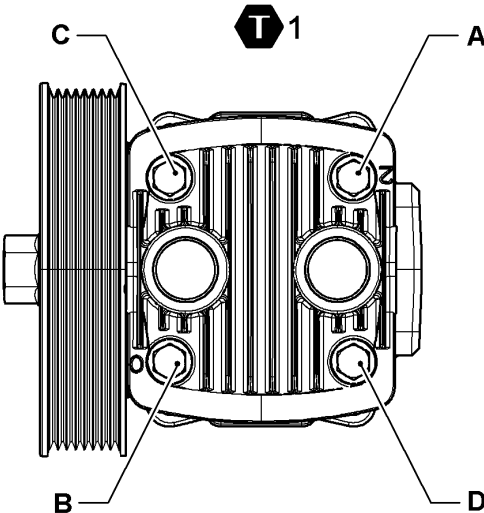

2

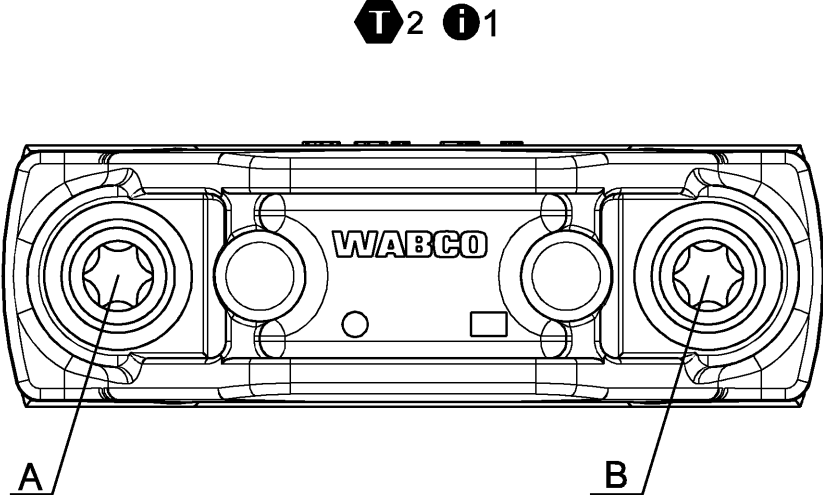



3



Signalwörter & Symbole

-  **DANGER** Beschreibung einer unmittelbaren Situation, die bei Nichtbeachtung des Warnhinweises irreversible Verletzungen oder Tod zur Folge hat.
-  **WARNING** Beschreibung einer möglichen Situation, die bei Nichtbeachtung des Warnhinweises reversible Verletzungen zur Folge haben kann.
-  **CAUTION** Beschreibung einer möglichen Situation, die bei Nichtbeachtung des Warnhinweises irreversible Verletzungen oder Tod zur Folge haben kann.
-  Teile mit Kreis um die Positionsnummer sind im Reparatursatz enthalten.











-  Anweisung / Information für eine korrekte Reparatur
-  Der Reparatursatz kann für Geräte entsprechend Tabelle verwendet werden.
-  Element mit angegebenen Drehmoment bzw. Drehwinkel anziehen.

NOTE Anweisung / Information für eine korrekte Reparatur

Allgemeine Reparaturhinweise





1. Reparaturarbeiten an Geräten eines Fahrzeug-Sicherheitssystems darf nur qualifiziertes Personal einer Fachwerkstatt durchführen.
3. Halten Sie Unfallverhütungsvorschriften des Betriebes sowie nationale Vorschriften ein.
5. Beginnen Sie die Reparatur erst dann, wenn Sie alle Informationen, die für die Reparatur notwendig sind, gelesen und verstanden haben. Zusätzlich benötigte Dokumente: Prüfanweisung, Ersatzteilblatt, Allgemeine Reparatur- und Prüfhinweise (815 020 109 3) zu finden auf www.wabco-auto.com mittels Eingabe der Produktnummer des Gerätes bzw. Druckschriftennummer in INFORM.
7. WABCO übernimmt keinerlei Gewährleistung für die Funktion oder Qualität eines reparierten Gerätes
2. Leisten Sie den Vorgaben und Anweisungen des Fahrzeugherstellers unbedingt Folge.2
4. Verwenden Sie ausschließlich von WABCO oder vom Fahrzeughersteller freigegebene Ersatzteile.
6. Prüfen Sie jedes reparierte Gerät – gemäß Prüfanweisung – an einer adäquaten Einrichtung auf Funktionstüchtigkeit und Dichtigkeit.



Montage Reihenfolge

| Bild | Symbol | Reihenfolge: | Anzugsdrehmoment: | Weiterdrehwinkel: | Bemerkungen |
|------------|---|--------------|-------------------|-------------------|--|
| 1+3 |  1 | | | | Einbaulage beachten. |
| 1 |  3 | | | | Sicherstellen, dass die Kolbenringe während ein oder ausbau nicht beschädigt werden. |
| 1+3 |  2 | A, B | 6 ± 0.6 Nm | | Stellen Sie vor dem nächsten Arbeitsschritt sicher, dass alle Schrauben das richtige Anzugsmoment haben. |
| 1+3 |  | A, B | | 70° +15° / -5° | Arbeitsschritte nacheinander durchführen |
| 1 |  5 | | 12 ± 1.2 Nm | | Stellen Sie vor dem nächsten Arbeitsschritt sicher, dass alle Schrauben das richtige Anzugsmoment haben. |
| 1 |  2 | | | | Säubern und öldicht einpressen. Einkleben mit Loctite 648. |
| 1+2 |  1 | A, B, C, D | 20 ± 2 Nm | | Stellen Sie vor dem nächsten Arbeitsschritt sicher, dass alle Schrauben das richtige Anzugsmoment haben. |
| 1+2 |  | A, B, C, D | | 90° +10° / -5° | Arbeitsschritte nacheinander durchführen |
| 1 |  3 | | 100 ± 10 Nm | | Stellen Sie vor dem nächsten Arbeitsschritt sicher, dass alle Schrauben das richtige Anzugsmoment haben. |
| 1 |  4 | | 32 ± 2 Nm | | |

en

Symbols & Signal Words





















-  **DANGER** Description of an immediate situation which will result in irreversible injury or death if the warning is ignored.
-  **WARNING** Description of a possible situation which may result in irreversible injury if the warning is ignored.
-  **CAUTION** Description of a possible situation which may result in irreversible injury or death if the warning is ignored.
-  Parts having item numbers with circles are included in the kit.

-  Instruction / Information for a correct repair
-  The kit can be used for devices according table.
-  Tighten element with specified torque or angle of rotation.
- NOTE** Instruction / Information for a correct repair

General Repair Hints

1. Only qualified personnel of a specialist workshop are authorized to perform repair work on a vehicle's security system.
3. Keep to company's relevant accident prevention regulations and national regulations.
5. Always start repair work only when you have read and understood all information required for repair. Documents additionally needed: Test Instruction, Spare Parts List, General Repair and Test Hints (815 010 109 3) to be found on www.wabco-auto.com by entering product number of the device or the publication number in INFORM.
7. WABCO does not accept any liability or responsibility for the quality or functionality of a repaired device
2. Absolutely follow specifications and instructions of vehicle manufacturer.2
4. Use only spare parts released by WABCO or vehicle manufacturer.
6. Check each repaired equipment for functional efficiency and tightness on an adequate facility according to the test instruction.

Sequence of assembly

| Picture | Symbol | Sequence: | Torque: | Rotation angle: | Comments |
|---|---|------------|-------------|-----------------|---|
|  |  1 | | | | Observe installation position. |
|  |  3 | | | | Ensure that the piston rings are not damaged during assembly. |
|  |  2 | A, B | 6 ± 0.6 Nm | | Ensure accurate torque at all screws before next step. |
|  |  | A, B | | 70° +15° / -5° | Carry out the steps of this procedure one after the other |
|  |  5 | | 12 ± 1.2 Nm | | Ensure accurate torque at all screws before next step. |
|  |  2 | | | | Clean and press in oil-tight. Secure with Loctite 648 |
|  |  1 | A, B, C, D | 20 ± 2 Nm | | Ensure accurate torque at all screws before next step. |
|  |  | A, B, C, D | | 90° +10° / -5° | Carry out the steps of this procedure one after the other |
|  |  3 | | 100 ± 10 Nm | | Ensure accurate torque at all screws before next step. |
|  |  4 | | 32 ± 2 Nm | | |