

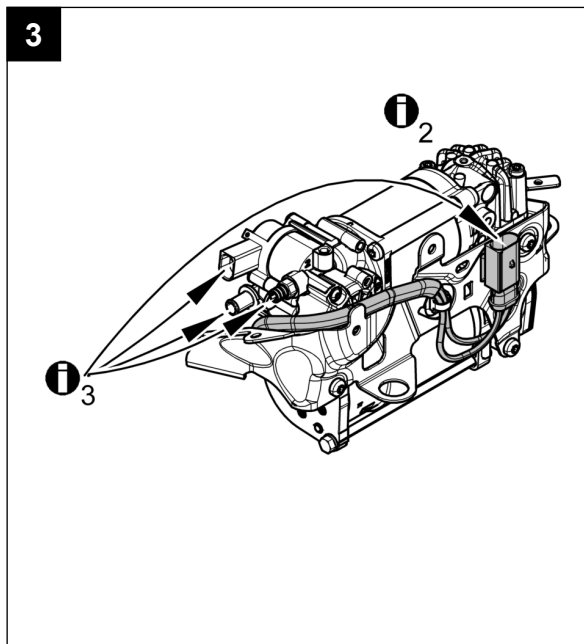

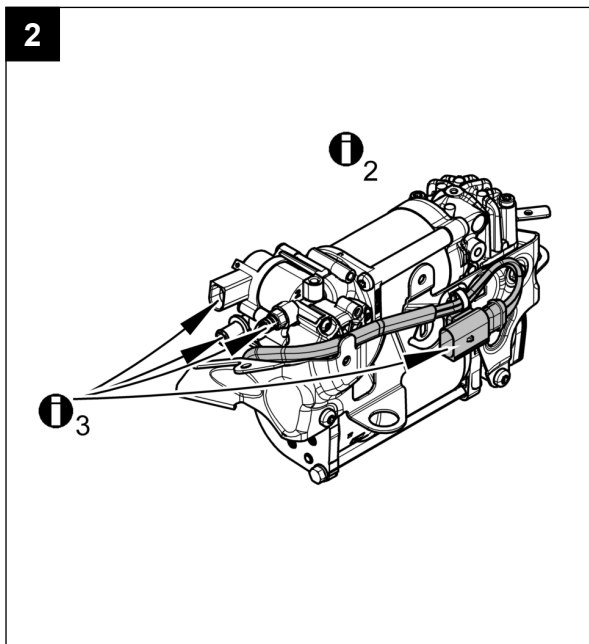

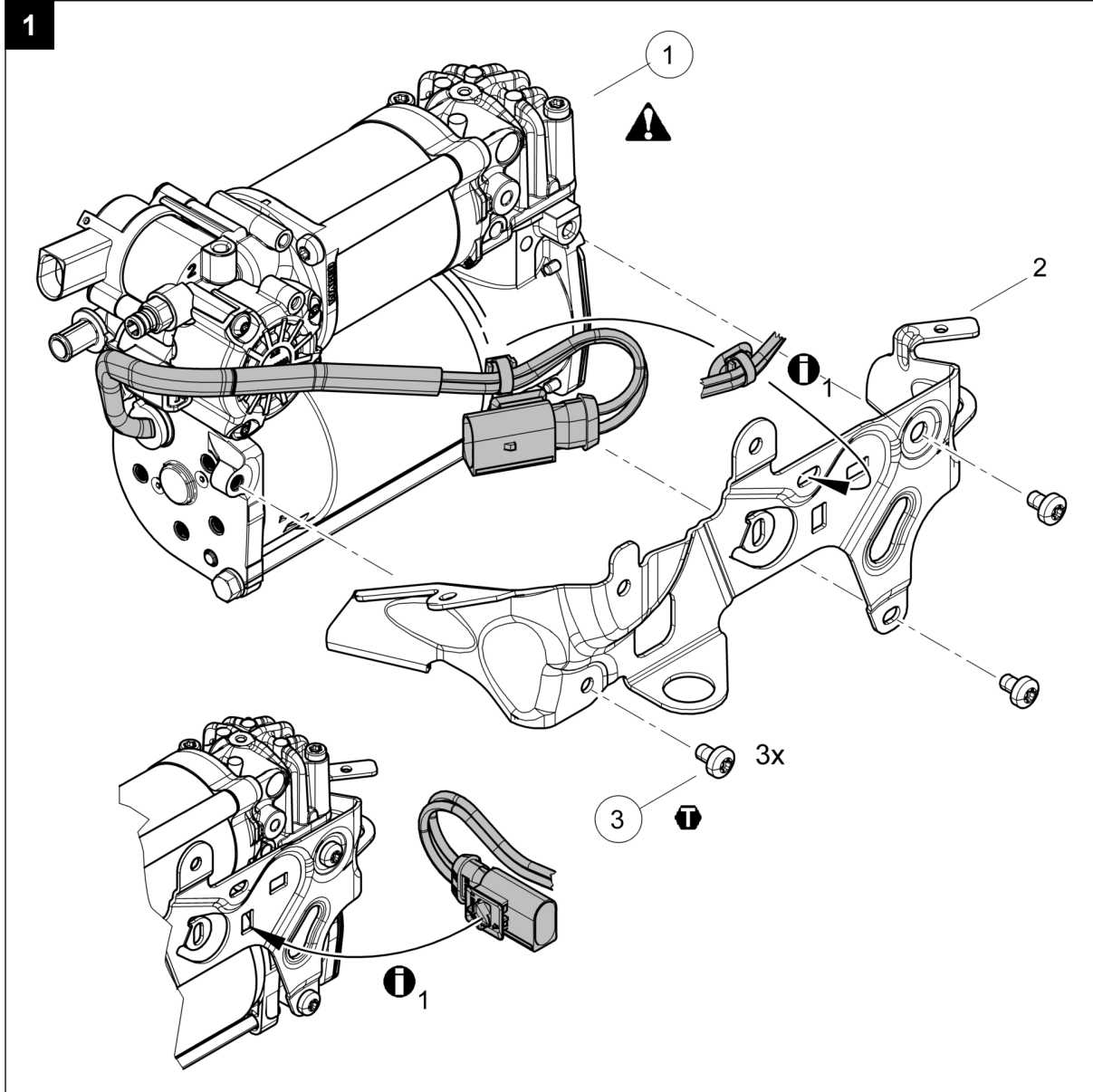





415 403 127 0  
415 403 128 0  
415 403 323 0



CS







## Signální slova a symboly

-  **DANGER** NEBEZPEČÍ Bezprostředně hrozící nebezpečí: těžká újma na zdraví nebo smrt
-  **WARNING** POZOR Možná nebezpečná situace: jako následek lehká nebo středně těžká újma na zdraví nebo poškození majetku
-  **CAUTION** VÝSTRAHA Možná nebezpečná situace: jako následek těžká újma na zdraví nebo smrt
-  Díly, které mají číslo pozice v kroužku, jsou obsažené v opravárenské sadě.

-  Instrukce / informace ke správnému provedení opravy
-  Opravárenskou sadu je možné použít pro přístroje uvedené v tabulce.
-  Prvek utáhněte uvedeným točivým momentem příp. pomocí kontroly úhlu natočení.





## Všeobecné pokyny k opravám



1. Opravárenské práce na přístrojích systému, který má vliv na bezpečnost vozidla, smí provádět pouze kvalifikovaný personál odborné servisní dílny.
3. Dodržujte předpisy BOZP podniku a národní předpisy.
5. S opravou začněte teprve tehdy, až všechny informace nutné pro opravu přečtete a porozumíte jim. Další potřebné dokumenty: zkušební postup, list náhradních dílů, všeobecné pokyny pro opravu a kontrolu (815 150 109 3) naleznete na internetových stránkách: [www.wabco-auto.com](http://www.wabco-auto.com), když v databázi INFORM zadáte produktové číslo přístroje nebo číslo dokumentu.
7. WABCO nepřebírá žádnou záruku za funkci nebo kvalitu opraveného přístroje.
9. Umístěte vozidlo na podstavnou stoliči.
2. Postupujte bezpodmínečně podle pokynů a instrukcí výrobce vozidla.
4. Používejte výhradně náhradní díly od firmy WABCO nebo díly schválené výrobcem vozidla.
6. Na adekvátním zařízení přezkoušejte – podle zkušebního postupu – každý opravený přístroj na funkčnost a těsnost.
8. Odpojte soustavu od elektrického napájení a zcela ji odzdušněte.

Obrázek	Symbol	Pozice	pro přístroje	Utahovací moment:	Poznámky
<b>1</b>		3		9 + 2 Nm	
		1			Nebezpečí popálení! Kompresor může být ještě horký z předchozí činnosti.
	 1				Dodržte místo montáže dílů a namontujte je opět do původní pozice.
<b>2</b>	 2		415 403 127 0		Správně provedená montáž
<b>2</b>	 3		415 403 127 0		Zkontrolujte, jestli jsou správně zapojena všechna pneumatická a elektrická vedení.
<b>3</b>	 2		415 403 128 0		Správně provedená montáž
<b>3</b>	 3		415 403 128 0		Zkontrolujte, jestli jsou správně zapojena všechna pneumatická a elektrická vedení.

de

## Signalwörter & Symbole

-  **DANGER** GEFAHR Unmittelbar drohende Gefährdung: Schwere Personenschäden oder Tod
-  **WARNING** VORSICHT Mögliche Gefahrensituation: Leichte oder mittelschwere Personenschäden oder Sachschäden als Folge
-  **CAUTION** WARNUNG Mögliche Gefahrensituation: Tod oder schwere Personenschäden als Folge
-  Teile mit Kreis um die Positionsnummer sind im Reparatursatz enthalten.

-  Anweisung / Information für eine korrekte Reparatur
-  Der Reparatursatz kann für Geräte entsprechend Tabelle verwendet werden.
-  Element mit angegebenen Drehmoment bzw. Drehwinkel anziehen.

de

## Allgemeine Reparaturhinweise

1. Reparaturarbeiten an Geräten eines Fahrzeug-Sicherheitssystems darf nur qualifiziertes Personal einer Fachwerkstatt durchführen.
2. Leisten Sie den Vorgaben und Anweisungen des Fahrzeugherstellers unbedingt Folge.
3. Halten Sie Unfallverhütungsvorschriften des Betriebes sowie nationale Vorschriften ein.
4. Verwenden Sie ausschließlich von WABCO oder vom Fahrzeughersteller freigegebene Ersatzteile.
5. Beginnen Sie die Reparatur erst dann, wenn Sie alle Informationen, die für die Reparatur notwendig sind, gelesen und verstanden haben. Zusätzlich benötigte Dokumente: Prüfanweisung, Ersatzteilblatt, Allgemeine Reparatur- und Prüfhinweise (815 020 109 3) zu finden auf [www.wabco-auto.com](http://www.wabco-auto.com) mittels Eingabe der Produktnummer des Gerätes bzw. Druckschriftennummer in INFORM.
6. Prüfen Sie jedes reparierte Gerät – gemäß Prüfanweisung – an einer adäquaten Einrichtung auf Funktionstüchtigkeit und Dichtigkeit.
7. WABCO übernimmt keinerlei Gewährleistung für die Funktion oder Qualität eines reparierten Gerätes
8. Machen Sie die Anlage stromlos und drucklos.
9. Setzen Sie das Fahrzeug auf Unterstellböcke.

Bild	Symbol	Position	für Geräte	Anzugsdrehmoment:	Bemerkungen
<b>1</b>		3		9 + 2 Nm	
		1			Verbrennungsgefahr! Der Kompressor kann noch warm sein von vorheriger Betätigung.
		1			Beachten Sie den Einbauort der Teile und montieren Sie sie wieder an der ursprünglichen Position.
<b>2</b>		2	415 403 127 0		Korrekt durchgeführte Montage
<b>2</b>		3	415 403 127 0		Prüfen Sie, ob alle pneumatischen und elektrischen Verbindungen hergestellt sind.
<b>3</b>		2	415 403 128 0		Korrekt durchgeführte Montage
<b>3</b>		3	415 403 128 0		Prüfen Sie, ob alle pneumatischen und elektrischen Verbindungen hergestellt sind.

en

## Symbols & Signal Words

- DANGER** Imminent hazard situation: serious personal injury or death as a result
- WARNING** Possible hazard situation: minor or moderate personal injury or material loss as a result
- CAUTION** Possible hazard situation: serious personal injury or death as a result
- Parts having item numbers with circles are included in the kit.

- Instruction / Information for a correct repair
- The kit can be used for devices according table.
- Tighten element with specified torque or angle of rotation.

## General Repair Hints

1. Only qualified personnel of a specialist workshop are authorized to perform repair work on a vehicle's security system.
2. Absolutely follow specifications and instructions of vehicle manufacturer.
3. Keep to company's relevant accident prevention regulations and national regulations.
4. Use only spare parts released by WABCO or vehicle manufacturer.
5. Always start repair work only when you have read and understood all information required for repair. Documents additionally needed: Test Instruction, Spare Parts List, General Repair and Test Hints (815 010 109 3) to be found on [www.wabco-auto.com](http://www.wabco-auto.com) by entering product number of the device or the publication number in INFORM.
6. Check each repaired equipment for functional efficiency and tightness on an adequate facility according to the test instruction.
7. WABCO does not accept any liability or responsibility for the quality or functionality of a repaired device
8. Make system electroless and pressureless.
9. Place vehicle on safety stands.

en

Picture	Symbol	Item	for devices	Torque:	Comments
<b>1</b>		3		9 + 2 Nm	
		1			Burn hazard! The compressor could be hot from previous operation.
		1			Observe installation position of all parts and reassemble to origin place
<b>2</b>		2	415 403 127 0		Correct Assembly
<b>2</b>		3	415 403 127 0		Check that all the pneumatic and electrical connections are made.
<b>3</b>		2	415 403 128 0		Correct Assembly
<b>3</b>		3	415 403 128 0		Check that all the pneumatic and electrical connections are made.

es

## Símbolos & Palabras de aviso

- DANGER** PELIGRO Situación de peligro inminente: Pueden ocasionarse daños personales graves o incluso mortales
- WARNING** CUIDADO Posible situación de peligro: Pueden ocasionarse daños personales leves o moderados o pérdidas materiales
- CAUTION** ADVERTENCIA Posible situación de peligro: Pueden ocasionarse daños personales graves o incluso mortales
- Los componentes incluidos en el kit son los números que aparecen con círculo.

- Instrucciones/Información para una correcta reparación
- El kit puede ser utilizado en los equipos que aparecen en la tabla.
- Apretar el elemento con el par de apriete o ángulo de giro indicado.





## Consejos generales de reparación



1. Sólo el personal cualificado de un taller especializado está autorizado para realizar las tareas de reparación en los sistemas de seguridad de los vehículos.
3. Siga las regulaciones y normas acerca de prevención de riesgos laborales de su empresa y de su país.
5. Comience la reparación sólo cuando haya leído y comprendido las instrucciones de reparación. Documentos adicionales necesarios: Instrucciones de comprobación, listas de despiece, consejos generales de comprobación y reparación (815 040 109 3), los cuales pueden encontrarse en [www.wabco-auto.com](http://www.wabco-auto.com), introduciendo la referencia del aparato o la referencia de la publicación en la aplicación INFORM.
7. WABCO no asume garantía alguna por el funcionamiento o calidad de un equipo reparado.
9. Coloque el vehículo sobre soportes de seguridad.
2. Atenerse exactamente a las indicaciones e instrucciones del fabricante del vehículo.
4. Utilice piezas de repuesto suministradas por WABCO o el fabricante del vehículo.
6. Compruebe la eficacia de funcionamiento y de ajuste de cada equipo reparado en unas instalaciones adecuadas según las instrucciones de comprobación.
8. Disminuya la presión del sistema.

Dibujos	Símbolos	Posición	para aparatos	Par de apriete:	Observaciones
<b>1</b>		3		9 + 2 Nm	
		1			¡Peligro de quemaduras! El compresor puede estar todavía caliente debido al funcionamiento anterior.
		1			Observar el lugar de montaje de las piezas y volver a montarlas en su posición original.
<b>2</b>		2	415 403 127 0		Montaje correcto
<b>2</b>		3	415 403 127 0		Compruebe que se han realizado todas las conexiones neumáticas y eléctricas.
<b>3</b>		2	415 403 128 0		Montaje correcto
<b>3</b>		3	415 403 128 0		Compruebe que se han realizado todas las conexiones neumáticas y eléctricas.

fr













## Symboles & Significations

-  **DANGER** DANGER Situation de danger imminent : Danger de mort ou de dommage corporel sérieux.
-  **WARNING** ATTENTION Situation de danger probable : Risque de dommage corporel mineur ou modéré ou perte de matériel.
-  **CAUTION** AVERTISSEMENT Situation de danger de danger probable : Danger de mort ou de dommages corporel sérieux
-  Les composants avec repères entourés sont inclus dans le kit.

-  Instruction/Information pour une réparation correcte
-  Le kit peut être utilisé pour les appareils indiqués sur le Feuille.
-  Serrer l'élément avec le couple et la position angulaire indiqués.





## Conseils généraux de réparation



1. Uniquement le personnel qualifié d'un atelier agréé WABCO est autorisé à effectuer la réparation sur les systèmes de sécurité d'un véhicule.
3. Veillez aux règlements de prévention des accidents indiqués par votre société et aux règlements nationaux.
5. Commencez toujours le travail de réparation seulement après avoir lu et compris toutes les informations indiquées pour la réparation. Documentation complémentaire nécessaire : Instruction d'essai, liste des pièces détachées, instructions de réparation et conseils d'essai (815 030 109 3) en tapant la référence du produit ou le numéro de la publication dans INFORM sur internet : [www.wabco-auto.com](http://www.wabco-auto.com)
7. WABCO n'assume aucune garantie quant au fonctionnement ou à la qualité d'un appareil réparé.
9. Placez le véhicule sur des stands de sécurité.
2. Respecter toujours les prescriptions et instructions du constructeur du véhicule.
4. Employez seulement les pièces de rechange WABCO ou du constructeur du véhicule.
6. Examinez chaque appareil réparé pour s'assurer de l'efficacité fonctionnelle et de l'étanchéité selon l'instruction d'essai.
8. Mettre le system hors électricité et hors pression.

Image	Symbole	Position	pour appareils	Couple de serrage:	Remarques
		3		9 + 2 Nm	
		1			Risque de brûlure ! Le compresseur peut encore être chaud s'il vient d'être actionné.
	 1				Faire attention à l'endroit où sont installées les pièces et bien les remonter en position initiale.
	 2		415 403 127 0		Assemblage correct
	 3		415 403 127 0		Vérifier que toutes les connexions électriques et pneumatiques sont faites.
	 2		415 403 128 0		Assemblage correct
	 3		415 403 128 0		Vérifier que toutes les connexions électriques et pneumatiques sont faites.

hr

## Simboli & Značenja

-  **DANGER** OPREZ Neposredna rizična situacija: moguće ozbiljno ozljeđivanje ili smrt
-  **WARNING** OPASNOST neposredna rizična situacija: moguće manje ozljeđivanje materijalna šteta
-  **CAUTION** UPOZORENJE Neposredna rizična situacija: moguće ozbiljno ozljeđivanje ili smrt
-  Dijelovi uređaja čiji su brojevi zaokruženi nalaze se u kompletu..

-  Informacija o ispravnom popravku.
-  Set može biti korišten za uređaje prema tabeli.
-  Zategnite element primjenom navedenog zakretnog momenta ili zakretnog kuta.

hr

## Opće upute o popravcima

1. Samo kvalificirane osobe istručnjaci smiju popravljati siguronosne sustave na vozilu.
3. Provodi tvrtkine siguronosne propise kao i nacionalne propise o sigurnosti
5. Popravak počni tek nakon što pročitaš i shvatiš upute o popravku. Potrebni dokumenti: Instrukcije o testiranju, Lista rezervnih dijelova, Opće natuknice o popravku i testiranju (815 010 109 3) mogu se naći na [www.wabco-auto.com](http://www.wabco-auto.com) nakon upisa kataložskog broja proizvoda ili publikacije u INFORM-u.
7. WABCO ne preuzima odgovornost za rad i kvalitetu popravljenog uređaja.
9. Postavi vozilo na siguronosno postolje.
2. U potpunosti slijedi specifikacije i upute proizvođača vozila.
4. Koristi rezervne dijelove proizvedene od WABCA ili proizvođača vozila..
6. Provjeri svaki popravljeni uređaj kako radi i da li je zategnuto sve kako treba prema odgovarajućim uputama o testiranju proizvoda.
8. Oslobodi sustav od napona i pritiska.

Slika	Simbol	Pojedinost	za uređaj	Zakretni moment:	Komentar
<b>1</b>		3		9 + 2 Nm	
		1			Opasnost od opekline! Kompresor može još uvijek biti topao nakon prethodnog pokretanja.
		1			Uzmite u obzir mjesto ugradnje dijelova i ponovno ih ugradite u početni položaj.
<b>2</b>		2	415 403 127 0		Ispravan način ugradnje
<b>2</b>		3	415 403 127 0		Provjeri da li su spojeni svi električni i zračni priključci.
<b>3</b>		2	415 403 128 0		Ispravan način ugradnje
<b>3</b>		3	415 403 128 0		Provjeri da li su spojeni svi električni i zračni priključci.

it

## Simboli e Segnali

- DANGER** PERICOLO Imminente situazione di rischio: serie ferite personali fino anche alle morte
- WARNING** PRUDENZA Possibili situazioni di pericolo: possibili lievi ferite o perdita di materiale
- CAUTION** AVVERTENZA Possibili situazioni di pericolo: serie ferite personali fino anche alle morte
- I componenti indicati con un numero cerchiato, sono inclusi nel kit.

- Istruzioni/Informazioni per un'accurata riparazione
- Il kit può essere usato per gli articoli secondo la tabella.
- Serrare l'elemento con la coppia/angolo di rotazione indicati.

## Suggerimenti per la riparazione

1. Soltanto il personale qualificato delle officine specializzate è autorizzato ad effettuare le riparazioni sui sistemi di sicurezza dei veicoli.
3. Attenersi alle norme nazionali e aziendali in merito alla prevenzione degli infortuni.
5. Effettuare la riparazione solamente dopo aver letto e capito tutte le informazioni richieste per la riparazione. Ulteriori informazioni necessarie: istruzioni di collaudo, catalogo dei ricambi, cenni generali sulla riparazione e test (815 050 109 3) possono essere trovati sul sito [www.wabco-auto.com](http://www.wabco-auto.com) alla voce INFORM entrando per codice dell'apparecchio o per numero della pubblicazione.
7. WABCO non si assume alcuna responsabilità per il funzionamento o la qualità di un apparecchio riparato.
9. Mettere in sicurezza il veicolo tale che non si muova.
2. E' assolutamente necessario seguire le istruzioni e le specifiche del costruttore del veicolo.
4. Usare solo ricambi originali WABCO o del costruttore del veicolo.
6. Controllare la funzionalità e l'efficienza di ogni apparecchiatura riparata secondo le istruzioni riportate nel manuale di collaudo.
8. Fare in modo che il sistema sia privo da scariche elettriche e pressioni residue.

it

Figura	Simbolo	Particol- are	per apparecchi	Coppia di serraggio:	Note
<b>1</b>		3		9 + 2 Nm	
		1			Pericolo di ustioni! Il compressore può ancora essere caldo dal precedente utilizzo.
		1			Osservare la posizione di montaggio dei componenti e rimontarli nella posizione originale.
<b>2</b>			415 403 127 0		Montaggio Corretto
<b>2</b>			415 403 127 0		Controllare che tutte le connessioni pneumatiche ed elettriche siano state effettuate.
<b>3</b>			415 403 128 0		Montaggio Corretto
<b>3</b>			415 403 128 0		Controllare che tutte le connessioni pneumatiche ed elettriche siano state effettuate.

pl

## Hasła ostrzegawcze i symbole

- DANGER** NIEBEZPIECZEŃSTWO Bezpośrednie zagrożenie ciężkimi obrażeniami bądź śmiercią.
- WARNING** UWAGA! Niebezpieczeństwo grożące lekkimi bądź średnimi obrażeniami.
- CAUTION** OSTRZEŻENIE Niebezpieczeństwo grożące śmiercią bądź ciężkimi obrażeniami.
- Części oznaczone kółkiem wokół numeru pozycji należą do zestawu naprawczego.

Wskazówki / Informacje dotyczące poprawnej naprawy.

Zestaw naprawczy może być używany do urządzeń według tabeli.

Dokręcić element podanym momentem obrotowym.



## Ogólne porady naprawcze



1. Prace naprawcze w obrębie urządzeń układu bezpieczeństwa pojazdu mogą być wykonane jedynie przez wykwalifikowany personel specjalistycznego warsztatu.
3. Należy przestrzegać zakładowych i krajowych przepisów BHP.
5. Naprawę należy rozpocząć dopiero wówczas, gdy wszystkie potrzebne do niej informacje zostaną przeczytane i zrozumiane. Dokumenty potrzebne dodatkowo: instrukcja kontrolna, tabela części zamiennych, ogólne wskazówki dotyczące naprawy i kontroli (815 020 109 3) znajdują Państwo na stronie internetowej [www.wabco-auto.com](http://www.wabco-auto.com), podając numer urządzenia bądź numer publikacji w bazie INFORM.
7. WABCO nie udziela żadnej gwarancji na działanie lub jakość naprawionego urządzenia.
9. Umieść pojazd na bezpiecznym miejscu.
2. Należy koniecznie postępować według wytycznych i wskazówek producenta pojazdu.
4. Należy używać wyłącznie części zamiennych dopuszczonych przez firmę WABCO bądź przez producenta pojazdu.
6. Na odpowiednim urządzeniu należy sprawdzić każde naprawiane urządzenie - zgodnie z instrukcją kontrolną - pod kątem sprawności działania i szczelności.
8. Odłącz napięcie i spuść powietrze z systemu.

Obraz	Symbol	Pozycja	do urządzeń	Moment dokręcania:	Komentarz
<b>1</b>		3		9 + 2 Nm	
		1			Niebezpieczeństwo poparzenia. Sprężarka może być jeszcze gorąca po poprzedniej pracy.
		1			Należy zwrócić uwagę na miejsce montażu części i zamontować je ponownie w ich pierwotnej pozycji.
<b>2</b>			415 403 127 0		Prawidłowe złożenie
<b>2</b>			415 403 127 0		Sprawdź czy wszystkie połączenia elektryczne i pneumatyczne są podłączone.
<b>3</b>			415 403 128 0		Prawidłowe złożenie
<b>3</b>			415 403 128 0		Sprawdź czy wszystkie połączenia elektryczne i pneumatyczne są podłączone.

ru













## Знаки & символы

-  **DANGER** ОПАСНО Прямая угроза аварийной ситуации: влечет за собой смерть или тяжелые повреждения
-  **WARNING** ОСТОРОЖНО Опасная ситуация: последствиями являются легкие повреждения или повреждения средней тяжести, а также материальный ущерб
-  **CAUTION** ПРЕДУПРЕЖДЕНИЕ Опасная ситуация: влечет за собой смерть или тяжелые повреждения
- Номера частей, обведенные кружком, Вы найдете в ремкомплекте.



-  Указание/информация для проведения надлежащего ремонта
-  Ремкомплект может быть использован для приборов соответственно таблице.
-  Затянуть элемент с заданным моментом затяжки или на заданный угол поворота.



## Общие указания по ремонту

1. Провождение ремонта приборов данной системы должно производиться только квалифицированным персоналом в специализированной мастерской.
3. Соблюдайте предписания предприятия по технике безопасности, а также национальные нормы.
5. Проводите ремонт только после того, как вы прочитали и поняли все информации, необходимые для данного процесса. Дополнительные документы: инструкция по тестированию, список запасных частей, общие инструкции по ремонту и проведению испытаний (815 080 109 3) Вы найдете на [www.wabco-auto.com](http://www.wabco-auto.com). Для этого необходимо задать номер нужного прибора или номер брошюры в INFORM.
7. Компания WABCO не принимает на себя какую-либо ответственность за работу или качество отремонтированных устройств.
9. Разместите автомобиль на безопасном стенде.
2. Следуйте предписаниям и инструкциям изготовителя транспортного средства.
4. Используйте только запчасти, допущенные к использованию компанией Wabco или производителем транспортного средства.
6. Проконтролируйте каждый отремонтированный прибор- согласно инструкции по тестированию- на работоспособность и герметичность с помощью соответствующего оборудования.
8. Обесточьте электросистему и спустите давление.

Изображение	Символ	Позиция	для приборов	Момент сопротивления:	Замечания
		3		9 + 2 Nm	
		1			Опасность получения ожога! Компрессор может быть еще горячим в результате предыдущего включения.
	 1				Учитывайте место установки детали и установите ее назад в первоначальном положении.
	 2		415 403 127 0		Правильная сборка.
	 3		415 403 127 0		Проверьте правильность соединения всех пневматических и электрических соединений.
	 2		415 403 128 0		Правильная сборка.
	 3		415 403 128 0		Проверьте правильность соединения всех пневматических и электрических соединений.

zh

-  **DANGER** 危险! 直接危险: 导致个人严重伤害或死亡
-  **WARNING** 小心! 可能危险: 导致较小或一般程度人员伤害或物品损失
-  **CAUTION** 警告! 可能危险: 导致个人严重伤害或死亡
- 修包中包含号码带有圆圈的零件。

-  用于正确维修的指导与信息。
-  根据表格所示, 修包可以用于相应的总成维修。
-  用给定的扭矩及转角上紧元件。



1. 仅在专业维修店的有资质的人员被授权执行车辆安全系统的维修工作。
2. 完全遵循车辆制造商的规格和安装指导。
3. 遵循公司的相关事故预防条例和国家法规。
4. 仅使用于由威伯科公司或整车制造商发布的备件产品。
5. 当你已经阅读并已理解维修所需要的所有信息后，才能开始维修工作。此外需要的信息：试验指导，备件清单，通用维修和试验提示（815 010 109 3）可以在www.wabco-auto.com 找到。只需在其上键入产品号码或INFORM中的出版物号码。
6. 根据试验要求在适当的设备上，检测每个维修设备的功效和紧密性。
7. WABCO对经过修理的设备的功能或质量不承担任何责任。
8. 确保系统无电无压。
9. 请将车辆放置到支架上。

图片	符号	零件	用于产品	扭矩:	注释
		3		9 + 2 Nm	
		1			烫伤危险！压缩机因先前开动过可能还很烫。
		1			请注意部件的安装位置，请将其安装到原先的位置上。
			415 403 127 0		正确进行的装配
			415 403 127 0		检查所有的气路和电子的连接。
			415 403 128 0		正确进行的装配
			415 403 128 0		检查所有的气路和电子的连接。

## Semboller&amp;belirti sözleri

- DANGER** TEHLİKE Tehlikeli durum: ciddi personel yaralanması veya ölüm riski.
- WARNING** DİKKAT Tehlike riski: hafif personel yaralanması veya maddi zarar.
- CAUTION** UYARI Ciddi personel yaralanması veya ölüm riski.
- Yuvarlak içinde numarası belirtilen parça numaraları kit içerisinde bulunur.

- Talimat/ Doğru tamir için bilgi
- Tabloda belirtilen parçalar için kit kullanılabilir.
- Elemanı belirtilen sıkma torku ya da dönme açısı ile sıkın.

## Genel tamir bilgisi

1. Araçların güvenlik sistemlerinde tamir işlemlerini yalnızca eğitim almış konusunda uzman personeller gerçekleştirebilir.
2. Araç üretici firma özellikler ve talimatlarına kesinlikle uyunuz.
3. Şirket emniyet kuralları ve ulusal regülasyonlarına uyunuz.
4. Sadece WABCO veya üretici firma tarafından yayınlanan yedek parçaları kullanın.
5. Tamire, tamir işlemi için gerekli olan tüm bilgileri okuyup anladıktan sonra başlayınız. Ayrıca gerekli olan dokümanlar: Test talimatı, yedek parça sayfası, genel tamir ve test bilgileri (815 140 109 3). Tümünü linki altında, online ürün kataloğu INFORM'da cihaza ait ürün numarasını veya baskı numarasını girerek bulabilirsiniz.
6. Tamir edilmiş her cihazı - test talimatına uygun şekilde - uygun bir donanımla işlevsellik ve sızdırmazlık konusunda kontrol edin.
7. WABCO tamir edilmiş bir cihazın işlevselliği veya kalitesi için hiçbir sorumluluk üstlenmemektedir.
8. Sistemi akımsız ve basınçsız duruma getirin.
9. Artacı güvenli bir yere çıkarın.

tr

Resim	Sembol	Parça	Cihazlar için	Tork:	Yorumlar
<b>1</b>		3		9 + 2 Nm	
		1			Yanma tehlikesi! Kompresör önceki çalışmadan dolayı halen sıcak olabilir.
		1			Parçaların montaj yerine dikkat edin ve onları tekrar asıl konumlarına monte edin.
<b>2</b>		2	415 403 127 0		Doğru Montaj
<b>2</b>		3	415 403 127 0		Tüm pnomatik ve elektriksel bağlantıların gerçekleştirildiğini kontrol edin.
<b>3</b>		2	415 403 128 0		Doğru Montaj
<b>3</b>		3	415 403 128 0		Tüm pnomatik ve elektriksel bağlantıların gerçekleştirildiğini kontrol edin.

pt

### Símbolos e Significados

- DANGER** Perigo! Risco de acidente iminente: lesão corporal grave e/ou risco de morte.
- WARNING** Cuidado! Possível situação de acidente: ferimentos leves/moderados e/ou danos materiais.
- CAUTION** Atenção! Possível situação de acidente: lesão corporal grave e/ou risco de morte.
- Componentes que estão marcados com um círculo compõem o jogo de reparo.

- Instrução/Informação para uma correta reparação.
- O jogo de reparo pode ser utilizado nos produtos relacionados na tabela.
- Apertar o elemento com o binário ou o ângulo de rotação indicado.





### Dicas Gerais para Reparação



- Por motivo de segurança, somente pessoas qualificadas devem efetuar reparação nos sistemas de freio do veículo.
- Mantenha e siga as orientações de prevenção de acidentes vigentes e/ou impostas pelos órgãos competentes.
- Somente inicie o trabalho de reparação após ler e entender todas as informações necessárias para realizar uma reparação. Documentos adicionais necessários: instrução de teste, lista de peças sobressalentes, dicas gerais de testes e reparação (815 130 109 3) podem ser encontrados no site [www.wabco-auto.com](http://www.wabco-auto.com) ao inserir o número do produto.
- A WABCO não assume qualquer responsabilidade pela função ou qualidade de um equipamento reparado.
- Posicionar o veículo nos cavaletes com segurança.
- Siga sempre as recomendações/especificações do fabricante do veículo.
- Use somente peças de reposição aprovadas pela WABCO ou pelo fabricante do veículo.
- Verificar cada produto reparado conforme instruções de teste, utilizando os equipamentos necessários e local adequado.
- Realizar a manutenção do veículo com o sistema elétrico desligado e o sistema pneumático despressurizado.

Figura	Símbolo	Item	Para conjuntos	Torque:	Comentários
<b>1</b>		3		9 + 2 Nm	
		1			Perigo de queimaduras! O compressor ainda pode estar quente, devido à sua utilização anterior.
		1			Tenha em atenção o local de montagem das peças e monte-as novamente na posição original.
<b>2</b>		2	415 403 127 0		Montagem correta
<b>2</b>		3	415 403 127 0		Verifique se estão estabelecidas todas as conexões pneumáticas e elétricas.
<b>3</b>		2	415 403 128 0		Montagem correta
<b>3</b>		3	415 403 128 0		Verifique se estão estabelecidas todas as conexões pneumáticas e elétricas.

ro













## Simboluri și cuvinte pentru avertizare

-  **DANGER** Situație de pericol iminentă: poate rezulta vătămare corporală gravă sau deces.
-  **WARNING** Posibilă situație de pericol: pot rezulta vătămări corporale minore sau medii sau pagube materiale
-  **CAUTION** Posibilă situație de pericol: poate rezulta vătămare corporală gravă sau deces
-  Piesele cu numărul de articol încercuit sunt incluse în kit.

-  Instrucțiuni / Informare pentru o reparare corectă
-  Kitul poate fi folosit pentru dispozitive, conform tabelului.
-  Strângeți elementul cu cuplul, respectiv unghiul de rotire indicat.





## Instrucțiuni generale referitoare la reparație



1. Numai personalul calificat al unui atelier de service specializat este autorizat să efectueze lucrări de reparații pe sistemul de siguranță al vehiculului.
3. Respectați prevederile firmei și cele naționale pentru prevenirea accidentelor.
5. Întotdeauna începeți lucrările de reparații numai după ce ați citit și înțeles toate informațiile necesare pentru reparație. Documente suplimentare necesare: Instrucțiuni de testare, Lista pieselor de schimb, Instrucțiuni generale pentru reparare și testare (815 110 109 3) pot fi găsite pe [www.wabco-auto.com](http://www.wabco-auto.com) introducând codul dispozitivului în INFORM.
7. WABCO nu garantează sau nu răspunde pentru funcționarea și calitatea unui dispozitiv reparat.
9. Plasați vehiculul pe un loc sigur.
2. Respectați obligatoriu instrucțiunile date de producătorul vehiculului.
4. Utilizați exclusiv piese de schimb autorizate de WABCO sau de producătorul autovehiculului.
6. Verifică eficiența funcțională și etanșeitatea fiecărui echipament reparat pe o instalație adecvată în conformitate cu instrucțiunile de testare.
8. Oprii alimentarea sistemului cu tensiune și goliți presiunea.

Imagine	Simbol	Articol	pentru dispozitive	Moment de torsiune:	Comentarii
		3		9 + 2 Nm	
		1			Pericol de arsuri! Compresorul poate fi cald ca urmare a unei acționări anterioare.
		1			Respectați locul de montare al pieselor și montați-le din nou la poziția inițială.
		2	415 403 127 0		Asamblare corectă
		3	415 403 127 0		Verificați dacă toate conexiunile electrice și pneumatice sunt făcute.
		2	415 403 128 0		Asamblare corectă
		3	415 403 128 0		Verificați dacă toate conexiunile electrice și pneumatice sunt făcute.

ko







## Symbols & Signal Words

-  **DANGER** 급박한 위험 상황: 심각한 상해 또는 사망에 이르게 할 수 있습니다.
-  **WARNING** 잠재적 위험 상황: 경미하거나 완화된 부상 또는 물질적 손실을 입을 수 있습니다.
-  **CAUTION** 잠재적 위험 상황: 심각한 상해 또는 사망에 이르게 할 수 있습니다.
-  본 키트에는 원숫자로 표기된 제품들만 포함되어 있습니다.

-  올바른 수리를 위한 설명 / 정보
-  표를 참조하여 제품에 대한 키트를 사용할 수 있습니다.
-  제시된 토크 및 회전각으로 요소를 조이십시오.

ko

1. 자격이 있는 전문 정비사만이 차량의 안전 시스템을 수리하실 수 있습니다.
2. 꼭 차량제조사사의 사양과 지침서를 따르십시오.
3. 회사의 사고예방 규제와 국내 법적 규제를 지키십시오.
4. 와브코 또는 차량 제조사로부터 제공된 예비부품만을 사용하십시오.
5. 항상 수리에 필요한 모든 정보를 읽고 이해했을 때만 작업을 시작하십시오. 추가적으로 필요한 간행물: 검사지침, 예비부품 리스트, 일반적인 수리 및 검사 참고사항 (815 010 109 3)은 와브코 홈페이지 [www.wabco-auto.com](http://www.wabco-auto.com)의 INFORM으로 들어가셔서 제품번호 또는 간행물 번호를 조회하여 찾으실 수 있습니다.
6. 기능적 효율과 견고함을 위해 검사지침에 따라 각 수리장비들을 적절한 설비위에서 체크해 보시기 바랍니다.
7. 와브코는 수리된 제품의 품질과 기능에 대해 어떠한 책임도 지지 않습니다.
8. 시스템의 전원과 압력을 제거해 주십시오.
9. 차량을 안전한곳에 세워 두십시오.

그림	기호	품목	제품에 한함.	토크:	주석
<b>1</b>		3		9 + 2 Nm	
		1			화상 위험! 컴프레서는 이전 작동으로 인해 뜨거운 상태일 수 있습니다.
	 1				모든 부품의 장착위치를 준수하시고 원래 위치로 재조립 하십시오.
<b>2</b>	 2		415 403 127 0		올바른 조립
<b>2</b>	 3		415 403 127 0		공압라인 및 전기가 연결되었는지 확인하십시오.
<b>3</b>	 2		415 403 128 0		올바른 조립
<b>3</b>	 3		415 403 128 0		공압라인 및 전기가 연결되었는지 확인하십시오.