

Non e permesso consegnare a terzi o riprodurre questo documento, ne utilizzarne il contenuto o renderlo comunque noto a terzi senza autorizzazione esplicita. Ogni infrazione costituirà un evidente abuso e comporterà il risarcimento dei danni subiti. E' fatta riserva di tutti i diritti derivanti da brevetti o modelli.

Copying of this document and giving it to others and the use or communication of the contents thereof, are forbidden without express authority. Contravention of this restriction will constitute an evident abuse and result in a liability to the payment of damages. All rights are reserved in the event of the grant of patent or registration of a utility model or design. This document is the subject of copyright.

Toute communication ou reproduction de ce document, toute exploitation ou communication de son contenu sont interdites, sauf autorisation expresse. Tout manquement a cette regle constitue un abus evident et expose son auteur au versement de dommages et interets. Tous droits de propriete industrielle reserves, notamment en matiere de brevets et de modeles.

Weitergabe sowie Vervielfaeltigung dieser Unterlage, Verwertung und Mitteilung ihres Inhalts nicht gestattet, soweit nicht ausdrucklich zugestanden. Zuwiderhandlungen stellen einen offensichtlichen Missbrauch dar und verpflichten zu Schadenersatz. Alle Rechte ruer den Fall der Patentierung oder Gebrauchsmuster-Eintragung vorbehalten.

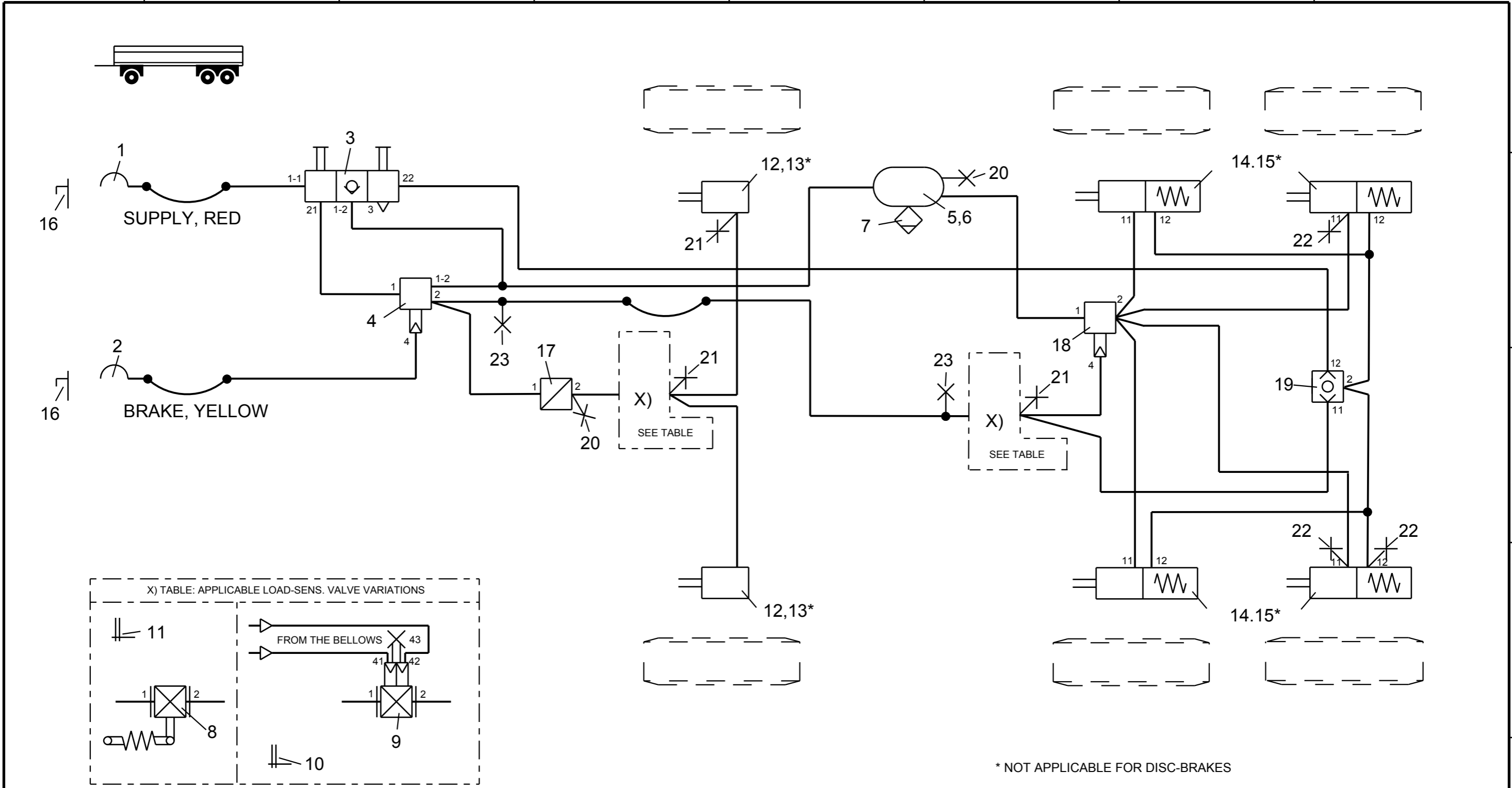

12	2	BRAKE CHAMBER	423 0	24			
11	1	TAG "SETTING VALUE OF LSV" MECH.	X) 899 144 630 4	23	2	TEST CONNECTION 463 703 ... 0	
10	1	TAG "SETTING VALUE OF LSV" AIR	X) 899 144 631 4	22	3	TEST CONNECTION 463 703 036 0	
9	2	LOAD-SENS.V. W. INTEGR. TEST VALVE	X) 475 714 50. 0	21	3	TEST CONNECTION 463 703 120 0	
8	2	LOAD-SENS.V. W. INTEGR. FLEX ARM	X) 475 713 50. 0	20	2	TEST CONNECTION 463 703 115 0	
7	1	DRAIN VALVE	934 300 001 0	19	1	TWO WAY-VALVE 434 208 055 0	
6	2	HOSE CLAMP	451 999 ... 2	18	1	RELAY VALVE 973 011 0.. 0	
5	1	AIR RESERVOIR	950 0	17	1	PRESS. LIMIT. VALVE 975 00. 0.. 0	
4	1	TRAILER-BRAKE VALVE	971 002 ... 0	16	2	DUMMY COUPLING WITH FIXTURE 452 402 000 0	
3	1	DOUBLE RELEASE VALVE	963 001 051 0	15	4	KIT 423 903 532 2	
2	1	COUPLING HEAD W.INT.LINE FILTER	952 201 003 0	14	4	TRISTOP BRAKE ACTUATOR 925 0	
1	1	COUPLING HEAD W.INT.LINE FILTER	952 201 004 0	13	2	KIT 423 ... 53. 2	
Pos.	Pcs.	Denomination	Product Identification No.	Pos.	Pcs.	Denomination	Product Identification No.

Copyright WABCO®

WABCO

TWO LINE-AIR BRAKING SYSTEM
FOR 3-AXLES-TRAILER
2xLOAD-SENS. VALVE, OPTION MECH./AIR

Date	Signature				
2013-06-18	BURMESTER				
2013-06-18	CHRONIS				
Expert					
BURMESTER					
Mass	Scale	Material No.	Date of first issue:2013-06-18		
KG		841 601 135 0	Doc.Code	Language	Sheet
Size	CAD System		002	EN	1/1
A 3	Pro/E	ECN-No.	Revision	Techn. Resp.	Replacement for
				4990	