

Non e permesso consegnare a terzi o riprodurre questo documento, ne utilizzarne il contenuto o renderlo comunque noto a terzi senza autorizzazione esplicita. Ogni infrazione costituirà un evidente abuso e comporterà il risarcimento dei danni subiti. E' fatta riserva di tutti i diritti derivanti da brevetti o modelli.

Copying of this document and giving it to others and the use or communication of the contents thereof, are forbidden without express authority. Contravention of this restriction will constitute an evident abuse and result in a liability to the payment of damages. All rights are reserved in the event of the grant of patent or registration of a utility model or design. This document is the subject of copyright.

Toute communication ou reproduction de ce document, toute exploitation ou communication de son contenu sont interdites, sauf autorisation expresse. Tout manquement a cette regle constitue un abus evident et expose son auteur au versement de dommages et interets. Tous droits de propriete industrielle reserves, notamment en matiere de brevets et de modeles.

Weitergabe sowie Vervielfaeltigung dieser Unterlage, Verwertung und Mitteilung ihres Inhalts nicht gestattet, soweit nicht ausdruecklich zugestanden. Zuwiderhandlungen stellen einen offensichtlichen Missbrauch dar und verpflichten zu Schadenersatz. Alle Rechte ruer den Fall der Patentierung oder Gebrauchsmuster-Eintragung vorbehalten.

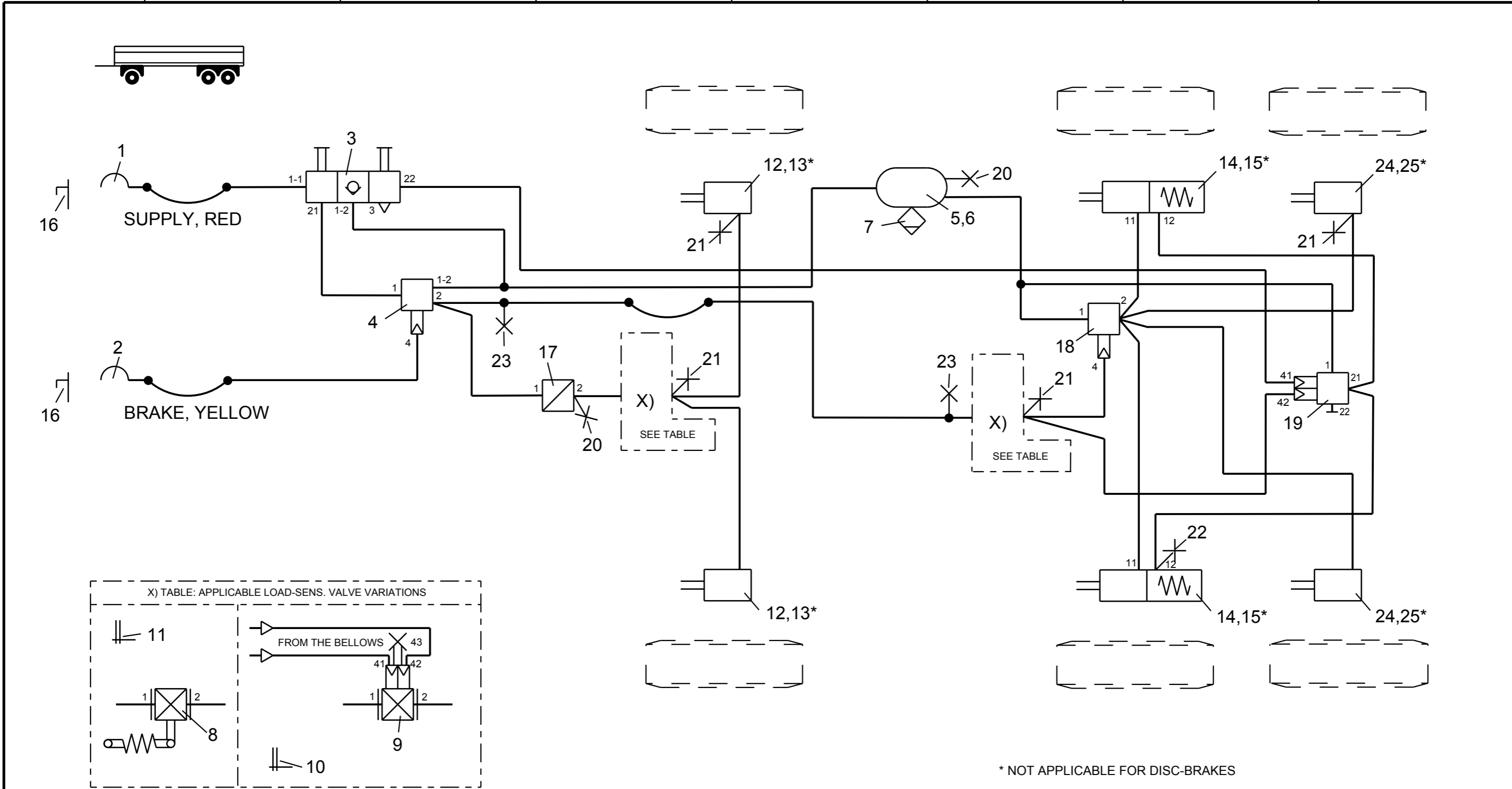

12	2	BRAKE CHAMBER		423 0	25	2	KIT		423 ... 53. 0
11	1	TAG "SETTING VALUE OF LSV" MECH.	X)	899 144 630 4	24	2	BRAKE CHAMBER		423 0
10	1	TAG "SETTING VALUE OF LSV" AIR	X)	899 144 631 4	23	2	TEST CONNECTION		463 703 ... 0
9	2	LOAD-SENS.V. W. INTEGR. TEST VALVE	X)	475 714 50. 0	22	1	TEST CONNECTION		463 703 036 0
8	2	LOAD-SENS.V. W. INTEGR. FLEX ARM	X)	475 713 50. 0	21	4	TEST CONNECTION		463 703 120 0
7	1	DRAIN VALVE		934 300 001 0	20	2	TEST CONNECTION		463 703 115 0
6	2	HOSE CLAMP		451 999 ... 2	19	1	OVERLOAD-PROTECTION RELAY VALVE		973 011 201 0
5	1	AIR RESERVOIR		950 0	18	1	RELAY VALVE		973 011 0.. 0
4	1	RELAY EMERGENCY VALVE		971 002 ... 0	17	1	ADAPTER VALVE		975 00. 0.. 0
3	1	DOUBLE RELEASE VALVE		963 001 051 0	16	2	DUMMY COUPLING WITH FIXTURE	*	452 402 000 0
2	1	COUPLING HEAD W.INT.LINE FILTER		952 201 003 0	15	2	KIT	*	423 903 532 2
1	1	COUPLING HEAD W.INT.LINE FILTER		952 201 004 0	14	2	TRISTOP BRAKE ACTUATOR		925 0
Pos.	Pcs.	Denomination		Product Identification No.	Pos.	Pcs.	Denomination		Product Identification No.

Copyright WABCO®		WABCO		TWO LINE-AIR BRAKING SYSTEM	
Date	Signature				
Drawn		FOR 3-AXLES-TRAILER		2xLOAD-SENS.VALVE, OPTION MECH./AIR	
2015-04-13	BURMESTER				
Checked		841 601 138 0		002 EN 1/1	
2015-04-13	CHRONIS				
Expert		ECN-No.		Revision	
BURMESTER					
Mass	Scale	Material No.		Date of first issue:2015-04-13	
KG		841 601 138 0		Doc.Code Language Sheet	
Size	CAD System			002 EN 1/1	
A 3	CREO	Techn. Resp.		Replacement for	
		4990			