

Non e permesso consegnare a terzi o riprodurre questo documento, ne utilizzarne il contenuto o renderlo comunque noto a terzi senza autorizzazione esplicita. Ogni infrazione costituirà un evidente abuso e comporterà il risarcimento dei danni subiti. E' fatta riserva di tutti i diritti derivanti da brevetti o modelli.

Copying of this document and giving it to others and the use or communication of the contents thereof, are forbidden without express authority. Contravention of this restriction will constitute an evident abuse and result in a liability to the payment of damages. All rights are reserved in the event of the grant of patent or registration of a utility model or design. This document is the subject of copyright.

Toute communication ou reproduction de ce document, toute exploitation ou communication de son contenu sont interdites, sauf autorisation expresse. Tout manquement a cette règle constitue un abus évident et expose son auteur au versement de dommages et intérêts. Tous droits de propriété industrielle réservés, notamment en matière de brevets et de modèles.

Weitergabe sowie Vervielfältigung dieser Unterlage, Verwertung und Mitteilung ihres Inhalts nicht gestattet, soweit nicht ausdrücklich zugestanden. Zuwiderhandlungen stellen einen offensichtlichen Missbrauch dar und verpflichten zu Schadenersatz. Alle Rechte rüden Fall der Patentierung oder Gebrauchsmuster-Eintragung vorbehalten.

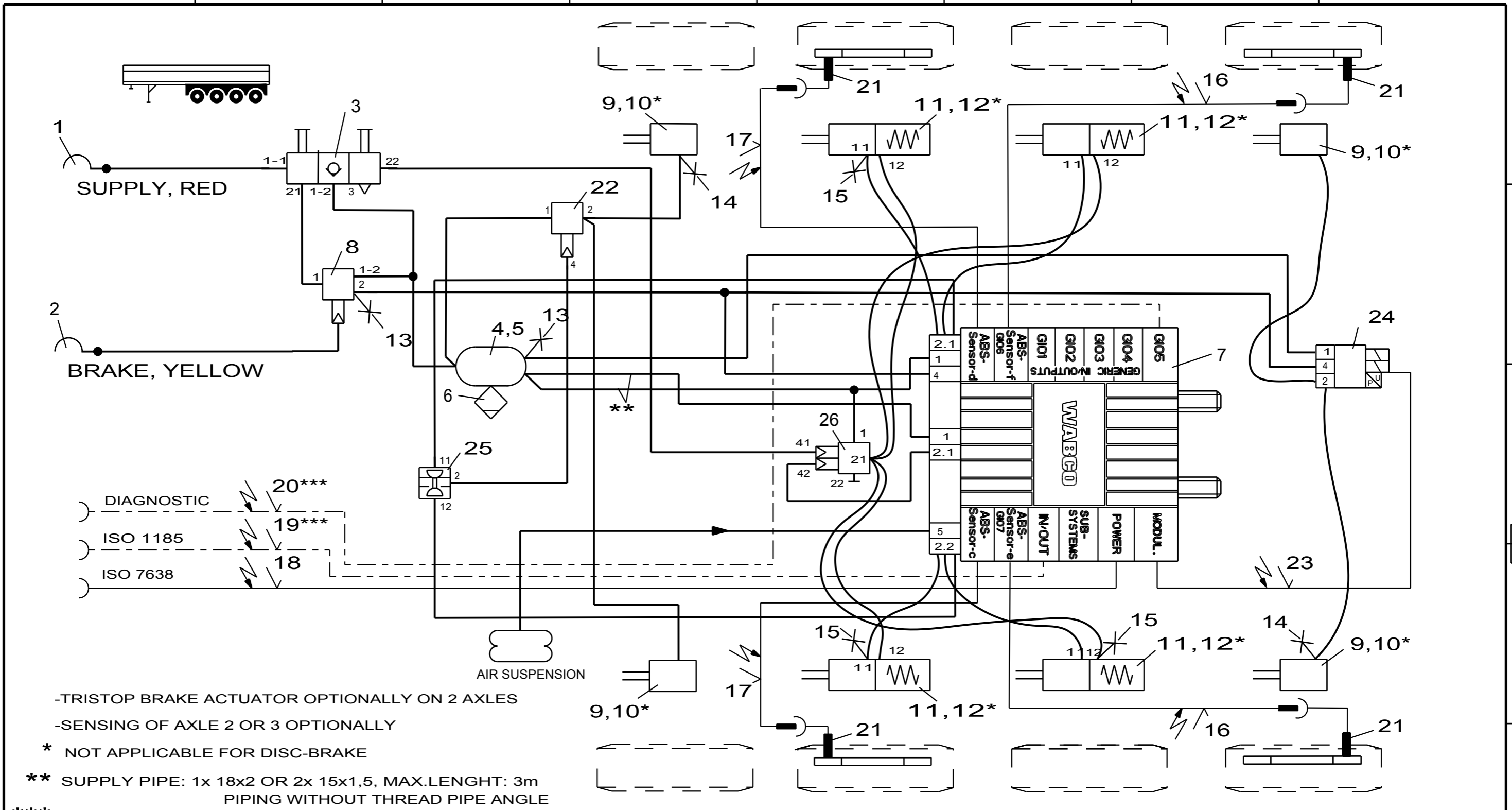

-TRISTOP BRAKE ACTUATOR OPTIONALLY ON 2 AXLES

-SENSING OF AXLE 2 OR 3 OPTIONALLY

* NOT APPLICABLE FOR DISC-BRAKE

** SUPPLY PIPE: 1x 18x2 OR 2x 15x1,5, MAX.LENGTH: 3m
PIPING WITHOUT THREAD PIPE ANGLE

*** OPTIONALLY

12	4	KIT	*	423 903 532 2	26	1	OVERLOAD PROTECTION VALVE		973 011 201 0
11	4	TRISTOP BRAKE ACTUATOR		925 0	25	1	DOUBLE SHUT-OFF VALVE	SELECT LOW	434 500 003 0
10	4	KIT	*	423 000 ... 2	24	1	EBS-RELAY VALVE		480 207 0.. 0
9	4	BRAKE CHAMBER		423 10. ... 0	23	1	CABLE TO EBS-RV		449 429 ... 0
8	1	TRAILER BRAKE VALVE		971 002 301 0	22	1	RELAY VALVE	***	973 011 000 0
7	1	TRAILER-MODULATOR		480 102 06. 0	21	4	ABS-SENSOR		441 032 8.. 0
6	1	DRAIN VALVE		934 300 001 0	20	1	DIAGNOSTIC CABLE	***	449 611 ... 0
5	2	HOSE CLAMP		451 999 ... 0	19	1	24N-CABLE	***	449 349 ... 0
4	1	AIR RESERVOIR		950 0	18	1	SUPPLY (POWER) CABLE		449 173 ... 0
3	1	DOUBLE RELEASE VALVE		963 001 05. 0	17	2	EXTENSION CABLE FOR SENSOR		449 723 ... 0
2	1	COUPLING HEAD W.INT. LINE FILTER		952 201 ... 0	16	2	EXTENSION CABLE FOR SENSOR		449 723 ... 0
1	1	COUPLING HEAD W.INT. LINE FILTER		952 201 ... 0	15	3	TEST CONNECTION		463 703 036 0
Pos.	Pcs.	Denomination		Product Identification No.	Pos.	Pcs.	Denomination		Product Identification No.

Copyright WABCO®		WABCO	
Date	Signature		
2008-10-06	BURMESTER	TRAILER - EBS E	
Checked		FOR 4-AXLES-SEMITRAILER 4S/3M AXLE 1 SELECT LOW	
2008-10-06	CHRONIS		
Expert			
BURMESTER			
Mass	Scale	Material No.	
-	-	841 701 051 0	
KG	-	Date of first issue: 2008-10-06	
Size	CAD System	Doc.Code	Language
A 3	Pro/E	002	EN
		Sheet	1/1
ECN-No.	Revision	Techn. Resp.	Replacement for
124083	B	4990	

100mm