

Non e permesso consegnare a terzi o riprodurre questo documento, ne utilizzare il contenuto o renderlo comunque noto a terzi senza autorizzazione esplicita. Ogni infrazione costituirà un evidente abuso e comporterà il risarcimento dei danni subiti. E' fatta riserva di tutti i diritti derivanti da brevetti o modelli.

Copying of this document and giving it to others and the use or communication of the contents thereof, are forbidden without express authority. Contravention of this restriction will constitute an evident abuse and result in a liability to the payment of damages. All rights are reserved in the event of the grant of patent or registration of a utility model or design. This document is the subject of copyright.

Toute communication ou reproduction de ce document, toute exploitation ou communication de son contenu sont interdites, sauf autorisation expresse. Tout manquement a cette règle constitue un abus évident et expose son auteur au versement de dommages et intérêts. Tous droits de propriété industrielle réservés, notamment en matière de brevets et de modèles.

Weitergabe sowie Vervielfältigung dieser Unterlage, Verwertung und Mitteilung ihres Inhalts nicht gestattet, soweit nicht ausdrücklich zugestanden. Zuwiderhandlungen stellen einen offensichtlichen Missbrauch dar und verpflichten zu Schadenersatz. Alle Rechte rüden Fall der Patentierung oder Gebrauchsmuster-Eintragung vorbehalten.

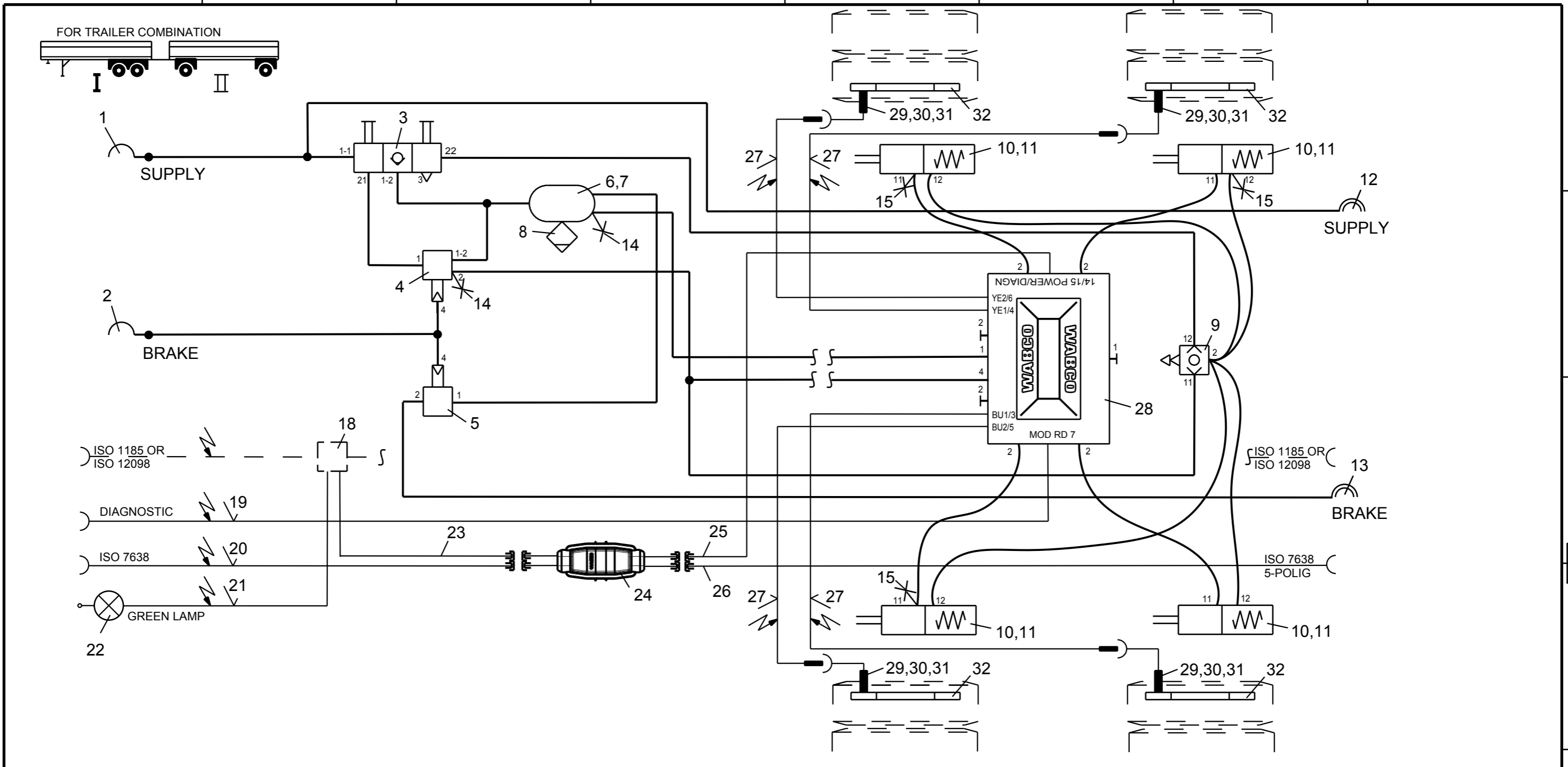

17				35			
16				34			
15	3	TEST CONNECTION	463 703 036 0	32	4	TOOTHED WHEEL	895 905 568 4
14	2	TEST CONNECTION	463 703 115 0	31	4	GREASE	830 503 062 4
13	1	COUPLING HEAD AUTOM.BRAKE	952 200 222 0	30	4	SENSOR-BUSH	899 759 815 4
12	1	COUPLING HEAD AUTOM.SUPPLY	952 200 221 0	29	4	ABS-SENSOR	441 032 808 0
11	4	KIT	423 903 532 2	28	1	VCS2-TRAILER-MODULATOR	400 652 149 0
10	4	TRISTOP BRAKE ACTUATOR	925 3... 0	27	4	EXTENSION CABLE FOR SENSOR	1.8M 449 712 018 0
9	1	2-WAY-QUICK-RELEASE VALVE	973 500 051 0	26	1	CABLE WITH ABS-SOCKET	2.0M 449 132 020 0
8	1	DRAIN VALVE	934 300 001 0	25	1	POWER (SUPPLY) CABLE	2.0M 449 360 020 0
7	2	HOSE CLAMP	451 999 ... 2	24	1	MULTI-DISTRIBUTER	894 600 052 0
6	1	AIR RESERVOIR	950 ... 0	23	1	24N-CABLE W. DIN BAJONETT	10M 449 380 000 0
5	1	RELAY VALVE	973 011 000 0	22	1	GREEN LAMP	446 105 523 2
4	1	TRAILER BRAKE VALVE	971 002 ... 0	21	1	CABLE-GREEN LAMP	10M 449 900 000 0
3	1	DOUBLE RELEASE VALVE	963 001 05. 0	20	1	POWER (SUPPLY) CABLE	12M 449 132 120 0
2	1	COUPLING HEAD W.INT.LINE FILTER	952 201 001 0	19	1	DIAGNOSTIC CABLE	OPTIONAL 3M 449 615 030 0
1	1	COUPLING HEAD W.INT.LINE FILTER	952 201 002 0	18	1	DISTRIBUTER BOX	400 606 650 0
Pos.	Pcs.	Denomination	Product Identification No.	Pos.	Pcs.	Denomination	Product Identification No.

Copyright WABCO		WABCO	
Date	Signature	TWO LINE-AIR BRAKING SYSTEM	
2012-03-13	BURMESTER	TRAILER 1	
Checked		SEMI-DRAWBAR 4S/2M	
2012-03-13	MEISE		
Expert			
BURMESTER			
Mass	Scale	Material No.	Date of first issue:2012-03-13
KG		841 701 127 0	Doc.Code
Size	CAD System		Language
A 3	Pro/E	ECN-No.	Revision
		241211	A
		Techn. Resp.	4990
		Replacement for	

Non e permesso consegnare a terzi o riprodurre questo documento, ne utilizzarne il contenuto o renderlo comunque noto a terzi senza autorizzazione esplicita. Ogni infrazione costituirà un evidente abuso e comporterà il risarcimento dei danni subiti. E' fatta riserva di tutti i diritti derivanti da brevetti o modelli.

Copying of this document and giving it to others and the use or communication of the contents thereof, are forbidden without express authority. Contravention of this restriction will constitute an evident abuse and result in a liability to the payment of damages. All rights are reserved in the event of the grant of patent or registration of a utility model or design. This document is the subject of copyright.

Toute communication ou reproduction de ce document, toute exploitation ou communication de son contenu sont interdites, sauf autorisation expresse. Tout manquement a cette règle constitue un abus évident et expose son auteur au versement de dommages et intérêts. Tous droits de propriété industrielle réservés, notamment en matière de brevets et de modèles.

Weitergabe sowie Vervielfältigung dieser Unterlage, Verwertung und Mitteilung ihres Inhalts nicht gestattet, soweit nicht ausdrücklich zugestanden. Zuwiderhandlungen stellen einen offensichtlichen Missbrauch dar und verpflichten zu Schadenersatz. Alle Rechte rüden Fall der Patentierung oder Gebrauchsmuster-Eintragung vorbehalten.

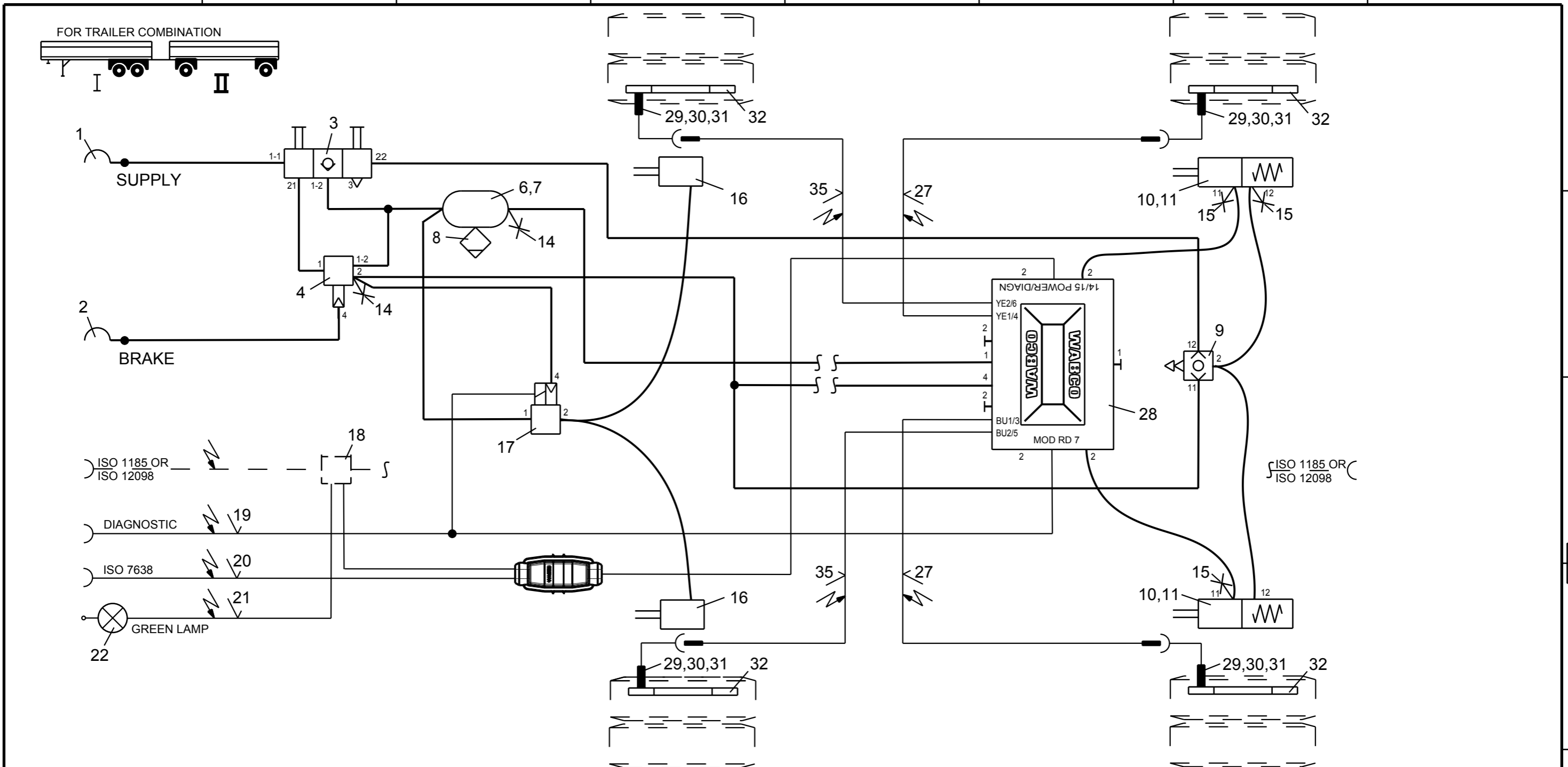

35	2	EXTENSION CABLE FOR SENSOR	7.0M	449 712 070 0
34				
33				
32	4	TOOTHED WHEEL		895 905 568 4
31	4	GREASE		830 503 062 4
30	4	SENSOR-BUSH		899 759 815 4
29	4	ABS-SENSOR		441 032 808 0
28	1	VCS2-TRAILER-MODULATOR		400 652 149 0
27	2	EXTENSION CABLE FOR SENSOR	1.8M	449 712 018 0
26				
25				
24				
23				
22	1	GREEN LAMP		446 105 523 2
21	1	CABLE-GREEN LAMP	10M	449 900 000 0
20	1	POWER (SUPPLY) CABLE	11M	449 224 337 0
19	1	DIAGNOSTIC CABLE		449 616 235 0
18	1	DISTRIBUTOR BOX		400 606 650 0
17	1	ABS-RELAY VALVE		472 195 038 0
16	2	BRAKE CHAMBER		423 0
15	3	TEST CONNECTION		463 703 036 0
14	2	TEST CONNECTION		463 703 115 0
13				
12				
11	2	KIT		423 903 532 2
10	2	TRISTOP BRAKE ACTUATOR		925 3... .. 0
9	1	2-WAY-QUICK-RELEASE VALVE		973 500 051 0
8	1	DRAIN VALVE		934 300 001 0
7	2	HOSE CLAMP		451 999 ... 2
6	1	AIR RESERVOIR		950 0
5				
4	1	TRAILER BRAKE VALVE		971 002 ... 0
3	1	DOUBLE RELEASE VALVE		963 001 05. 0
2	1	COUPLING HEAD W.INT.LINE FILTER		952 201 001 0
1	1	COUPLING HEAD W.INT.LINE FILTER		952 201 002 0

Copyright WABCO®		WABCO	
Date	Signature		
Drawn	2012-03-13	BURMESTER	TWO LINE-AIR BRAKING SYSTEM TRAILER 2 SEMI-DRAWBAR
Checked	2012-03-13	MEISE	
Expert	BURMESTER		
Mass	Scale	Material No.	
KG		841 701 127 0	Date of first issue: 2012-03-13
Size	CAD System	ECN-No.	Doc.Code
A 3	Pro/E	124211	Language
		Revision	Sheet
		A	002 EN 2/2
		Techn. Resp.	Replacement for
		4990	