

Non e permesso consegnare a terzi o riprodurre questo documento, ne utilizzarne il contenuto o renderlo comunque noto a terzi senza autorizzazione esplicita. Ogni infrazione costituirà un evidente abuso e comporterà il risarcimento dei danni subiti. E' fatta riserva di tutti i diritti derivanti da brevetti o modelli.

Copying of this document and giving it to others and the use or communication of the contents thereof, are forbidden without express authority. Contravention of this restriction will constitute an evident abuse and result in a liability to the payment of damages. All rights are reserved in the event of the grant of patent or registration of a utility model or design. This document is the subject of copyright.

Toute communication ou reproduction de ce document, toute exploitation ou communication de son contenu sont interdites, sauf autorisation expresse. Tout manquement a cette règle constitue un abus évident et expose son auteur au versement de dommages et intérêts. Tous droits de propriété industrielle réservés, notamment en matière de brevets et de modèles.

Weitergabe sowie Vervielfältigung dieser Unterlage, Verwertung und Mitteilung ihres Inhalts nicht gestattet, soweit nicht ausdrücklich zugestanden. Zuwiderhandlungen stellen einen offensichtlichen Missbrauch dar und verpflichten zu Schadenersatz. Alle Rechte rüden Fall der Patentierung oder Gebrauchsmuster-Eintragung vorbehalten.

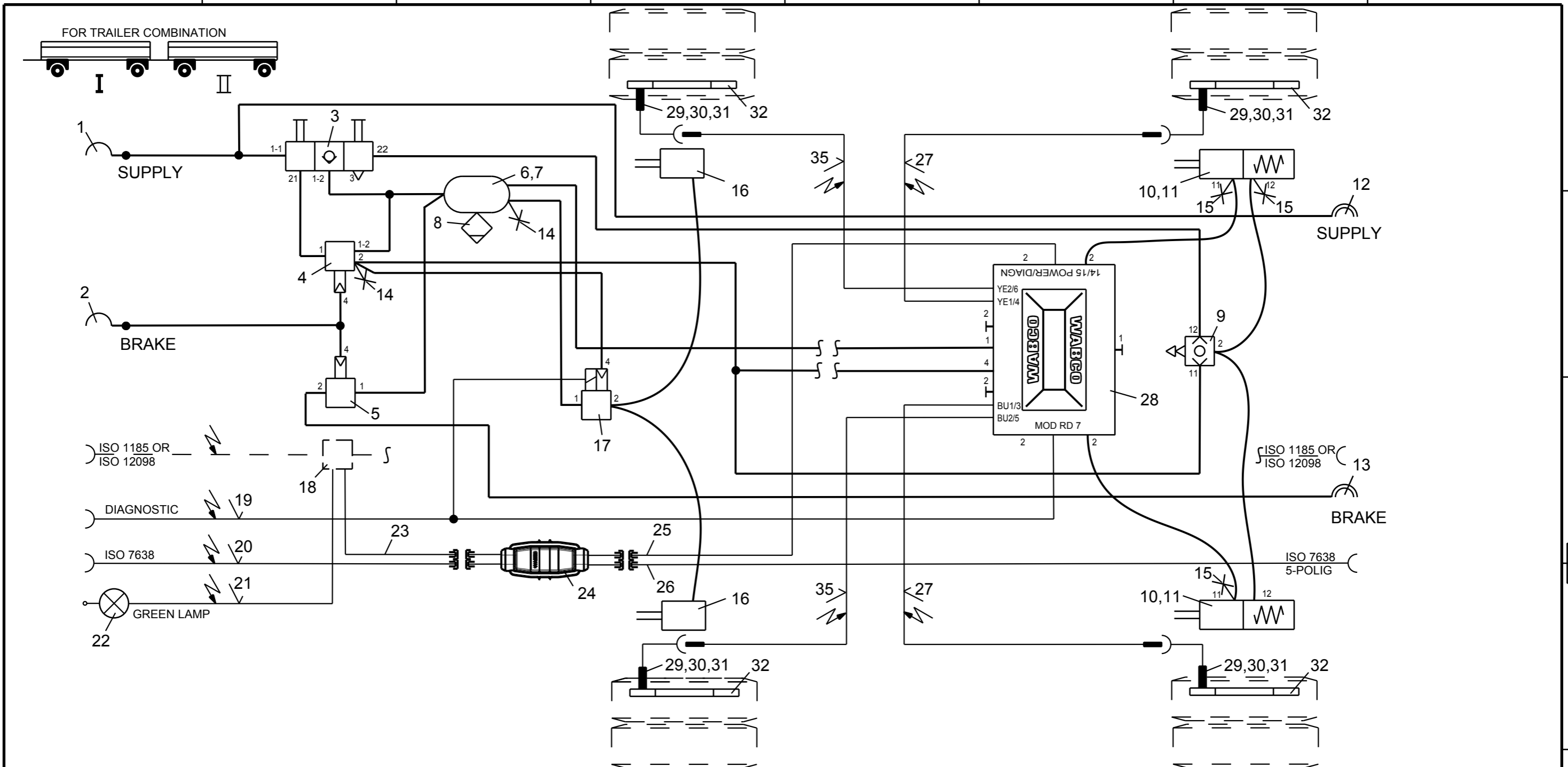

17	1	ABS-RELAY VALVE	472 195 038 0	35	2	EXTENSION CABLE FOR SENSOR	7.0M	449 712 070 0
16	2	BRAKE CHAMBER	423 0	34				
15	3	TEST CONNECTION	463 703 036 0	33				
14	2	TEST CONNECTION	463 703 115 0	32	4	TOOTHED WHEEL		895 905 568 4
13	1	COUPLING HEAD AUTOM.BRAKE	952 200 222 0	31	4	GREASE		830 503 062 4
12	1	COUPLING HEAD AUTOM.SUPPLY	952 200 221 0	30	4	SENSOR-BUSH		899 759 815 4
11	2	KIT	423 903 532 2	29	4	ABS-SENSOR		441 032 808 0
10	2	TRISTOP BRAKE ACTUATOR	925 3... .. 0	28	1	VCS2-TRAILER-MODULATOR		400 652 149 0
9	1	2-WAY-QUICK-RELEASE VALVE	973 500 051 0	27	2	EXTENSION CABLE FOR SENSOR	1.8M	449 712 018 0
8	1	DRAIN VALVE	934 300 001 0	26	1	CABLE WITH ABS-SOCKET	2.0M	449 132 020 0
7	2	HOSE CLAMP	451 999 ... 2	25	1	POWER (SUPPLY) CABLE	2.0M	449 360 020 0
6	1	AIR RESERVOIR	950 0	24	1	MULTI-DISTRIBUTER		894 600 052 0
5	1	RELAY VALVE	973 011 000 0	23	1	24N-CABLE W. DIN BAJONETT	10M	449 380 000 0
4	1	TRAILER BRAKE VALVE	971 002 ... 0	22	1	GREEN LAMP		446 105 523 2
3	1	DOUBLE RELEASE VALVE	963 001 05. 0	21	1	CABLE-GREEN LAMP	10M	449 900 000 0
2	1	COUPLING HEAD W.INT.LINE FILTER	952 201 001 0	20	1	POWER (SUPPLY) CABLE	10M	449 242 100 0
1	1	COUPLING HEAD W.INT.LINE FILTER	952 201 002 0	19	1	DIAGNOSTIC CABLE	8M/5M	449 616 235 0
Pos.	Pcs.	Denomination	Product Identification No.	Pos.	Pcs.	Denomination	Product Identification No.	

Copyright WABCO		WABCO	
Date	Signature	TWO LINE-AIR BRAKING SYSTEM	
2012-03-13	BURMESTER	TRAILER 1	
Checked		DRAWBAR-DRAWBAR	
2012-03-13	MEISE		
Expert			
BURMESTER			
Mass	Scale	Material No.	Date of first issue:2012-03-13
KG		841 701 128 0	Doc.Code
Size	CAD System		Language
A 3	Pro/E	ECN-No.	Sheet
		124211	002
		Revision	EN
		Techn. Resp.	1/2
		4990	Replacement for

Non e permesso consegnare a terzi o riprodurre questo documento, ne utilizzare il contenuto o renderlo comunque noto a terzi senza autorizzazione esplicita. Ogni infrazione costituirà un evidente abuso e comporterà il risarcimento dei danni subiti. E' fatta riserva di tutti i diritti derivanti da brevetti o modelli.

Copying of this document and giving it to others and the use or communication of the contents thereof, are forbidden without express authority. Contravention of this restriction will constitute an evident abuse and result in a liability to the payment of damages. All rights are reserved in the event of the grant of patent or registration of a utility model or design. This document is the subject of copyright.

Toute communication ou reproduction de ce document, toute exploitation ou communication de son contenu sont interdites, sauf autorisation expresse. Tout manquement a cette règle constitue un abus évident et expose son auteur au versement de dommages et intérêts. Tous droits de propriété industrielle réservés, notamment en matière de brevets et de modèles.

Weitergabe sowie Vervielfältigung dieser Unterlage, Verwertung und Mitteilung ihres Inhalts nicht gestattet, soweit nicht ausdrücklich zugestanden. Zuwiderhandlungen stellen einen offensichtlichen Missbrauch dar und verpflichten zu Schadenersatz. Alle Rechte rüden Fall der Patentierung oder Gebrauchsmuster-Eintragung vorbehalten.

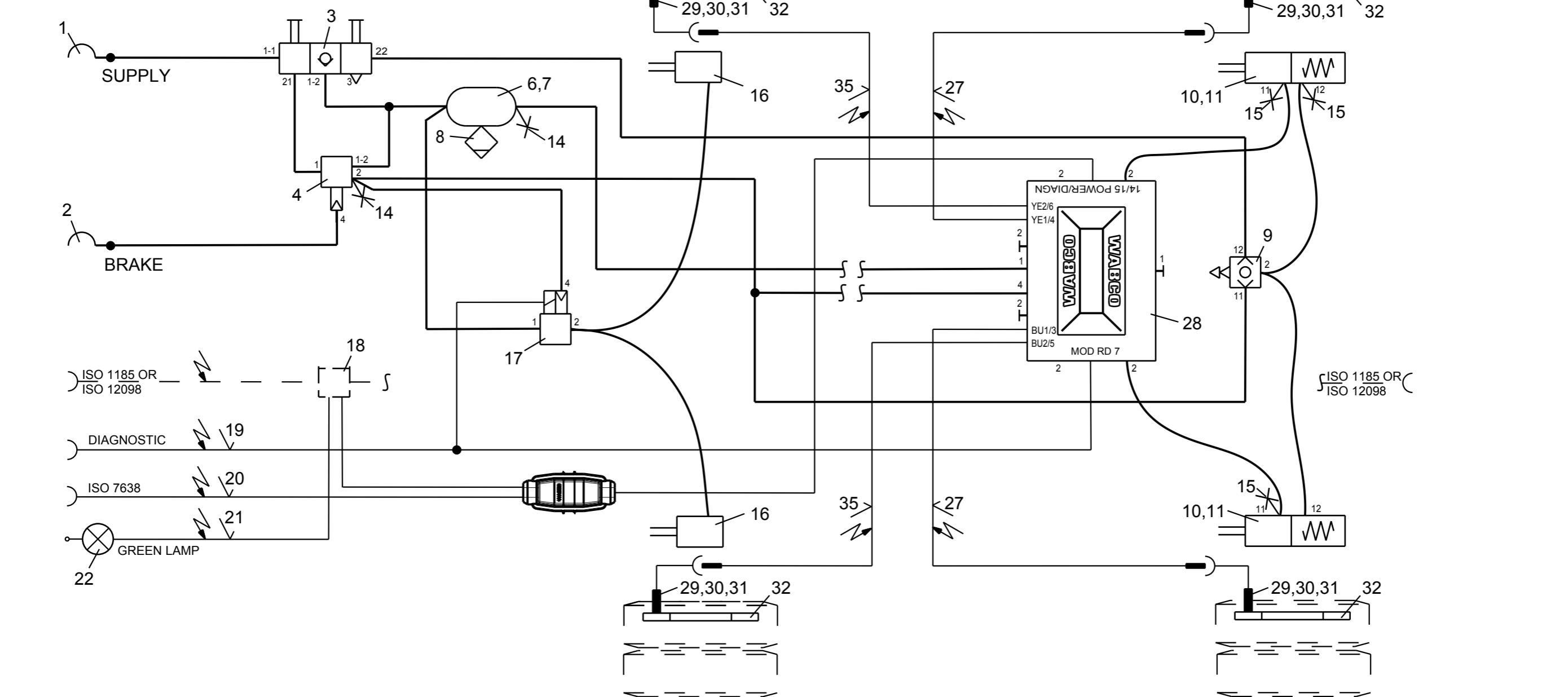

17	1	ABS-RELAY VALVE	472 195 038 0	35	2	EXTENSION CABLE FOR SENSOR	7.0M	449 712 070 0
16	2	BRAKE CHAMBER	423 0	34				
15	3	TEST CONNECTION	463 703 036 0	33				
14	2	TEST CONNECTION	463 703 115 0	32	4	TOOTHED WHEEL		895 905 568 4
13				31	4	GREASE		830 503 062 4
12				30	4	SENSOR-BUSH		899 759 815 4
11	2	KIT	423 903 532 2	29	4	ABS-SENSOR		441 032 808 0
10	2	TRISTOP BRAKE ACTUATOR	925 3... .. 0	28	1	VCS2-TRAILER-MODULATOR		400 652 149 0
9	1	2-WAY-QUICK-RELEASE VALVE	973 500 051 0	27	2	EXTENSION CABLE FOR SENSOR	1.8M	449 712 018 0
8	1	DRAIN VALVE	934 300 001 0	26				
7	2	HOSE CLAMP	451 999 ... 2	25				
6	1	AIR RESERVOIR	950 0	24				
5				23				
4	1	TRAILER BRAKE VALVE	971 002 ... 0	22	1	GREEN LAMP		446 105 523 2
3	1	DOUBLE RELEASE VALVE	963 001 05. 0	21	1	CABLE-GREEN LAMP	10M	449 900 000 0
2	1	COUPLING HEAD W.INT.LINE FILTER	952 201 001 0	20	1	POWER (SUPPLY) CABLE	11M	449 224 337 0
1	1	COUPLING HEAD W.INT.LINE FILTER	952 201 002 0	19	1	DIAGNOSTIC CABLE		449 616 235 0
				18	1	DISTRIBUTOR BOX		400 606 650 0
Pos.	Pcs.	Denomination	Product Identification No.	Pos.	Pcs.	Denomination		Product Identification No.

Copyright WABCO®		WABCO			
Date	Signature				
Drawn	2012-03-13	BURMESTER	TWO LINE-AIR BRAKING SYSTEM TRAILER 2 DRAWBAR-DRAWBAR		
Checked	2012-03-13	MEISE			
Expert	BURMESTER				
Mass	Scale	Material No.		Date of first issue:2012-03-13	
KG		841 701 128 0	Doc.Code	Language	Sheet
Size	CAD System		002	EN	2/2
A 3	Pro/E	ECN-No.	Revision	Techn. Resp.	Replacement for
		124211	A	4990	