

Non e permesso consegnare a terzi o riprodurre questo documento, ne utilizzarne il contenuto o renderlo comunque noto a terzi senza autorizzazione esplicita. Ogni infrazione costituirà un evidente abuso e comporterà il risarcimento dei danni subiti. E' fatta riserva di tutti i diritti derivanti da brevetti o modelli.

Copying of this document and giving it to others and the use or communication of the contents thereof, are forbidden without express authority. Contravention of this restriction will constitute an evident abuse and result in a liability to the payment of damages. All rights are reserved in the event of the grant of patent or registration of a utility model or design. This document is the subject of copyright.

Toute communication ou reproduction de ce document, toute exploitation ou communication de son contenu sont interdites, sauf autorisation expresse. Tout manquement a cette règle constitue un abus évident et expose son auteur au versement de dommages et intérêts. Tous droits de propriété industrielle réservés, notamment en matière de brevets et de modèles.

Weitergabe sowie Vervielfältigung dieser Unterlage, Verwertung und Mitteilung ihres Inhalts nicht gestattet, soweit nicht ausdrücklich zugestanden. Zuwiderhandlungen stellen einen offensichtlichen Missbrauch dar und verpflichten zu Schadenersatz. Alle Rechte rüden Fall der Patentierung oder Gebrauchsmuster-Eintragung vorbehalten.

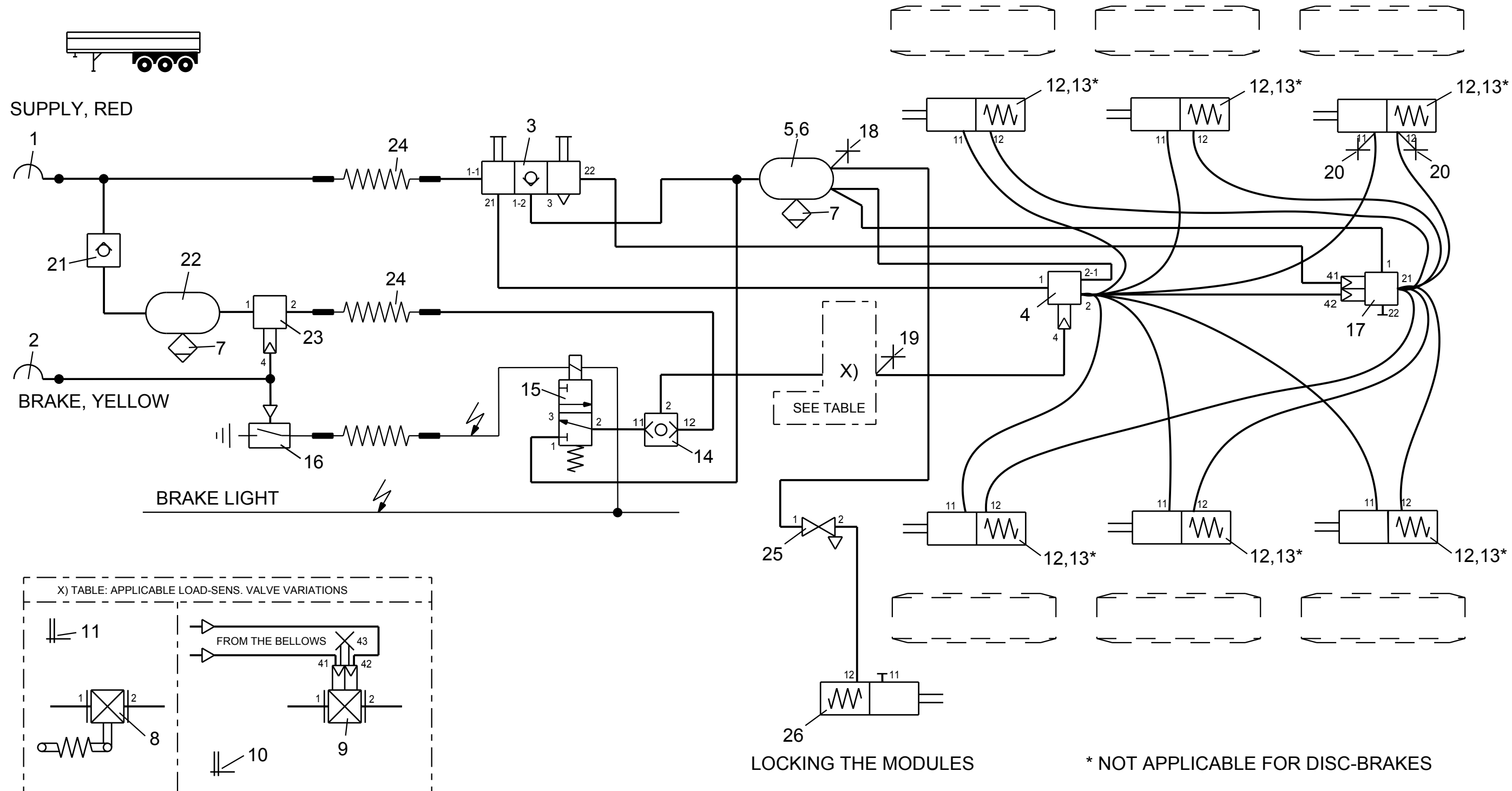

X) TABLE: APPLICABLE LOAD-SENS. VALVE VARIATIONS

13	6	KIT	*	423 903 532 2	26	1	TRISTOP BRAKE ACTUATOR	925 376 100 0
12	6	TRISTOP BRAKE ACTUATOR		925 377 106 0	25	1	SHUT-OFF COCK	952 002 000 0
11	1	TAG "SETTING VALVE OF LSV" MECH.	X)	899 144 630 4	24	2	PNEUMATIC COILED CABLE	452 711 ... 0
10	1	TAG "SETTING VALVE OF LSV" AIR	X)	899 144 631 4	23	1	RELAY VALVE	973 011 000 0
9	1	LOAD-SENS.V. W. INTEGR. TEST VALVE	X)	475 714 5.. 0	22	1	AIR RESERVOIR	950 0
8	1	LOAD-SENS.V. W. INTEGR. FLEX ARM	X)	475 713 50. 0	21	1	CHECK VALVE	434 014 000 0
7	2	DRAIN VALVE		934 300 001 0	20	2	TEST CONNECTION	463 703 036 0
6	2	HOSE CLAMP		451 999 ... 2	19	1	TEST CONNECTION	463 703 120 0
5	1	AIR RESERVOIR		950 0	18	1	TEST CONNECTION	463 703 115 0
4	1	TRAILER BRAKE VALVE		971 002 152 0	17	1	OVERLOAD PROTECTION VALVE	973 011 201 0
3	1	DOUBLE RELEASE VALVE		963 001 05. 0	16	1	PRESSURE SWITCH	441 009 001 0
2	1	COUPLING HEAD W.INT.LINE FILTER		952 201 001 0	15	1	3/2-WAY-VALVE	472 170 604 0
1	1	COUPLING HEAD W.INT.LINE FILTER		952 201 002 0	14	1	2-WAY-VALVE	434 208 029 0
Pos.	Pcs.	Denomination		Product Identification No.	Pos.	Pcs.	Denomination	Product Identification No.

Copyright WABCO®

WABCO

TWO LINE-AIR BRAKING SYSTEM

FOR 3-AXLES-SEMITRAILER

LOAD-SENSING VALVE, OPTIONAL MECH./AIR

Date	Signature				
2012-12-03	BURMESTER				
2012-12-03	CHRONIS				
Expert					
BURMESTER					
Mass	Scale	Material No.	Date of first issue:2012-12-03		
-	-	841 701 159 0	Doc.Code	Language	Sheet
KG	-		002	EN	1/1
Size	CAD System		ECN-No.	Revision	Techn. Resp.
A 3	Pro/E			4990	