

Non e permesso consegnare a terzi o riprodurre questo documento, ne utilizzare il contenuto o renderlo comunque noto a terzi senza autorizzazione esplicita. Ogni infrazione costituirà un evidente abuso e comporterà il risarcimento dei danni subiti. E' fatta riserva di tutti i diritti derivanti da brevetti o modelli.

Copying of this document and giving it to others and the use or communication of the contents thereof, are forbidden without express authority. Contravention of this restriction will constitute an evident abuse and result in a liability to the payment of damages. All rights are reserved in the event of the grant of patent or registration of a utility model or design. This document is the subject of copyright.

Toute communication ou reproduction de ce document, toute exploitation ou communication de son contenu sont interdites, sauf autorisation expresse. Tout manquement a cette regle constitue un abus evident et expose son auteur au versement de dommages et interets. Tous droits de propriete industrielle reserves, notamment en matiere de brevets et de modeles.

Weitergabe sowie Vervielfaeltigung dieser Unterlage, Verwertung und Mitteilung ihres Inhalts nicht gestattet, soweit nicht ausdruecklich zugestanden. Zuwiderhandlungen stellen einen offensichtlichen Missbrauch dar und verpflichten zu Schadenersatz. Alle Rechte fuer den Fall der Patentierung oder Gebrauchsmuster-Eintragung vorbehalten.

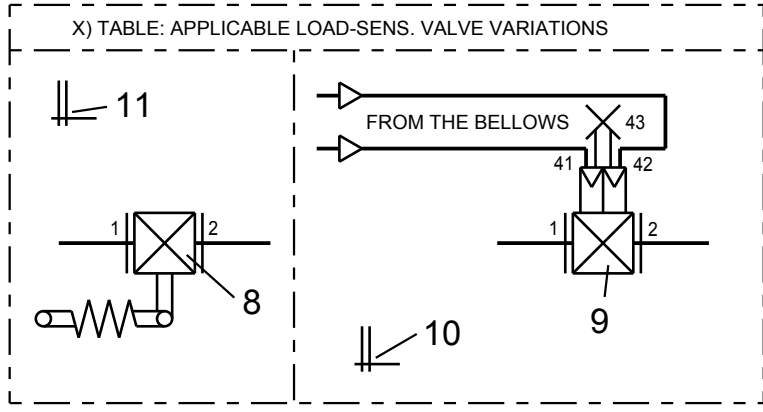
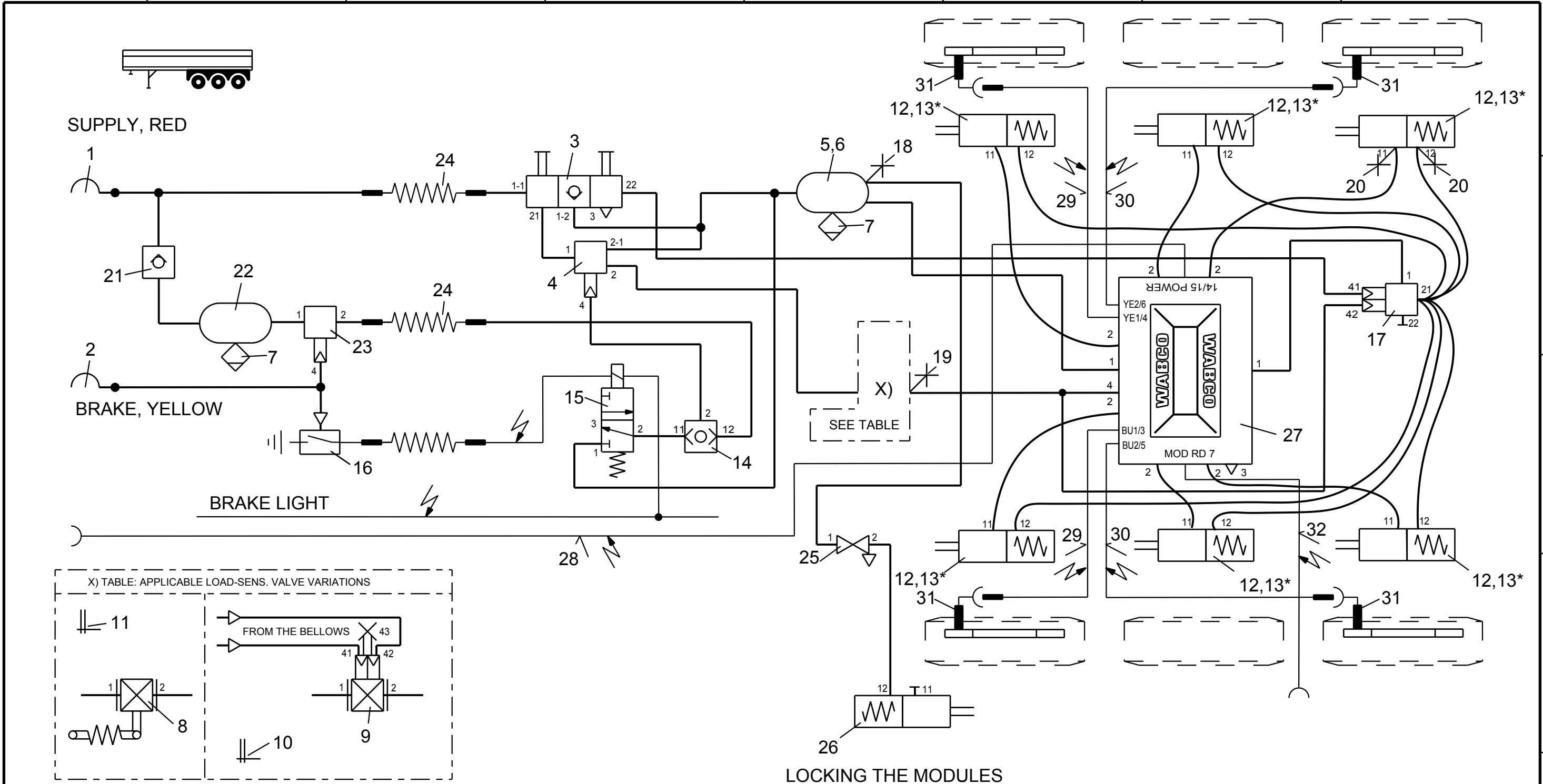

16	1	PRESSURE SWITCH	441 009 001 0	32	1	ABS DIAGNOSTIC CABLE	449 615 0.. 0
15	1	3/2-WAY-VALVE	472 170 604 0	31	4	ABS SENSOR	441 032 ... 0
14	1	2-WAY-VALVE	434 208 029 0	30	2	EXTENSION CABLE FOR SENSOR	449 712 ... 0
13	6	KIT	423 903 532 2	29	2	EXTENSION CABLE FOR SENSOR	449 712 ... 0
12	6	TRISTOP BRAKE ACTUATOR	925 377 106 0	28	1	ABS-SUPPLY CABLE	449 1.. ... 0
11	1	TAG "SETTING VALVE OF LSV" MECH.	X) 899 144 630 4	27	1	VCS2-TRAILER-MODULATOR 24V	400 500 081 0
10	1	TAG "SETTING VALVE OF LSV" AIR	X) 899 144 631 4	26	1	TRISTOP BRAKE ACTUATOR	925 376 100 0
9	1	LOAD-SENS.V. W. INTEGR. TEST VALVE	X) 475 714 5.. 0	25	1	SHUT-OFF COCK	952 002 000 0
8	1	LOAD-SENS.V. W. INTEGR. FLEX ARM	X) 475 713 50. 0	24	2	PNEUMATIC COILED CABLE	452 711 ... 0
7	2	DRAIN VALVE	934 300 001 0	23	1	RELAY VALVE	973 011 000 0
6	2	HOSE CLAMP	451 999 ... 2	22	1	AIR RESERVOIR	950 0
5	1	AIR RESERVOIR	950 0	21	1	CHECK VALVE	434 014 000 0
4	1	TRAILER BRAKE VALVE	971 002 152 0	20	2	TEST CONNECTION	463 703 036 0
3	1	DOUBLE RELEASE VALVE	963 001 05. 0	19	1	TEST CONNECTION	463 703 120 0
2	1	COUPLING HEAD W.INT.LINE FILTER	952 201 001 0	18	1	TEST CONNECTION	463 703 115 0
1	1	COUPLING HEAD W.INT.LINE FILTER	952 201 002 0	17	1	OVERLOAD PROTECTION VALVE	973 011 201 0
Pos.	Pcs.	Denomination	Product Identification No.	Pos.	Pcs.	Denomination	Product Identification No.

* NOT APPLICABLE FOR DISC-BRAKES

Copyright WABCO®		WABCO	TWO LINE-AIR BRAKING SYSTEM		
Date	Signature				
2012-12-10	BURMESTER				
Checked					
2012-12-10	CHRONIS	FOR 3-AXLES-SEMITRAILER ABS VCS2 LOAD-SENSING VALVE, OPTIONAL MECH./AIR			
Expert					
BURMESTER					
Mass	Scale				Material No.
-	-	841 701 280 0	Doc.Code	Language	Sheet
KG	-		002	EN	1/1
Size	CAD System		Replacement for		
A 3	Pro/E	ECN-No.	Revision	Techn. Resp.	4990