

Non e permesso consegnare a terzi o riprodurre questo documento, ne utilizzarne il contenuto o renderlo comunque noto a terzi senza autorizzazione esplicita. Ogni infrazione costituirà un evidente abuso e comporterà il risarcimento dei danni subiti. E' fatta riserva di tutti i diritti derivanti da brevetti o modelli.

Copying of this document and giving it to others and the use or communication of the contents thereof, are forbidden without express authority. Contravention of this restriction will constitute an evident abuse and result in a liability to the payment of damages. All rights are reserved in the event of the grant of patent or registration of a utility model or design. This document is the subject of copyright.

Toute communication ou reproduction de ce document, toute exploitation ou communication de son contenu sont interdites, sauf autorisation expresse. Tout manquement a cette regle constitue un abus evident et expose son auteur au versement de dommages et interets. Tous droits de propriete industrielle reserves, notamment en matiere de brevets et de modeles.

Weitergabe sowie Vervielfältigung dieses Unterlagen, Verwendung und Mitteilung ihres Inhalts nicht gestattet, soweit nicht ausdrücklich zugestanden. Zuwiderhandlungen stellen einen offensichtlichen Missbrauch dar und verpflichten zu Schadenersatz. Alle Rechte rüden Fall der Patentierung oder Gebrauchsmuster-Eintragung vorbehalten.

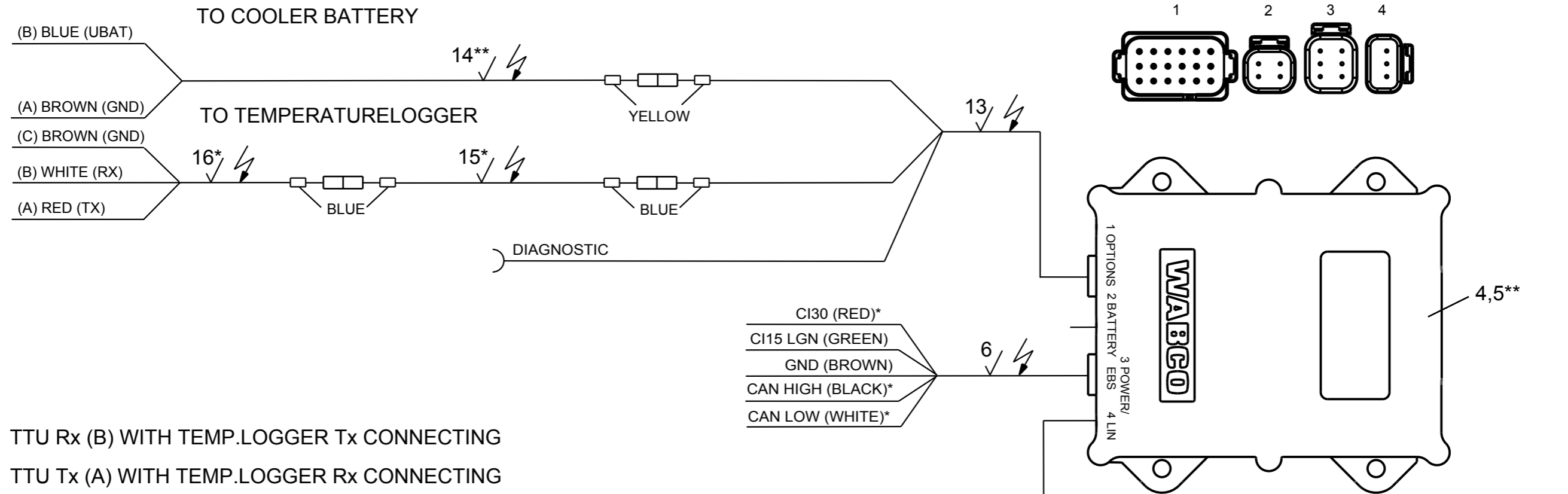

TTU Rx (B) WITH TEMP.LOGGER Tx CONNECTING
 TTU Tx (A) WITH TEMP.LOGGER Rx CONNECTING

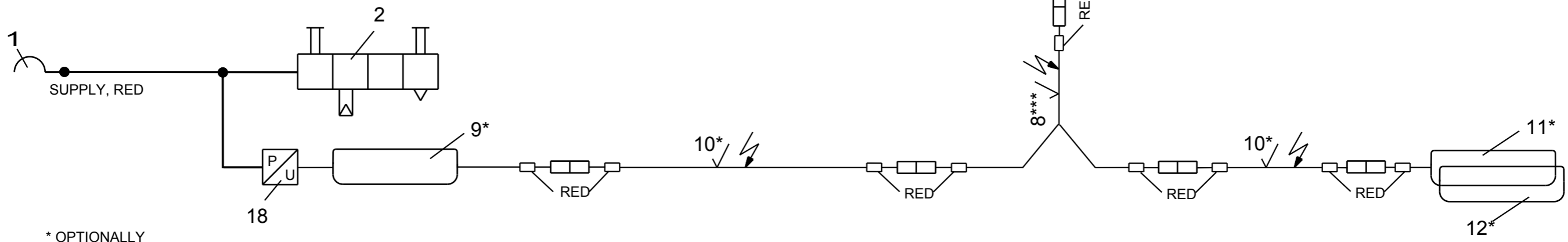

* OPTIONALLY
 ** EITHER LIN AKKU OR CONNECTION AT COOLER BATTERY NECESSARY
 *** ONLY NECESSARY, IF MORE THAN 1 LIN SENSOR IS ATTACHED

Pos.	Pcs.	Denomination	Product Identification No.	Pos.	Pcs.	Denomination	Product Identification No.
12	1	SOLENOID FOR DOOR SENSOR	446 290 261 0				
11	1	DOOR SENSOR	446 290 25. 0				
10	1	EXTENSION CABLE	449 747 ... 0				
9	1	CLUTCH CONVERTER	446 290 231 0				
8	1	Y-CABLE	894 600 024 0				
7	1	CABLE	449 745 ... 0				
6	1	SUPPLY (POWER) CABLE	449 919 ... 0	18	1	PRESSURE SENSOR 5V	441 044 110 0
5	1	BATTERIE TELEMATIC	446 290 150 0	17			
4	1	TRAILER TELEMATIC UNIT PACK	446 290 110 0	16	1	CABLE	449 718 ... 0
3				15	1	EXTENSION CABLE	449 746 ... 0
2	1	PARK-RELEASE-EMERG. VALVE (PREV)	971 002 9.. 0	14	1	CABLE WITH COUPLING PLUG	449 748 ... 0
1	1	COUPLING HEAD W. INT. LINE FILTER	952 201 ... 0	13	1	CABLE WITH SOCKET	894 600 025 0

Copyright WABCO®

WABCO

TRAILER - TELEMATICS

Date	Signature				
2010-08-24	BURMESTER				
Checked					
2010-08-24	STADERMANN				
Expert					
BURMESTER					
Mass	Scale	Material No.	Date of first issue: 2010-08-24		
KG		841 802 203 0	Doc.Code	Language	Sheet
Size	CAD System		002	EN	1/1
A 3	Pro/E	ECN-No.	Revision	Techn. Resp.	Replacement for
		124143	B	4990	