

Non e permesso consegnare a terzi o riprodurre questo documento, ne utilizzarne il contenuto o renderlo comunque noto a terzi senza autorizzazione esplicita. Ogni infrazione costituirà un evidente abuso e comporterà il risarcimento dei danni subiti. E' fatta riserva di tutti i diritti derivanti da brevetti o modelli.

Toute communication ou reproduction de ce document, toute exploitation ou communication de son contenu sont interdites, sauf autorisation expresse. Tout manquement a cette regle constitue un abus evident et expose son auteur au versement de dommages et interets. Tous droits de propriete industrielle reserves, notamment en matiere de brevets et de modeles.

Copying of this document and giving it to others and the use or communication of the contents thereof, are forbidden without express authority. Contravention of this restriction will constitute an evident abuse and result in a liability to the payment of damages. All rights are reserved in the event of the grant of patent or registration of a utility model or design. This document is the subject of copyright.

Weitergabe sowie Vervielfältigung dieses Unterlage, Verwertung und Mitteilung ihres Inhalts nicht gestattet, soweit nicht ausdrücklich zugestanden. Zuwiderhandlungen stellen einen offensichtlichen Missbrauch dar und verpflichten zu Schadenersatz. Alle Rechte rüden Fall der Patentierung oder Gebrauchsmuster-Eintragung vorbehalten.

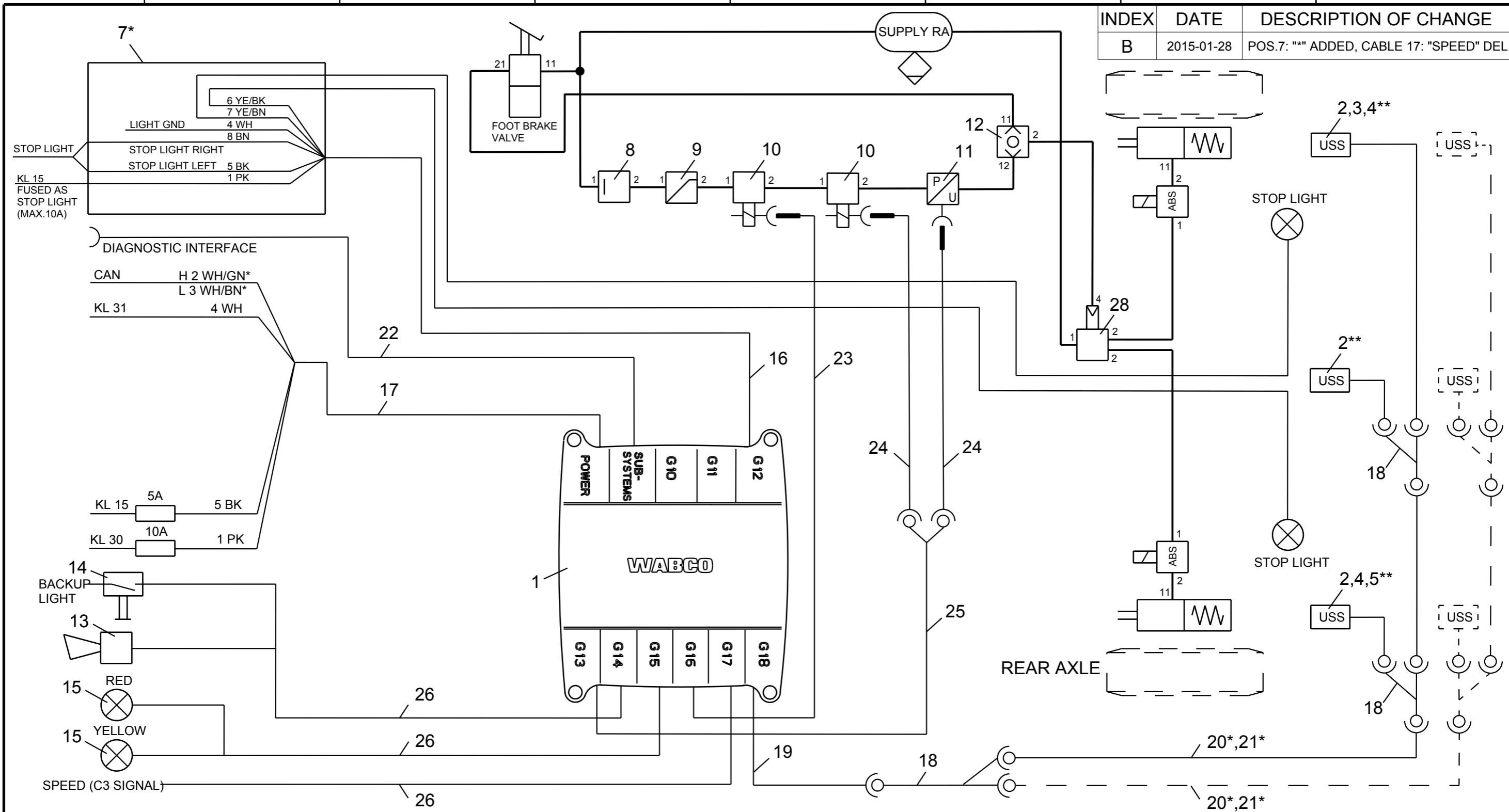

INDEX	DATE	DESCRIPTION OF CHANGE
B	2015-01-28	POS.7: "" ADDED, CABLE 17: "SPEED" DEL.

14	1	RMS OFF-SWITCH	NA	28	1	LOAD SENSING VALVE (LSV)	VEHICLE SPEC.
13	1	BUZZER	894 450 000 0	27			
12	1	DOUBLE CHECK VALVE	434 208 ... 0	26	**	GIO UNIVERSAL CABLE	449 535 000 0
11	1	PRESSURE SENSOR	441 044 101 0	25	1	Y-CABLE-PRESS.SENS./SOLENOID VALVE	449 629 000 0
10	2	SOLENOID VALVE	472 170 606 0	24	2	CABLE PRESS.SENS./SOLENOID VALVE	449 752 000 0
9	1	PRESSURE LIMITING VALVE	475 010 313 0	23	1	CABLE SOLENOID VALVE	449 443 000 0
8	1	CHARGING VALVE	434 100 033 0	22	1	DIAGNOSTIC CABLE	449 605 000 0
7	1	CABLE JUNCTION BOX	* 446 122 633 0	21	**	EXTENSION CABLE	449 747 000 0
6				20	**	EXTENSION CABLE	449 720 000 0
5	**	ULTRASONIC SENSOR 15° DEF LEFT	446 122 404 0	19	1	GIO CABLE LIN SENSOR	449 806 000 0
4	**	ULTRASONIC SENSOR 15° 30CM CABLE	446 122 403 0	18	**	LIN DISTRIBUTOR	894 600 024 0
3	**	ULTRASONIC SENSOR 15° DEF RIGHT	446 122 402 0	17	1	CABLE POWER SUPPLY	449 305 000 0
2	**	ULTRASONIC SENSOR 0°	446 122 401 0	16	1	CABLE UNIVERSAL	449 908 000 0
1	1	ELEX	446 122 070 0	15	2	AUXILIARY INDICATION LIGHTS	NA
Pos.	Pcs.	Denomination	Product Identification No.	Pos.	Pcs.	Denomination	Product Identification No.

* OPTIONALLY
** FOR QUANTITY SEE SPEC. 815 010 211 3 / 815 020 211 3

Copyright WABCO		WABCO
Date	Signature	
2013-11-20	BURMESTER	
2013-11-20	ALKER	
Checked		TAILGUARD FOR TRUCK AND BUS APPLICATION FOR ABS VEHICLE, OPTION BRAKE APPLICATION INDICATION BY AUXILIARY LIGHTS AND BUZZER STOP LIGHT SUPPLY BY KL15
Expert		
BURMESTER		
Mass	Scale	Material No.
-	-	841 802 342 0
Size	CAD System	Doc.Code
A 3	CREO	002
		Language
		EN
		Sheet
		1/1
ECN-No.	Revision	Techn. Resp.
	B	4990
Replacement for		