

Non e permesso consegnare a terzi o riprodurre questo documento, ne utilizzare il contenuto o renderlo comunque noto a terzi senza autorizzazione esplicita. Ogni infrazione costituira un evidente abuso e comportera il risarcimento dei danni subiti. E' fatto riserva di tutti i diritti derivanti da brevetti o modelli.

Man e permisso consegnare a terzi o riprodurre questo documento, ne utilizzare il contenuto o renderlo comunque noto a terzi senza autorizzazione esplicita. Ogni infrazione costituira un evidente abuso e comportera il risarcimento dei danni subiti. E' fatto riserva di tutti i diritti derivanti da brevetti o modelli.

Toute communication ou reproduction de ce document, toute exploitation ou communication de son contenu sont interdites, sauf autorisation expresse. Tout manquement a cette regle constitue un abus evident et expose son auteur au versement de dommages et interets. Tous droits de propriete industrielle reserves, notamment en matiere de brevets et de modesles.

Weitergabe sowie Vervielfaeligung dieser Unterlage, Verwertung und Mitteilung ihres Inhalts nicht gestattet, soweit nicht ausdruecklich zugestanden. Zuwiderhandlungen stellen einen offensichtlichlichen Misbrauch dar und verpflichten zu Schadenersatz. Alle Rechte fuer den Fall der Patenterteilung oder Gebrauchsmuster-Eintragung vorbehalten.

1	2	3	4	5	6	7	8			
A	B	C	D	E	F	G	H	I	J	K
for Tube 16x2,0 new Line <CI>	M22x1,5	9	Hex.28	∅27,7	39	34Nm (40Nm)	(27) Push in length <CI>	2	∅28,3	with O-ring

G : recommended torque without lubrication (max. torque) respect max torque of counter part

Cleanliness requirement:  
Class: K00 according JED-593  
Area: for the whole part (Special agreements possible;  
to be agreed with Product Engineering)

- Material:
- ① CuZn
  - ② PA (inner components)
  - ③ EPDM

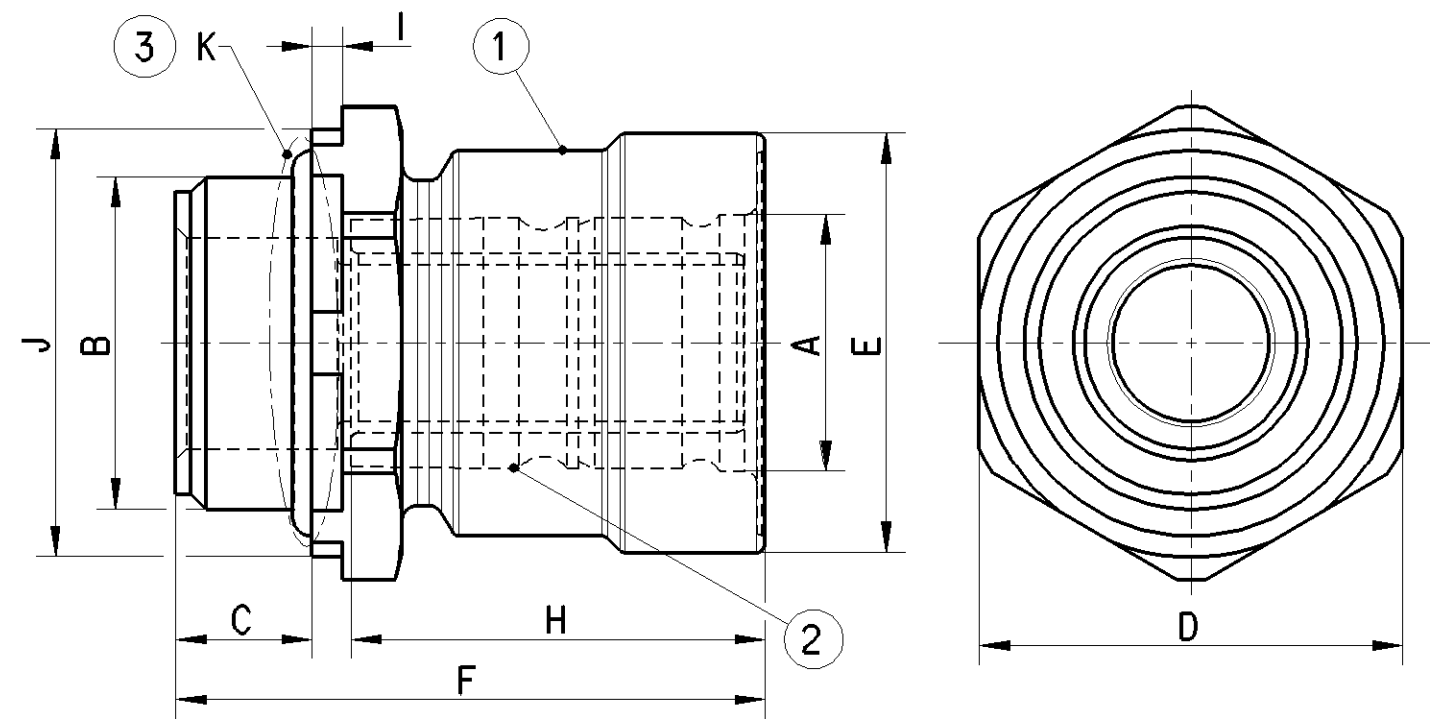

General Specification : JED-762 ; JED-622 ; JED-220  
Engineering related agreements with Supplier have to be mentioned in the "Release of Supplier"

- For use in application in compressed air systems in commercial vehicles :
- with Polyamid or Hyrel tubes acc. ISO7628; DIN74324, DIN73378
  - with compressed air acc. JED-848
  - at working conditions (consider tube spec.) :
    - -40 °C ... 100 °C
    - max. 12,5 bar

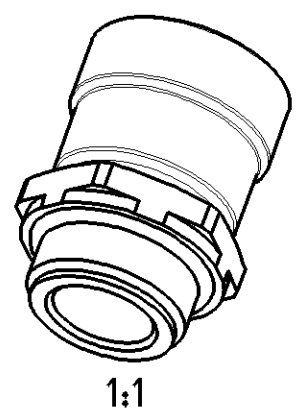

General Specification: JED-334-1, Size ISO 14405 LP				Copyright WABCO®		<b>WABCO</b>				
Further Technical Data:				Date	Signature					
Doc. Code:		Sheet:		To		Fitting				
General Tolerances				2019-11-29		Balogo				
Range of Nominal Dimensions ( ± mm)				Checked		2019-12-11				
				Expert		Szczulkowski				
				Szczulkowski						
Class	1)	≤ 50				> 50	> 180	> 400	> 400	±3°
Fine	X	0.5	1.0	1.5	2.0					
Medium		1.0	2.0	3.0	4.0					
Coarse		2.0	3.5	5.0	6.5					
Tapped Holes acc. -				A 3		CREO				
1) Tolerance Class Applied Crossmarked										
Mass		Scale		Material No.			Date of first issue: 2006-12-14			
0.066 KG		2:1 1:1		893 800 003 2			Doc.Code Language Sheet			
Size		CAD System		ECN-No.		Revision		Techn. Resp.		
A 3		CREO		502571		2 x C		5790		
				Replacement for						

100mm