

Non e permesso consegnare a terzi o riprodurre questo documento, ne utilizzare il contenuto o renderlo comunque noto a terzi senza autorizzazione esplicita. Ogni infrazione costituira un evidente abuso e comportera il risarcimento dei danni subiti. E' fatto riserva di tutti i diritti derivanti da brevetti o modelli.

Copying of this document and giving it to others and the use or communication of the contents thereof, are forbidden without express authority. Controvention of this restriction will constitute an evident abuse and result in a liability to the payment of damages. All rights are reserved in the event of the grant of patent or registration of a utility model or design. This document is the subject of copyright.

Toute communication ou reproduction de ce document, toute exploitation ou communication de son contenu sont interdites, sauf autorisation expresse. Tout manquement a cette regle constitue un abus evident et expose son auteur au versement de dommages et interets. Tous droits de propriete industrielle reserves, notamment en matiere de brevets et de modesles.

Weitergabe sowie Vervielfaeligung dieser Unterlage, Verwertung und Mitteilung ihres Inhalts nicht gestattet, soweit nicht ausdru cklich zugestanden. Zuwiderhandlungen stellen einen offensichtlichlichen Missbrauch dar und verpflichten zu Schadensersatz. Alle Rechte fuer den Fall der Patenterteilung oder Gebrauchsmuster-Eintragung vorbehalten.

1	2	3	4	5	6	7	8
A	B	C	D	E	F	G	H
for Tube 10x1,25 new Line <CI>	M22x1,5	9	Hex.28	Ø20	29	34Nm (40Nm)	(24) Push in length <CI>
C							C

G : recommended torque without lubrication (max. torque) respect max torque of counter part

Cleanliness requirement:
Class: K00 according JED-593

Area: for the whole part (Special agreements possible;
to be agreed with Product Engineering)

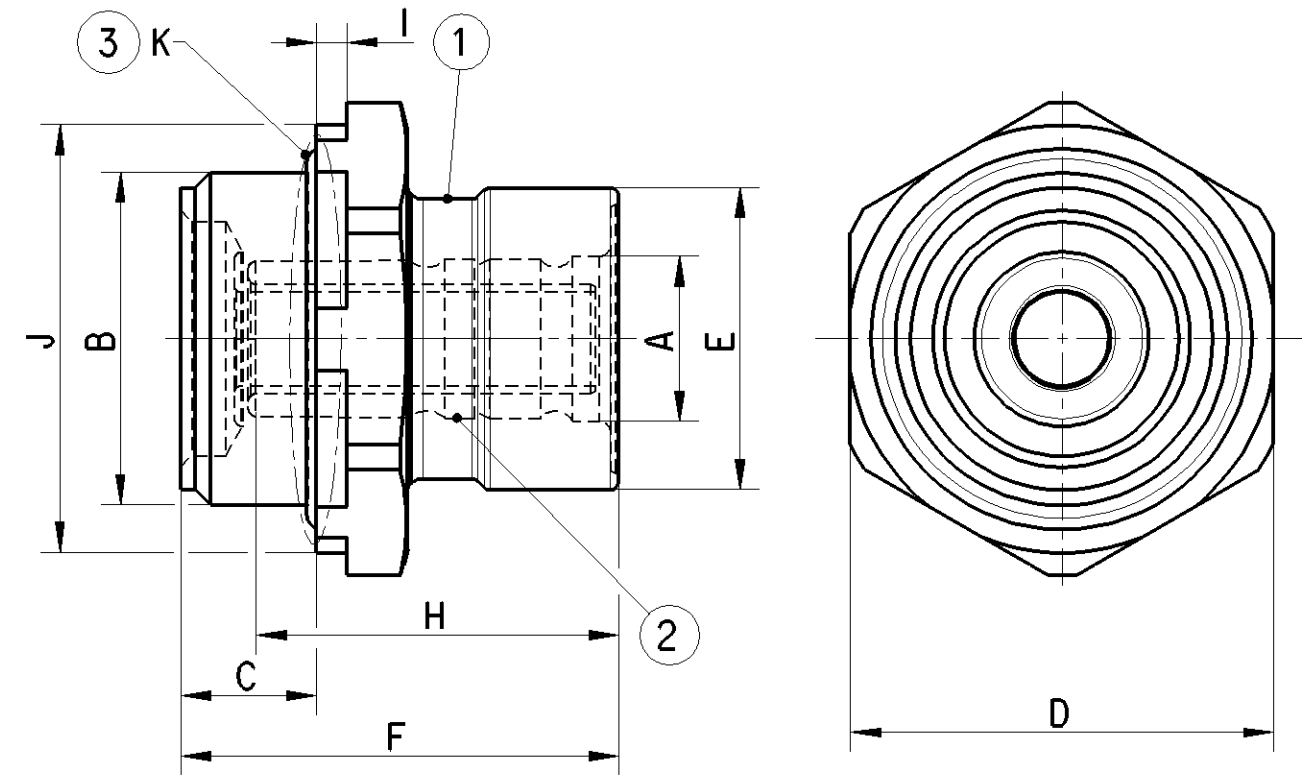

- Material:
- 1 CuZn
 - 2 PA (inner components)
 - 3 EPDM

General Specification : JED-762 ; JED-622 ; JED-220
Engineering related agreements with Supplier have to be mentioned in the "Release of Supplier"

For use in application in compressed air systems in commercial vehicles :

- with Polyamind or Hytel tubes acc. ISO7628; DIN74324, DIN73378
- with compressed air acc. JED-848
- at working conditions (consider tube spec.) :
 - -40 °C ... 100 °C
 - max. 12,5 bar

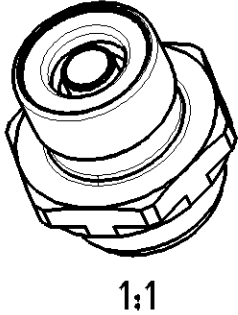

General Specification: JED-334-1, Size ISO 14405 LP		Copyright WABCO®		WABCO	
Further Technical Data:		Date	Signature		
Doc. Code:	Sheet: To	Drawn		Quick Coupling	
General Tolerances JED-261		2019-11-29	Balago		
Range of Nominal Dimensions (± mm)		Checked		Date of first issue: 2013-08-09	
Class 1)	≤ 50 > 50 > 180 > 180 > 400 > 400	2019-12-11 Szczulkowski			
Fine	X 0.5 1.0 1.5 2.0	Expert		Material No.	
Medium	1.0 2.0 3.0 4.0	Szczulkowski		893 800 821 2	
Coarse	2.0 3.5 5.0 6.5	Szc		Date of first issue: 2013-08-09	
Tapped Holes acc. -		Mass	Scale	Doc.Code Language Sheet	
1) Tolerance Class Applied Crossmarked		0.056 KG	2:1 1:1	005 EN 1/1	
		Size	CAD System	Replacement for	
		A 3	CREO	ECN-No.	Revision Techn. Resp.
				502571	2 x C 5790