

Non e permesso consegnare a terzi o riprodurre questo documento, ne utilizzare il contenuto o renderlo comunque noto a terzi senza autorizzazione esplicita. Ogni infrazione costituira un evidente abuso e comportera il risarcimento dei danni subiti. E' fatto riserva di tutti i diritti derivanti da brevetti o modelli.

Copying of this document and giving it to others and the use or communication of the contents thereof, are forbidden without express authority. Controvention of this restriction will constitute an evident abuse and result in a liability to the payment of damages. All rights are reserved in the event of the grant of patent or registration of a utility model or design. This document is the subject of copyright.

Toute communication ou reproduction de ce document, toute exploitation ou communication de son contenu sont interdites, sauf autorisation expresse. Tout manquement a cette regle constitue un abus evident et expose son auteur au versement de dommages et interets. Tous droits de propriete industrielle reserves, notamment en matiere de brevets et de modesles.

Weitergabe sowie Vervielfaeligung dieser Unterlage, Verwertung und Mitteilung ihres Inhalts nicht gestattet, soweit nicht ausdruecklich zugestanden. Zuwiderhandlungen stellen einen offensichtlichen Missbrauch dar und verpflichten zu Schadenersatz. Alle Rechte fuer den Fall der Patenterteilung oder Gebrauchsmuster-Eintragung vorbehalten.

1	2	3	4	5	6	7	8
A	B	C	D	E	F	G	
Ø12	Ø12	MAX.16	HEX.24	HEX.24	~75	ISO8434-1-BHSC	

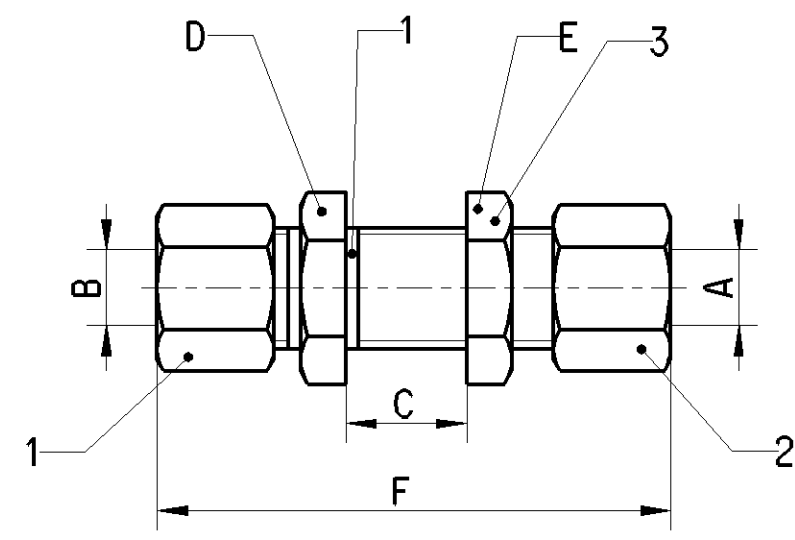

- ① MATERIAL : Steel
SURFACE PROTECTION : gal Zn CrVI free
- ② MATERIAL : Steel
SURFACE PROTECTION : gal Zn CrVI free
- ③ MATERIAL : Steel
SURFACE PROTECTION : gal Zn CrVI free

CLEANLINESS REQUIREMENT:

CLASS: K00 ACCORDING JED-593

AREA: FOR THE WHOLE PART (SPECIAL AGREEMENTS POSSIBLE;
TO BE AGREED WITH PRODUCT ENGINEERING)

GENERAL SPECIFICATION : JED-762 ; JED-622 ; JED-220

ENGINEERING RELATED AGREEMENTS WITH SUPPLIER HAVE TO BE MENTIONED
IN THE "RELEASE OF SUPPLIER"

First production samples, samples from new or modified moulds or changes of every kind must be approved Engineering Department

Teile der ersten Produktion, Teile aus neuen oder geaenderten Formwerkzeugen oder Aenderungen jeglicher Art beduerfen der Genehmigung durch die Entwicklungsabteilung

Les premieres pieces de production, les pieces provenant de nouveaux moules ou de moules modifies, ou toutes autres modification, doivent etre approuvees par le departement des etudes

Campioni di inizio produzione, campioni ottenuti con stampi nuovi o modificati o con qualsiasi genere di modica devono essere approvati dall'ufficio tecnico.

General Specification: JED-334-1 , Size ISO 14405 LP		Copyright WABCO®		WABCO	
Further Technical Data:		Date	Signature		
Doc. Code:	Sheet: To	Drawn		Fitting Verschraubung - BHSC Raccord Raccordo	
General Tolerances JED-261		2019-09-13	Bolago		
Range of Nominal Dimensions (± mm)		Checked		Date of first issue: 2020-05-14	
Class 1)	≤ 50 > 50 > 180 > 400 > 400	2020-05-14			
Fine	0.5 1.0 1.5 2.0	Expert		005	EN
Medium	1.0 2.0 3.0 4.0	Szczulkowski		1/1	
Coarse	2.0 3.5 5.0 6.5	Szczulkowski		Replacement for	
Tapped Holes acc. JED-152		Mass	Scale		
1) Tolerance Class Applied Crossmarked		0.154 KG	/	893 820 574 0	
		Size	CAD System	ECN-No.	Revision
		A 3	CREO	-	-
				Techn. Resp.	5790

1	2	3	4	5	6	7	8
							100mm