

-CI> CUSTOMER INTERFACE		0
18 H11		+0.110 0
16 f11		-0.016 -0.126

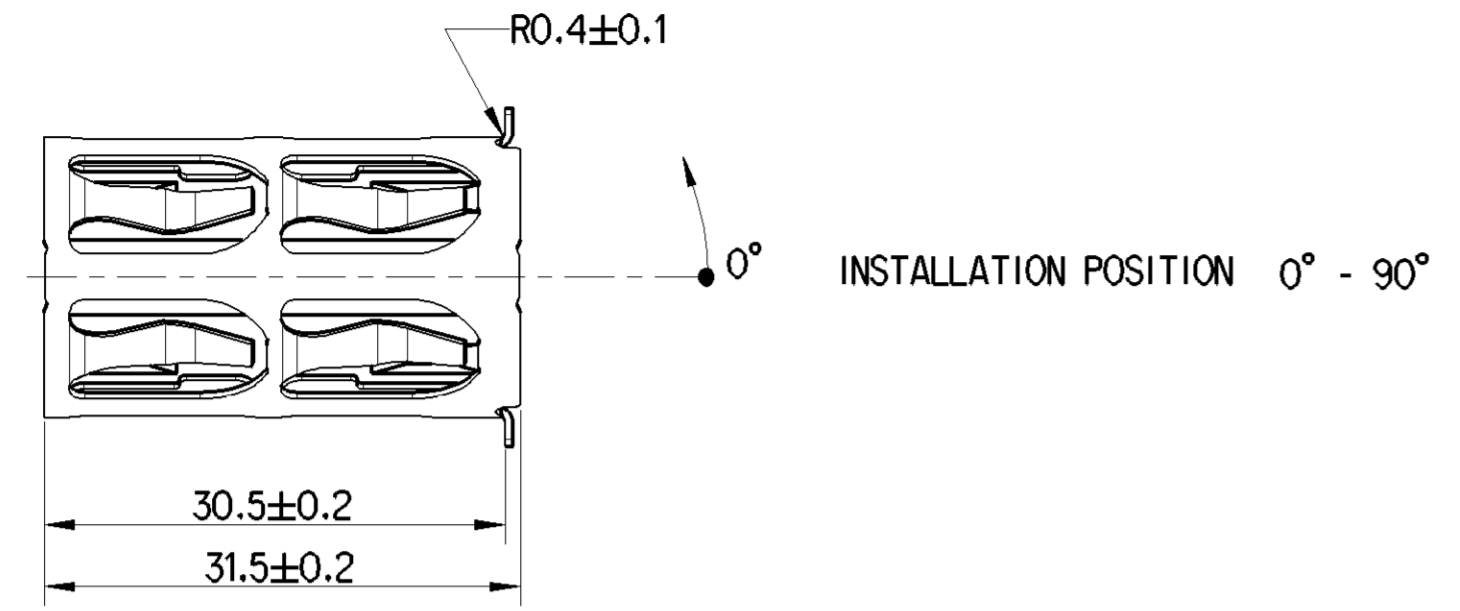

TECHNICAL SPECIFICATION :

- CLAMPING FORCE : 120N ~~30N~~ (MEASURED WITH BORE $\varnothing 18.110$ AND MANDREL $\varnothing 15.874$)
- MATERIAL : JED-792-3
- THERMAL RANGE OF APPLICATION : $-40^\circ\text{C} \dots +180^\circ\text{C}$
- GREASE IN BORE MANDATORY : SEE PRODUCT SPECIFICATION 441 032 100 0
- RESISTANT TO : AIR, WATER, MINERAL OIL, PETROL, DIESEL OIL, SALT SPRAY
- FOR FURTHER TECHNICAL DATA } SEE PRODUCT SPECIFICATION 894 501 001 4

CORROSION TESTS HAVE BEEN PERFORMED IN COMBINATION WITH RETAINER MADE OUT OF S235JR2 (1.0038), SI37 (1.0037) AND AlCuMg1 (3.1325) MATERIAL, ANOMALOUS MATERIAL COMBINATIONS HAVE TO BE CHECKED IN RESPONSIBILITY OF THE CUSTOMER

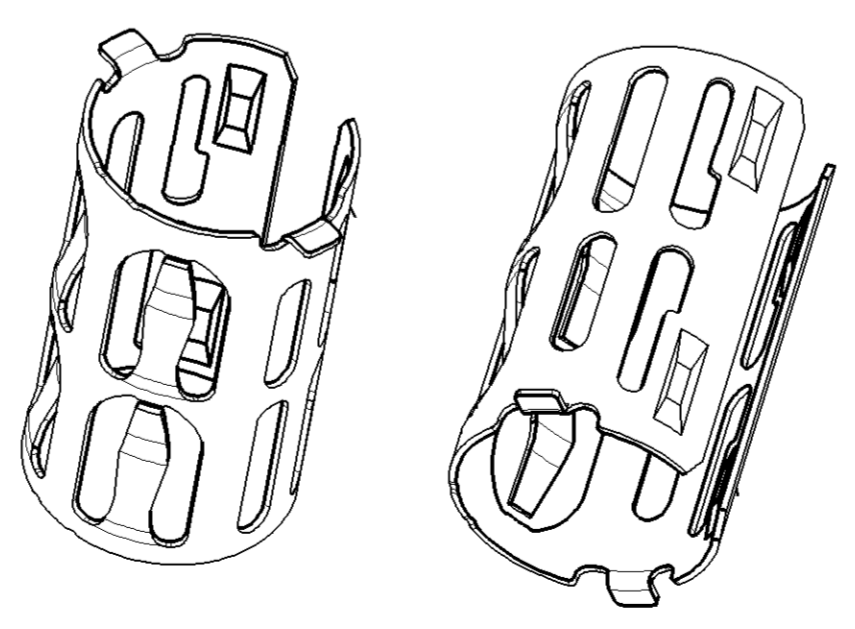
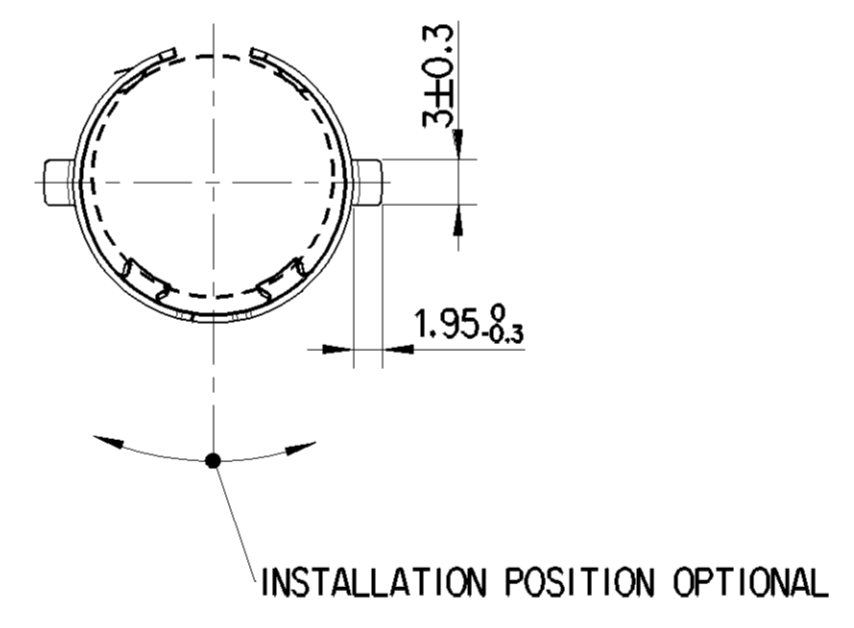
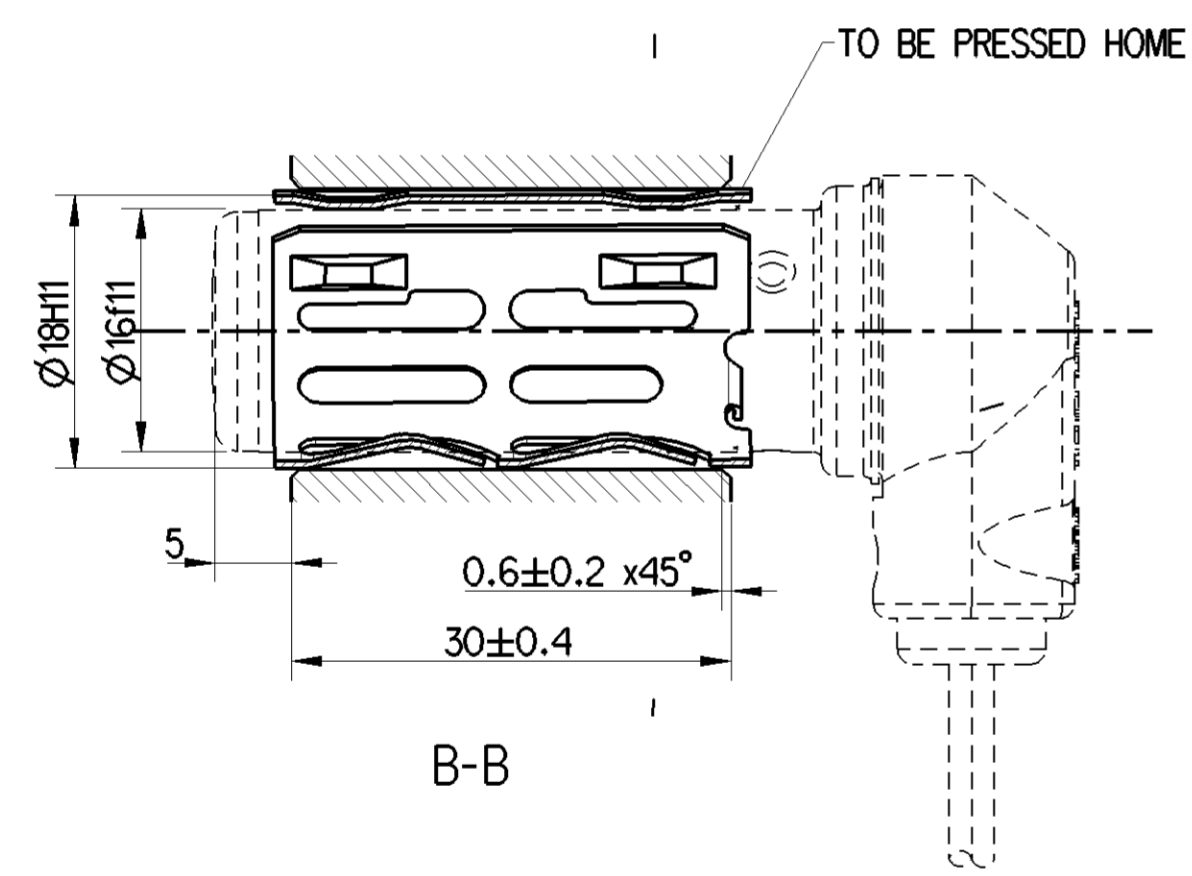

General Specification: JED-334-1, Size ISO 14405 LP		Copyright WABCO®		WABCO	
Further Technical Data:		Date	Signature		
Doc. Code: O35	Sheet: To	2020-09-18	Koojugodu	CLAMPING BUSH	
General Tolerances JED-261		Checked			
Range of Nominal Dimensions (± mm)		2020-09-18		Expert Nieber	
Class 1)	≤ 50 > 50 ≤ 180 > 180 ≤ 400 > 400	Nieber		Material No.	
Fine	0.5 1.0 1.5 2.0	Mass	Scale	894 501 001 4	
Medium	X 1.0 2.0 3.0 4.0	0.006 kg	2:1	Date of first issue: 2020-09-18	
Coarse	2.0 3.5 5.0 6.5	Size	CAD System	Doc. Code	Language
Tapped Holes acc. JED-152		A 2	CREO	005	EN
1) Tolerance Class Applied Crossmarked		ECON-No.		Revision	Techn. Resp.
		-		-	6310_EM
		Replacement for		/	

Non e permesso, concesso o terzi o riprodurre questo documento, ne utilizzare il contenuto o renderlo comunque noto a terzi senza autorizzazione esplicita. Ogni infrazione costituisce un evidente abuso e comporterà il risarcimento dei danni subiti. E' fatta riserva di tutti i diritti derivanti da brevetti o modelli.

Copying of this document and giving it to others and the use or communication of the contents thereof, are forbidden without express authority. Contravention of this restriction will constitute an evident abuse and result in a liability to the payment of damages. All rights are reserved in the event of the grant of patent or registration of a utility model or design. This document is the subject of copyright.

Tout communication ou reproduction de ce document, toute exploitation ou communication de son contenu sont interdites, sauf autorisation expresse. Tout manquement à cette règle constitue un abus évident et expose son auteur ou ses auteurs de dommages et intérêts. Tous droits de propriété industrielle réservés, notamment en matière de brevets et de modèles.

Wiedergabe sowie Vervielfältigung dieser Unterlagen, Verwertung und Mitteilung ihres Inhalts nicht gestattet, soweit nicht ausdrücklich zugestimmt. Zuwiderhandlungen stellen einen offensichtlichen Missbrauch dar und verpflichten zu Schadensersatz. Alle Rechte für den Fall der Patenterteilung oder Gebrauchsmuster-Erfindung vorbehalten.