

INSPECTION TEST STAMP
 PRUEFSTEMPEL
 MARQUE D'EPREUVE

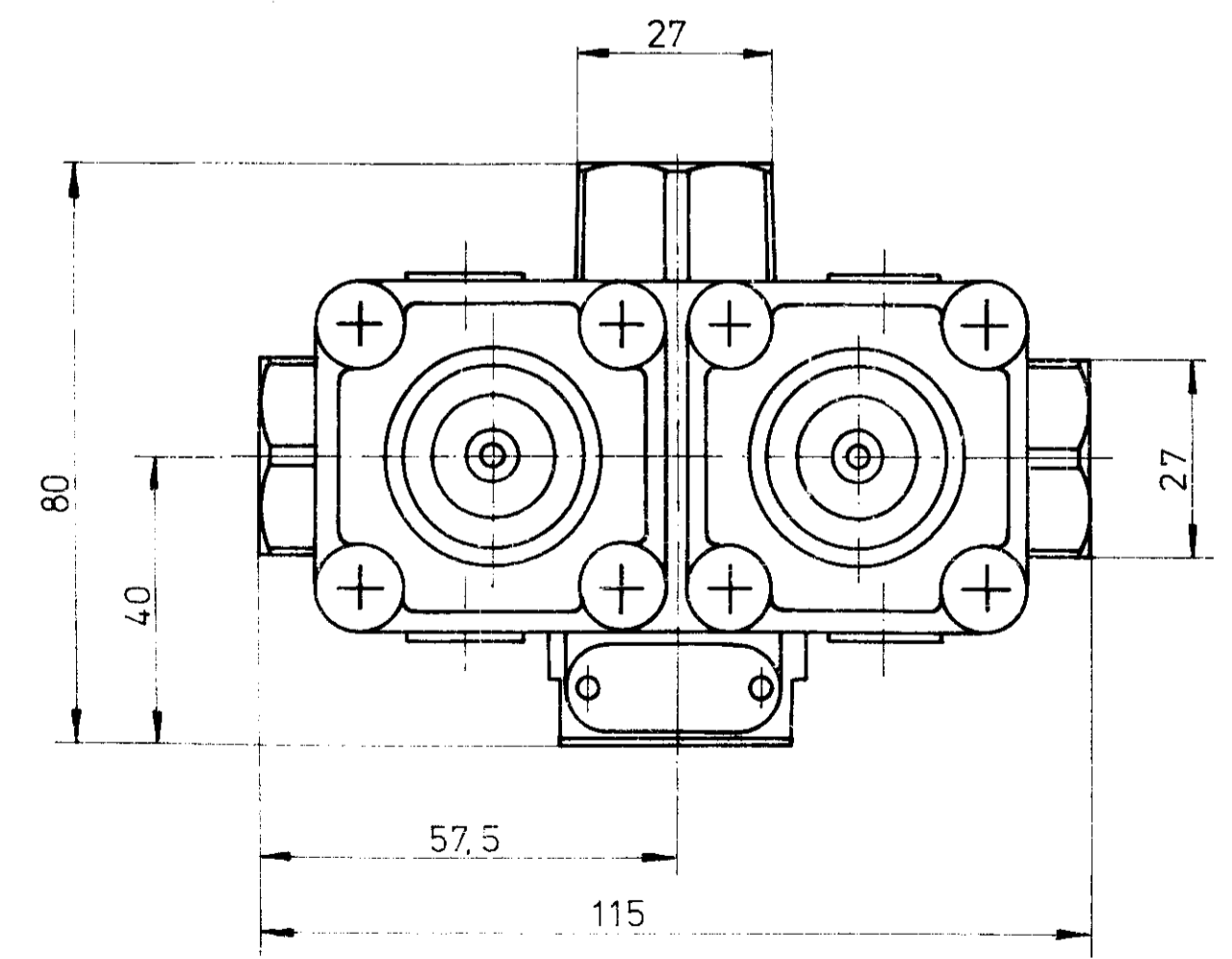
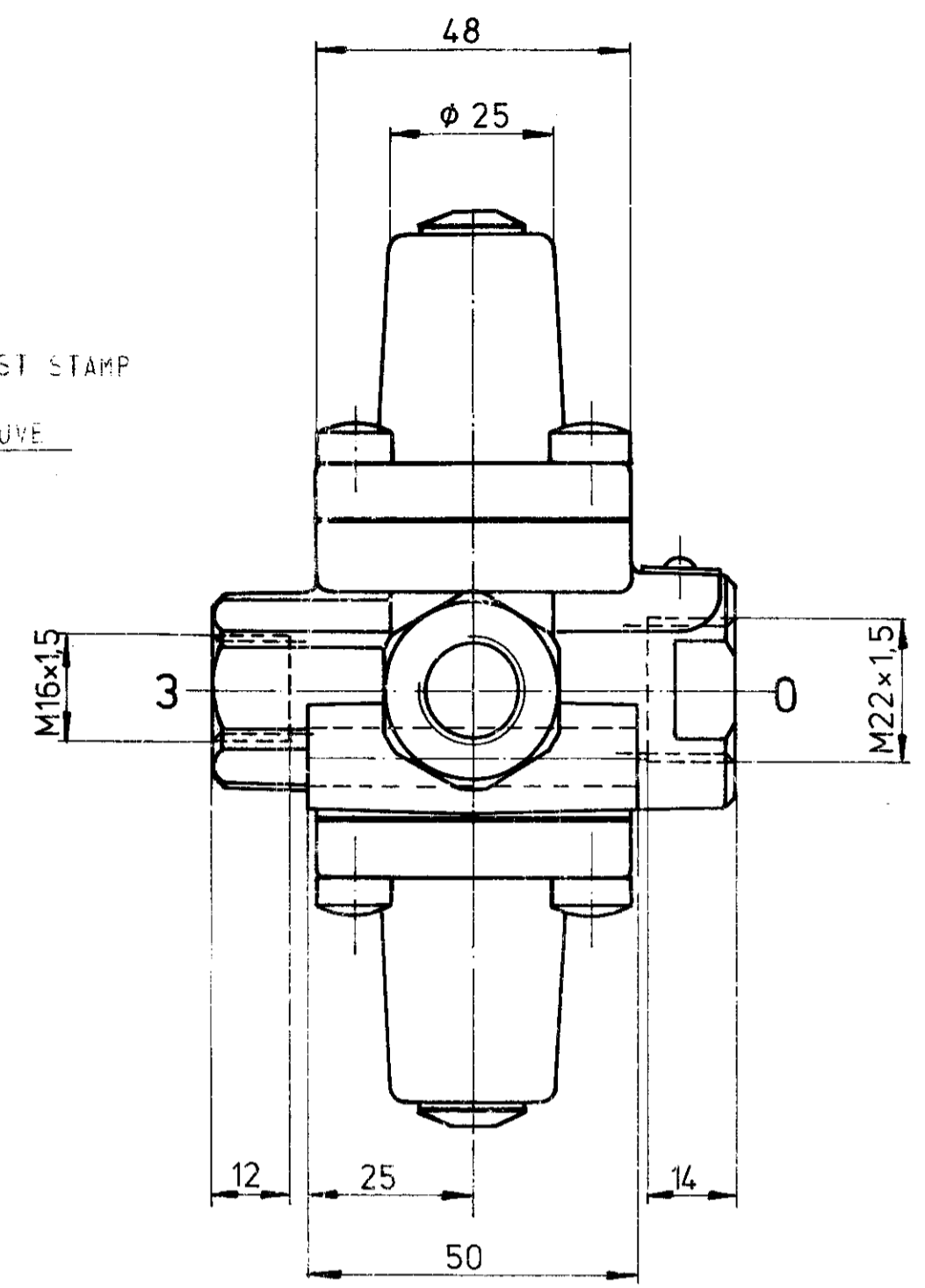

SERVICE PRESSURE:
 BETRIEBSDRUCK: MAX. 20 bar
 PRESSION DE SERVICE:
 PRESSIONE D'ESERCIZIO:

ADMISSIBLE TEMPERATURES:
 THERMISCHER ANWENDUNGSBEREICH: - 40°C +90°C
 TEMPERATURE DE SERVICE:
 TEMPERATURA D'ESERCIZIO:

MEDIUM: AIR
 MEDIUM: LUFT
 MILIEU: AIR
 FLUIDO: ARIA

WEIGHT:
 GEWICHT: 0,8 daN
 POIDS:
 PESO:

- CONNECTIONS: 0 = SUPPLY
 ANSCHLUESSE: 0 = LUFZEINTRITT
 ORIFICES: 0 = ALIMENTATION
 ORIFIZI: 0 = ALIMENTAZIONE
- 1 = CIRCUIT 1
 1 = KREIS 1
 1 = CIRCUIT 1
 1 = CIRCUITO 1
- 2 = CIRCUIT 2
 2 = KREIS 2
 2 = CIRCUIT 2
 2 = CIRCUITO 2
- 3 = CIRCUIT 3
 3 = KREIS 3
 3 = CIRCUIT 3
 3 = CIRCUITO 3

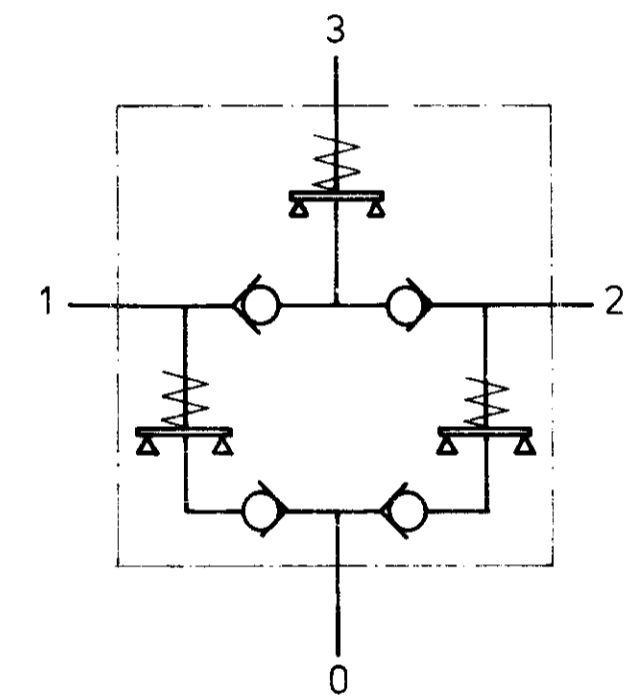

934 701 005 0	5,4-0,3 bar	5,4-0,3 bar	4,9-0,3 bar
934 701 004 0	6-0,3 bar	6-0,3 bar	5-0,3 bar
934 701 001 0	6-0,3 bar	6-0,3 bar	5,5-0,3 bar
934 701 000 0	5,7-0,3 bar	5,7-0,3 bar	5,2-0,3 bar

	CIRCUIT 1 KREIS 1 CIRCUIT 1 CIRCUITO 1	CIRCUIT 2 KREIS 2 CIRCUIT 2 CIRCUITO 2	CIRCUIT 3 KREIS 3 CIRCUIT 3 CIRCUITO 3
DEVICE NUMBER GERÄTE-NUMMER NUMERO D APPAREIL CODICE DELLO APPARECCHIO	OPENING PRESSURE GEFFENUNGSBRUCK PRESSION D'OUVERTURE PRESSIONE DI APERTURA		MAINTAINED PRESSURE GESICHERTER DRUCK PRESSION MANTENUE PRESSIONE MANTENUTA

13153 1x F 77-1024	Tolerances not specified Freimaßtoleranzen Tolérances générales Tolleranze generale	Material Werkstoff Matéria Materiale	Supplied as Lieferzustand Etat de livraison Stato di consegna
821 E 18.774		Surface protection Oberflächenschutz Protection Protezione	Mean value of roughness Ra in µm Mittelnrauhwert Ra in µm Valeur de la rugosité Ra en µm Valore della rugosità Ra in µm
788 D 6.274 C 2110.71	Scale Maßstab Echelle Scala	Treatment Behandlung Traitement Trattamento	Blank no. Rohteilnummer No. pièce brute No. pezzo grezzo

Revisions Änderungen Modifications Modifiche	16.7.71 Krauss	TRIPLE PROTECTION VALVE DREIKREIS-SCHUTZVENTIL VALVE DE PROTECTION VALVOLA DI PROTEZIONE	A934 701 000 0
Drawn	16.7.71 Krauss	WESTINGHOUSE JOINT ENGINEERING DEPARTMENT	Replacement for Ersatz für Remplace Sostituzione ORIG. OF 12.2.71 A2