

NON È PERMESSO CONSEGNARE, A TERZI O RIPRODURRE QUESTO DOCUMENTO, NE UTILIZZARE IL CONTENUTO O REPLICARLO, SENZA AUTORIZZAZIONE ESPlicitA, OGNI INFRAZIONE COSTITUISCE UN EVANTUALE REATO PENALE, IL RISARCIMENTO DEI DANNI SUBITI, E PUNTA AGENZIA DI TUTTI I DIRITTI DEVIANTI DA QUESTI DOCUMENTI. IL RISARCIMENTO DEI DANNI SUBITI, E PUNTA AGENZIA DI TUTTI I DIRITTI DEVIANTI DA QUESTI DOCUMENTI. IL RISARCIMENTO DEI DANNI SUBITI, E PUNTA AGENZIA DI TUTTI I DIRITTI DEVIANTI DA QUESTI DOCUMENTI.

NOU É PERMESSO CONSEGNARE, A TERZI O RIPRODUIRE CE DOCUMENT, NE UTILIZER LE CONTENU O REPLICAR, SANS AUTORIZZATION EXPlicITE, TOUS INFRACTIONS CONSTITUENT UN EVANTUEL REAU PENAL, LE RÉSARCISSEMENT DES DANNIS SUBIS, ET PUNTE AGENZIA DE TOUS LES DROITS DÉVIANT DE CE DOCUMENT.

NOU É PERMESSO CONSEGNARE, A TERZI O RIPRODUIRE CE DOCUMENT, NE UTILIZER LE CONTENU O REPLICAR, SANS AUTORIZZATION EXPlicITE, TOUS INFRACTIONS CONSTITUENT UN EVANTUEL REAU PENAL, LE RÉSARCISSEMENT DES DANNIS SUBIS, ET PUNTE AGENZIA DE TOUS LES DROITS DÉVIANT DE CE DOCUMENT.

NOU É PERMESSO CONSEGNARE, A TERZI O RIPRODUIRE CE DOCUMENT, NE UTILIZER LE CONTENU O REPLICAR, SANS AUTORIZZATION EXPlicITE, TOUS INFRACTIONS CONSTITUENT UN EVANTUEL REAU PENAL, LE RÉSARCISSEMENT DES DANNIS SUBIS, ET PUNTE AGENZIA DE TOUS LES DROITS DÉVIANT DE CE DOCUMENT.

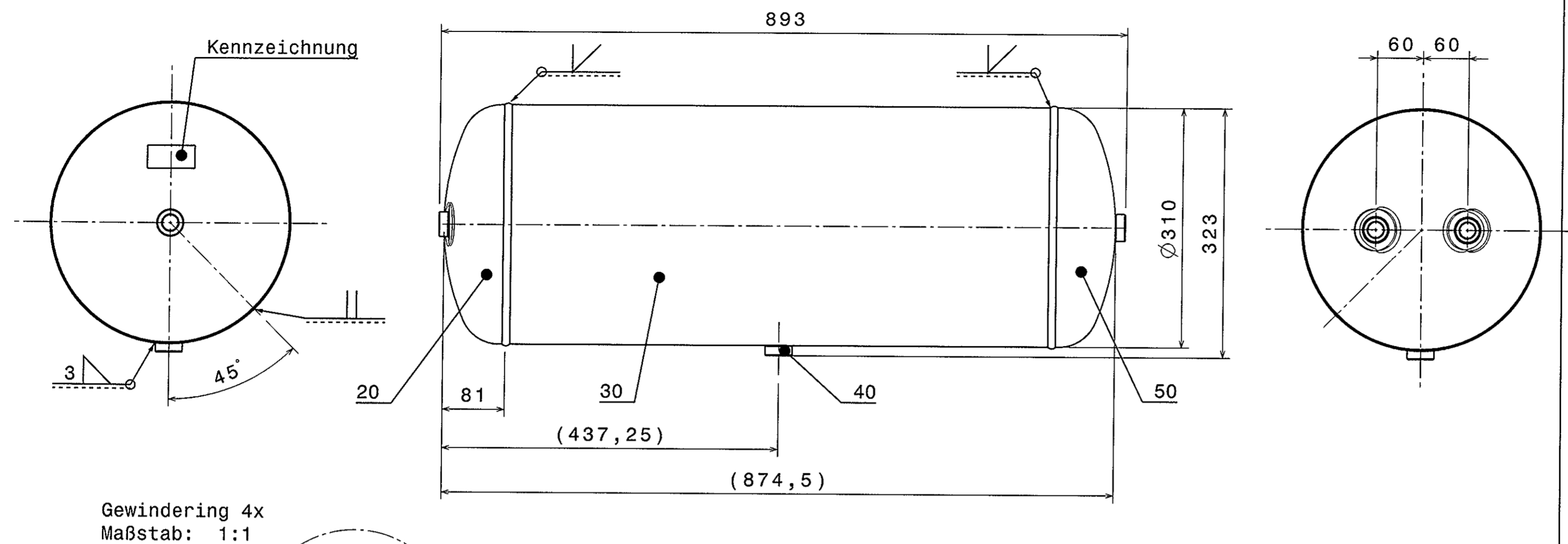

Gewinding 4x
Maßstab: 1:1

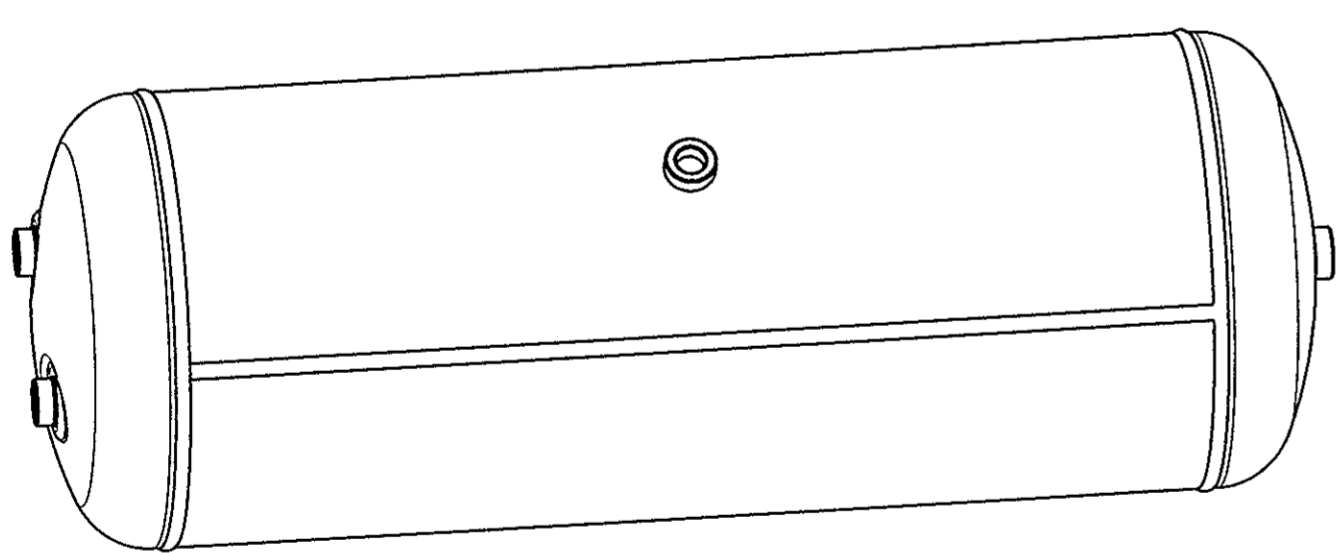
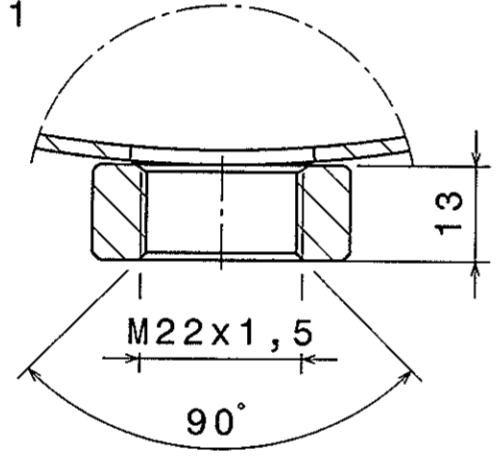

Kennzeichnung (marking)		Spezifikationen									
Etikett: (Pos. 10) Herstellerwerk		Regelwerk (norm/standard)	EN 286-2								
<div style="border: 1px solid black; padding: 5px;"> LinnemannSchnetzer Typ: WABCO 950 060 003 0 Typ: 114499 Serie: #-# Ind.:# Tmin/max: -50/100 °C V: 60,0 L Ps: 12,5 bar EN 286-2:1992 Baujahr: #### $\text{\textcircled{C}}$#### Jahreszahl Kennnummer der Prüfstelle </div>		Prüfdruck (test pressure)	Ph 1,5 x Ps bar								
		Berechnungsbeiwert (calc. correction value)	Kc 1								
		Wanddicke (wall thickness)	Smin 2,0/2,0 mm								
		Schweißverfahren (welding processes)		nach den gültigen Verfahrensprüfungen (in acc. with the valid process tests)							
		Oberflächenschutz (surface treatment)	innen (internal) Lack außen (external) PE-Pul.	rot-br min 25 µm schwarz min 60 µm	Pos.-Nr.: 90 Pos.-Nr.: 100						
An dieser Zeichnung sind alle Rechte vorbehalten. All rights are reserved for this drawing. Sie darf ohne unsere schriftliche Genehmigung Without our written permission you may not nicht vervielfältigt, weitergegeben oder deren copy this drawing or pass it on or make Inhalt dritten Personen zugänglich gemacht werden. its contents known to a third party. LinnemannSchnetzer, 59229 Ahlen (Westf.)											
Allgem. Toleranzangabe: EN ISO 13920-C		Maßstab: 1:5	Gewicht: ca. 15,2 kg								
<table border="1"> <thead> <tr> <th>Datum</th> <th>Name</th> </tr> </thead> <tbody> <tr> <td>Bearb. 06.05.2002</td> <td>Vöge</td> </tr> <tr> <td>Gepr. 06.05.2002</td> <td>Prinz</td> </tr> <tr> <td>Norm</td> <td></td> </tr> </tbody> </table>		Datum	Name	Bearb. 06.05.2002	Vöge	Gepr. 06.05.2002	Prinz	Norm		Material: P275SL, EN 10207 Werkzeugezeugnis EN 10204-2.2	
Datum	Name										
Bearb. 06.05.2002	Vöge										
Gepr. 06.05.2002	Prinz										
Norm											
Zust. Änderung LS Datum Name		Benennung: Druckluftbehälter (air pressure vessel)	Duchm.: 310 mm Volumen: 60,0 L Ps: 12,5 bar								
<div style="text-align: center;"> LINNEMANNSCHNETZER </div>		Zeichnungs-Nr.: 114499	Kunde: WABCO								
		Ers. f.: XXXXX	Kunden-Nr.: 950 060 003 0 EDV Nr.: 114499								

ORIGINAL-BLATTFORMAT: DIN A3

LINNEMANNSCHNETZER PART No. 114499

GENERAL SPECIFICATION: JED-334-0		Pro/ENGINEER DRAWING COPYRIGHT		<div style="text-align: center;"> WABCO AIR RESERVOIR LUFTBEHAELTER RESERVOIR D'AIR SERBATOIO D'ARIA </div>	
FURTHER TECHNICAL DATA:		DATE SIGNATURE			
DOC. CODE: SHEET: TO		DRAWN		19-Sep-02 J.M.Hall	
GENERAL TOLERANCES		CHECKED		28/02 N.TINKLER	
RANGE OF NOMINAL DIMENSIONS (± mm)		EXPERT CODE		319	
CLASS	1) ≤ 50	≤ 180	≤ 400	≤ 400	
FINE	0.5	1.0	1.5	2.0	±1°
MEDIUM	1.0	2.0	3.0	4.0	
COARSE	2.0	3.5	5.0	6.5	
TAPPED HOLES ACC. ISO 4039 / JED-152		302201	- D	17/09/02	
1) TOLERANCE CLASS APPLIED CROSSMARKED		DCN-NO.	REV.	DATE	
MASS SCALE		15.2	1:5	PRODUCT IDENTIFICATION NO.	
SIZE TRI		A 2	300	950 060 003 0	
FUNCTION CODE		5060	SHAPE CODE	PRODUCT TYPE	REPLACEMENT FOR
				003	

Dwg.: 9506000300 p4mrev ah7
 Mod.: MODEL NAME p4mrev