

SAFETY CHARACTERISTICS	0
SIGNIFICANT CHARACTERISTICS	2

! DANGER ENSURE EXTENSION LOCKING BEFORE INFLATING; ANY UNINTENDED DETACHMENT HAS TO BE PREVENTED
 VOR DRUCKBEAUFSCHLAGUNG GEWAHRLEISTEN, DASS DIE SCHLAUCHVERLAENGERUNG EINGERASTET IST UND SICH NICHT SELBSTTAETIG LOESEN KANN

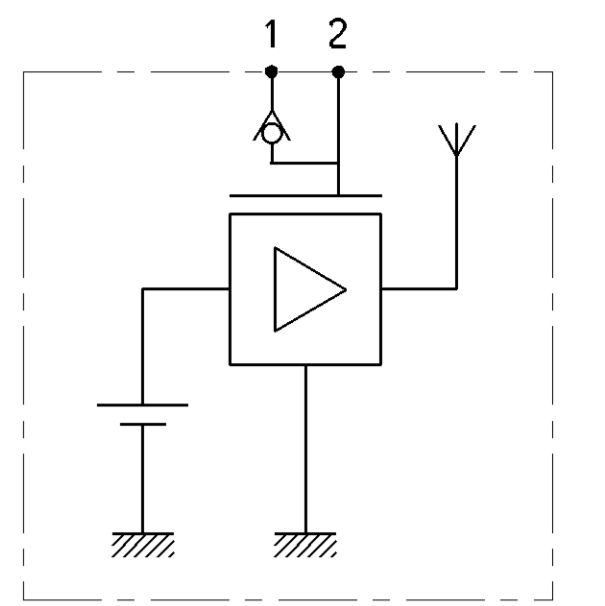
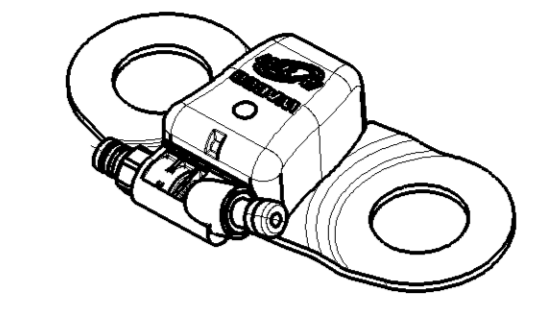

FUNCTIONAL SCHEME
FUNKTIONSDIAGRAMM

PRECISION GENAUIGKEIT	Temperature	0...+70°C	-20...0°C +70...+85°C	-40...-20°C +85...+125°C
	max FSO [%]	1.33	2	3.2

RF POWER SENDELEISTUNG	-12 dBm
TRANSMITTER FREQUENCY SENDEFREQUENZ	min 433.82MHz max 434.02MHz
THERMAL RANGE THERM. ANWENDUNGSBEREICH	-40 °C...+90 °C AND 120 °C - 24h
MEDIUM: MEDIUM:	AIR LUFT
EMC NUMBER: EMC NUMBER:	E1 10R-058164
MEASURING RANGE: DRUCK MESS BEREICH:	RELATIVE TO ATMOSPHERIC PRESSURE= 100kPa RELATIV ZUM ATMOSPHAERENDRUCK= 100kPa
DEGREE OF PROTECTION WITH EXTENSION SCHUTZART MIT VERLAENGERUNG	IP6K6K IP6K7 IP6K9K
FOR FURTHER TECHNICAL DATA SEE PRODUCT SPECIFICATION WEITERE TECHNISCHE DATEN SIEHE PRODUKT SPEZIFIKATION	960 731 990 0

1 LABEL, CONTENTS SEE DOCUMENT "LABELING INFORMATION"	960 731 071 0 (DOC. CODE 922)
2 PUSH-TO-CONNECT WITH PA-TUBE 6 X 1,5; PA12PHLY ONLY PUSH-TO-CONNECT NUR MIT PA-TUBE 6 X 1,5; PA12PHLY	

CONTAINS LITHIUM BATTERY ENTHAELT LITHIUM BATTERIE	Li CONTENT: 0,15g LITHIUM ANTEIL 0,15g
MATERIAL WERKSTOFF	SURFACE PROTECTION OBERFLAECHENSCHUTZ
JED-352-9	-
Fe JED-589-1	Zn/C JED-739-3 COLOUR SHADE: SILVER FARBTON : SILBER
STEEL STAHL	ZINC COATING ACCORDING TO JED-256-4 VERZINKUNG NACH JED-256-4
SELF-ADHESIVE FOIL/ SELBSTKLEBENDE FOLIE/ POLYESTER	-

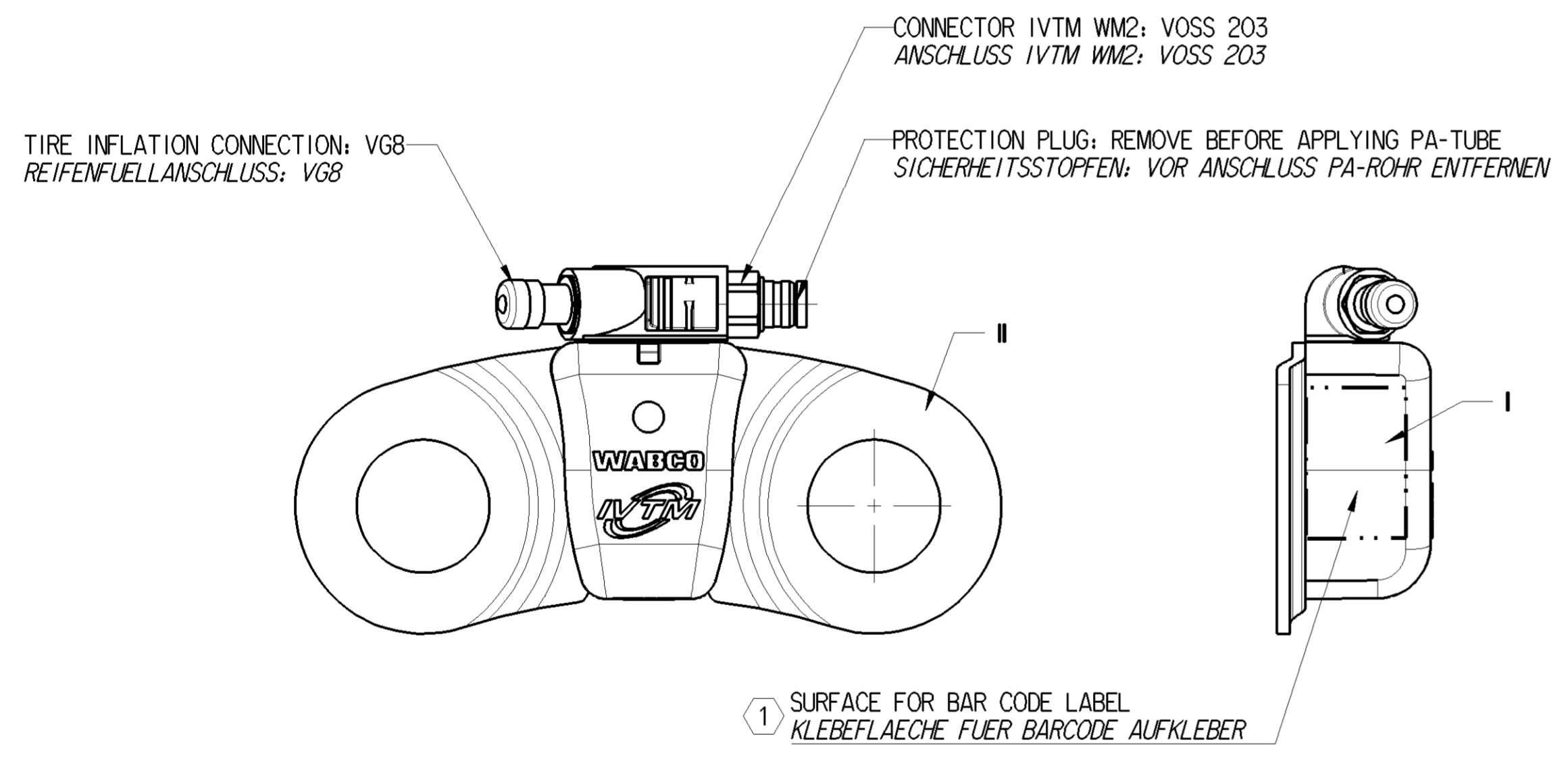
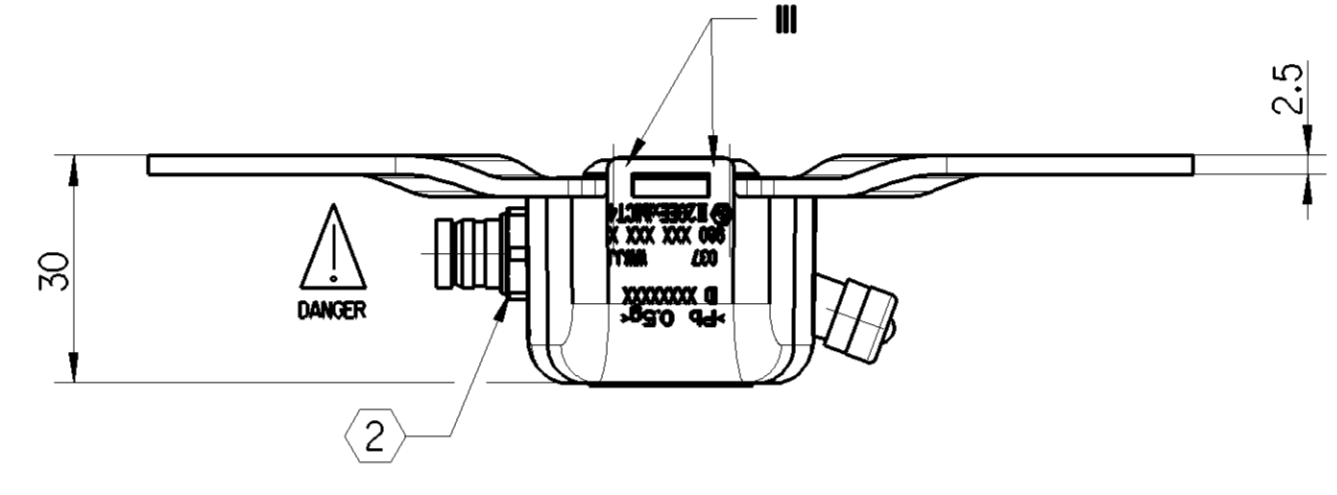
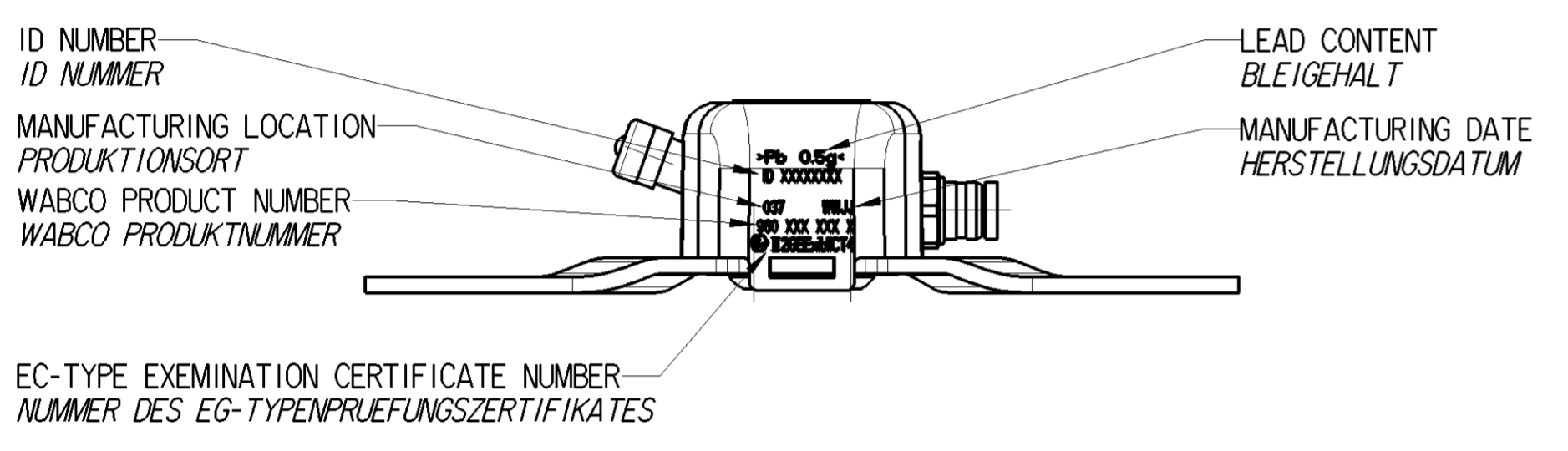

TORQUE ANZUGSMOMENT	FOR STEEL WHEELS: FUER STAHLRAEDER:	450-550 Nm
	FOR ALUMINIUM WHEELS: FUER ALUMINIUMRAEDER:	550-650 Nm
OR ACCORDING TO THE MANUFACTURER'S SPECIFICATIONS BZW. GEMAESS HERSTELLERANGABE		

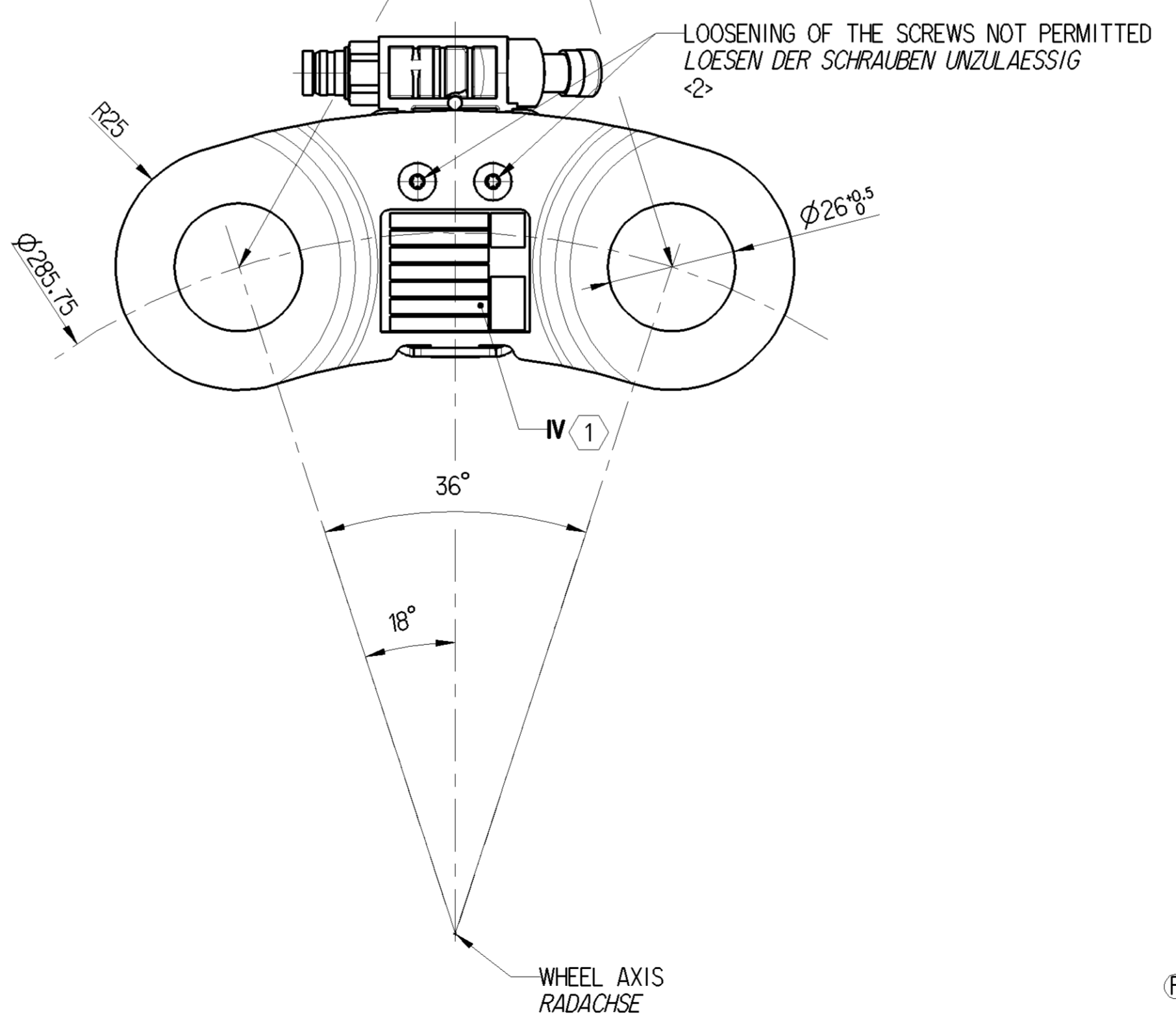

General Specifications: JED-334-1 ISO 14405 LP		Copyright WABCO®	
Further Technical Data:		Date: 2017-02-14	Signature: Markuszewski
Doc. Code:	Sheet: To:	Checked: Cornelius	Expert: CORNELIUS
General Tolerances JED-261		Mass: 0.23 kg	Scale: 1:1
Range of Nominal Dimensions (± mm)		Size: A 1	Material No.: 960 731 071 0
Class	1) 1) 1) 1) 1)	System: CREO	Date of first issue: 2008-03-10
Fine	0.5 1.0 1.5 2.0	Revision: 7x	Doc. Code: 005
Medium	1.0 2.0 3.0 4.0	Techn. Resp.: F	Language: DE
Coarse	2.0 3.5 5.0 6.5	Replacement for: 6033	Sheet: 1/1
Tapped Holes acc. JED-152		11) Tolerance Class Applied Crossmarked	

Non e permesso copiare o riprodurre questo documento, ne utilizzare o copiarlo in modo contrario a quanto indicato in esso.
 Toute reproduction ou reproduction de ce document, toute exploitation ou communication de son contenu sans autorisation, sont interdites.
 Copia di questo documento e' vietata, e' vietato l'uso o la comunicazione del suo contenuto senza permesso scritto dalla WABCO.
 Wabco sowie Vertriebspartner dieser Unterlage, Verwertung und Mitteilung ihrer Inhalte nicht gestattet, soweit nicht anders angegeben.
 All rights reserved. No part of this publication may be reproduced, stored in a retrieval system, or transmitted in any form or by any means, electronic, mechanical, photocopying, recording, or by any information storage and retrieval system, without the prior written permission of WABCO.