

THE LOCKING DEVICE MUST AUTOMATICALLY AND SAFETY LOCK THE HANDLE IN THE PARKING POSITION
 <-> DIE VERRASTUNG MUSS DEN HEBEL AUTOMATISCH UND SICHER IN DER PARKPOSITION HALTEN
 LA BUTEE DOIT VERROUILLER AUTOMATIQUEMENT ET DE FACON SECURISEE LA POIGNEE EN POSITION PARKING

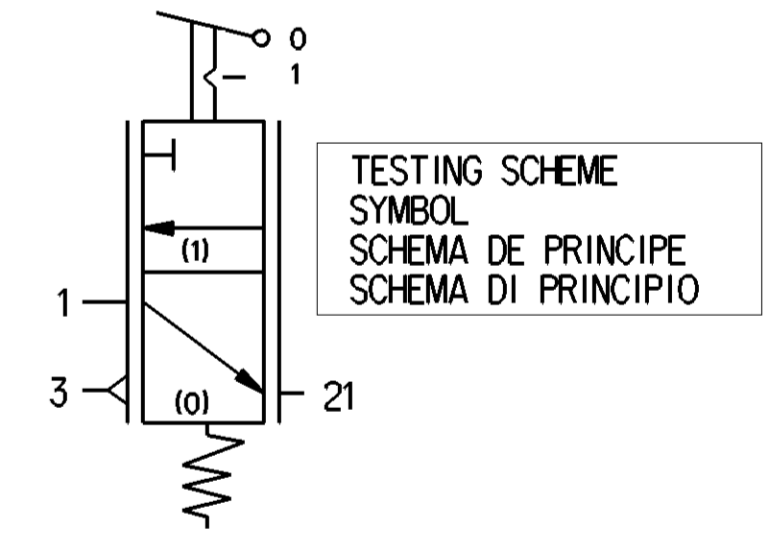
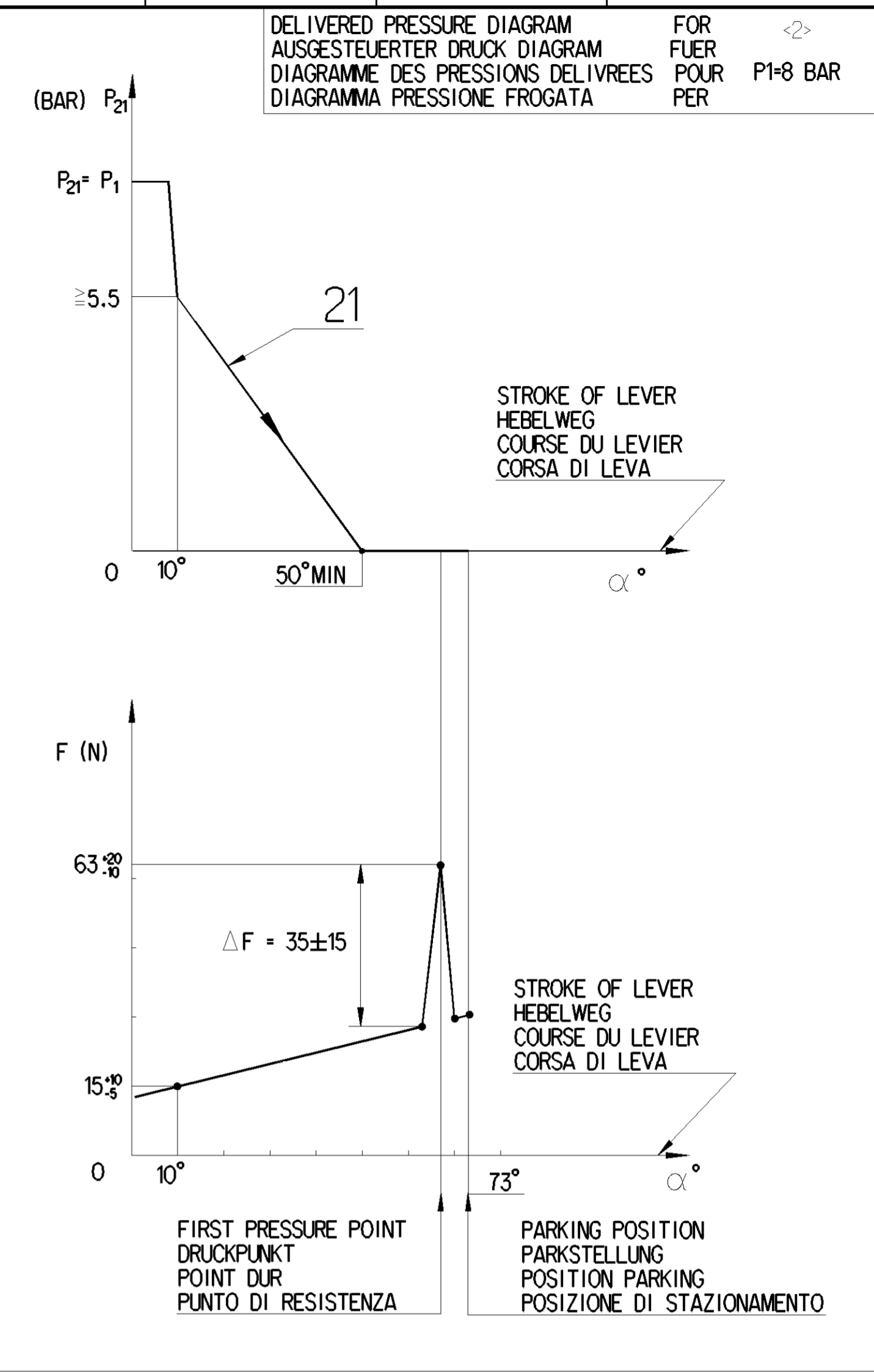
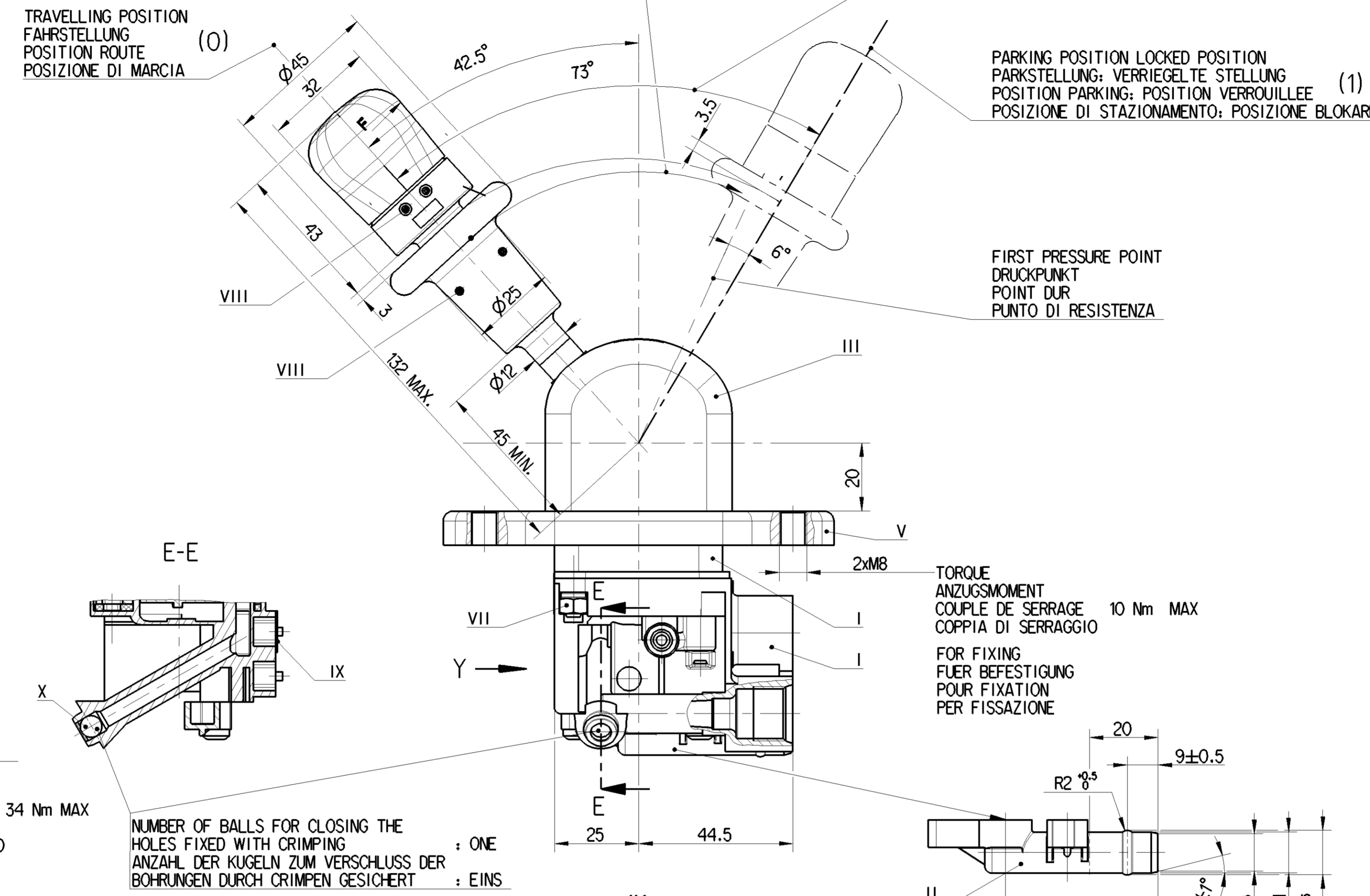
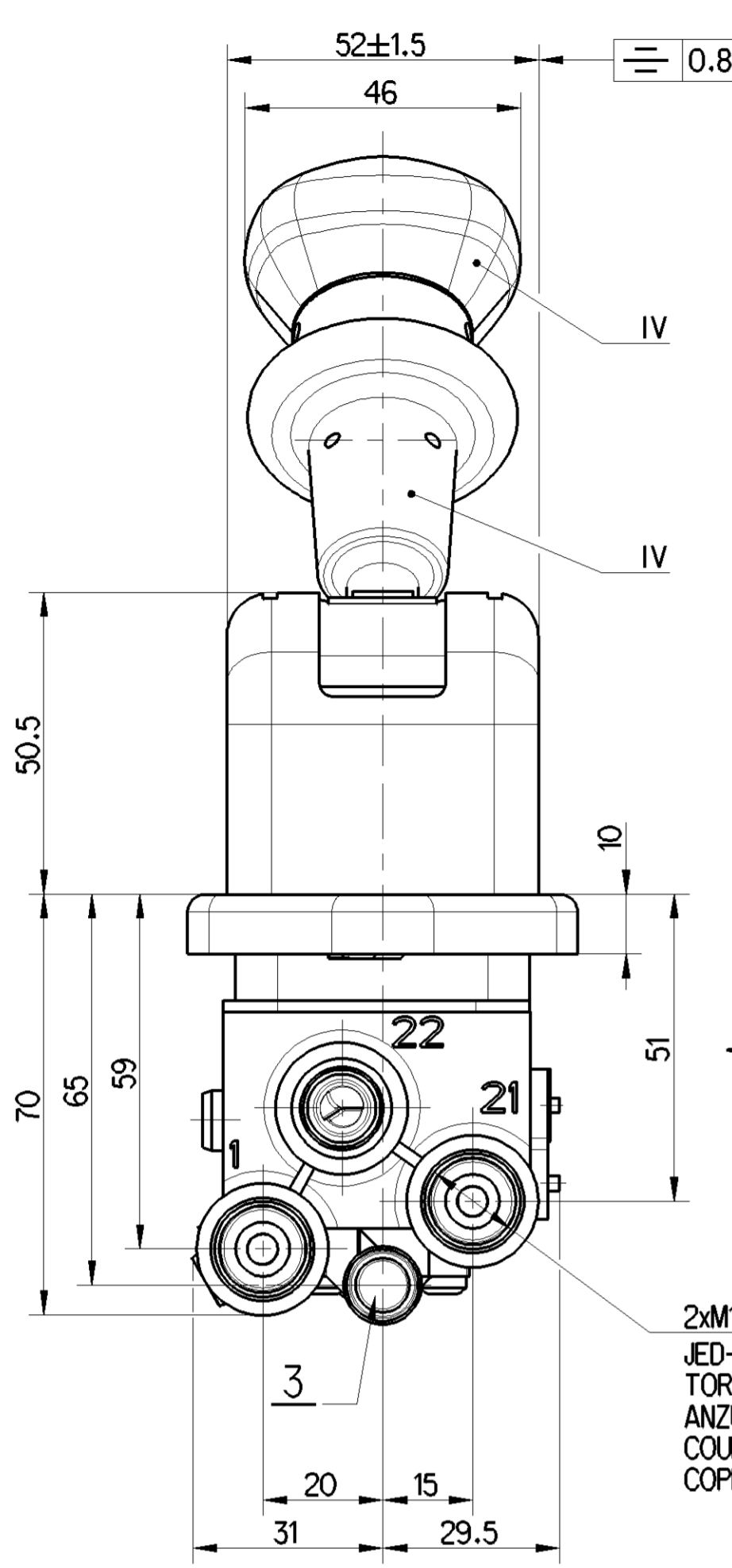

SAFETY CHARACTERISTICS	1
SIGNIFICANT CHARACTERISTICS	1

1	SPECIFIC CUSTOMER LABEL SPEZIFISCH KUNDENETIKETT SPECIFIQUE ETIQUETTE DU CLIENT SPECIFICA ETICHETTA DEL CLIENTE
1	SUPPLY VORRAT ALIMENTATION ALIMENTAZIONE
21	SPRING BRAKE CYLINDER FEDERSPEICHERZYLINDER CYLINDRE A RESSORT CILINDRO A MOLLA
3	EXHAUST ENTLUEFTUNG ECHAPPEMENT SCARICO
	MEDIUM: AIR MEDIUM: LUFT FLUIDE: AIR FLUIDO: AIRIA
	THERMICAL RANGE THERMISCHER ANWENDUNGSBEREICH TEMPERATURE D'UTILISATION TEMPERATURA DI UTILIZZAZIONE -40°C - +80°C
	SUPPLY PRESSURE VORRATSDRUCK PRESSION PNEUMATIQUE D'ALIMENTATION PRESSIONE PNEUMATICA DI ALIMENTAZIONE P1=10 BAR MAX

	MATERIAL MATERIAL MATIERE MATERIALE	SURFACE PROTECTION OBERFLÄCHENSCHUTZ PROTECTION DE SURFACE
I	JED-004M / Zn	JED-260 / (Passivation of Zn alloy)
II	JED-005M2 / POM	
III	JED-776-1 / PC+ABS	
IV	AKULON S240C / PA 6.6	
V	JED-029M3 / Al	JED-259 / (Passivation of Al alloys)
VI	JED-679-0 / Carbon steel	JED-206-0 / (Passivation, Zn-Steel)
VII	JED-051M2 / Unalloyed steel	JED-257 / (Passivation, Zn alloy-Steel)
VIII	JED-061M0 / Stainless steel	
IX	JED-077-1 (JED-621 optional) / Al	JED-007-1 (Anodic oxidation)
X	JED-619 / Stainless steel	

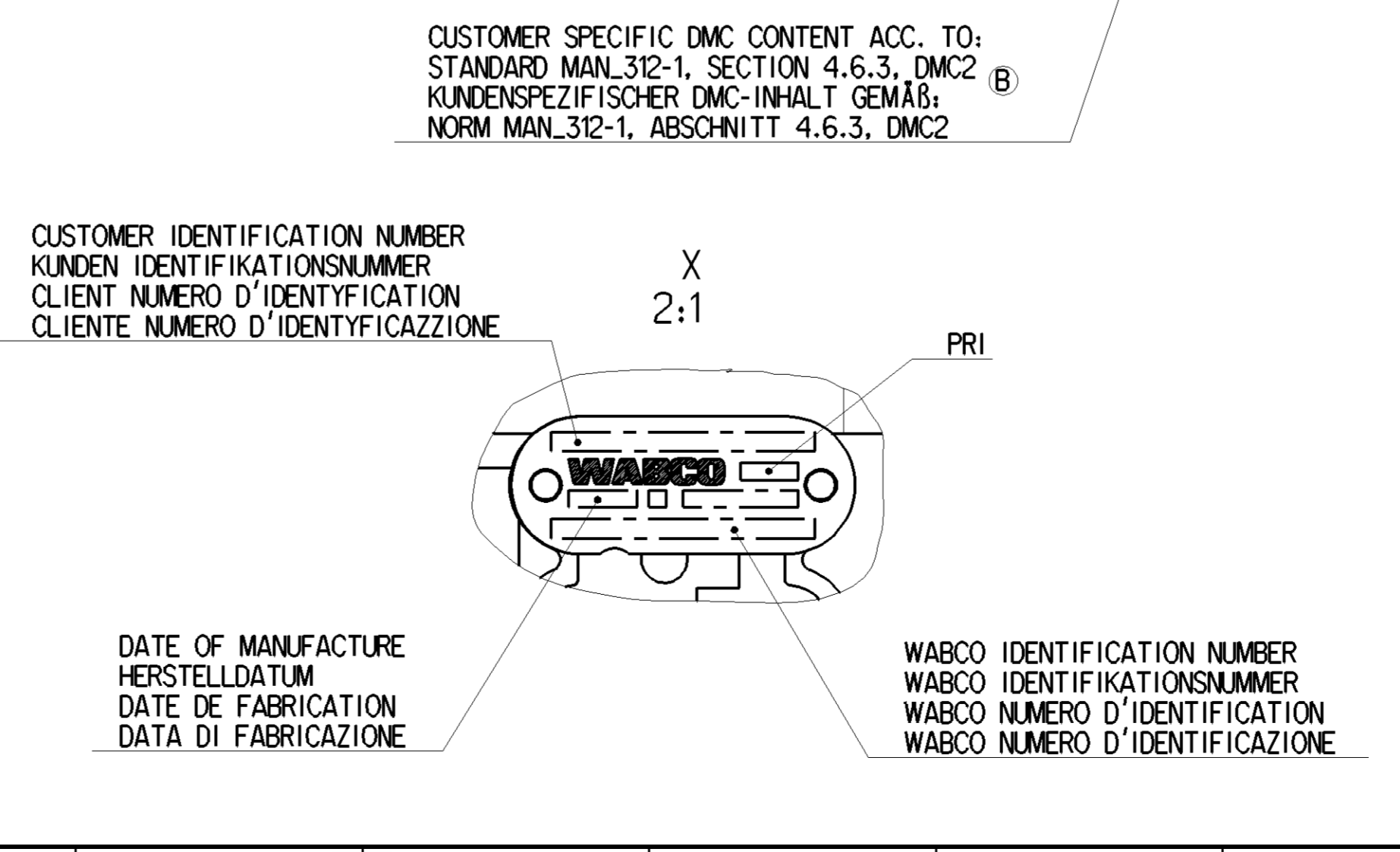

CODE FORMAT: -XXXX
 (XXXX -> LAST 4 DIGITS OF MAN PART NUMBER)
 CODE-FORMAT: -XXXX
 (XXXX -> DIE LETZTEN 4 STELLEN DER MAN-TEILENUMMER)

WORD MARK ACC. TO: STANDARD M 3000
 SECTION 4, TYPE 4
 TEXTKENNZEICHNUNG GEMÄß: NORM M 3000
 ABSCHNITT 4, TYP 4

CUSTOMER SPECIFIC DMC CONTENT ACC. TO:
 STANDARD MAN_312-1, SECTION 4.6.3, DMC2
 KUNDENSPEZIFISCHER DMC-INHALT GEMÄß:
 NORM MAN_312-1, ABSCHNITT 4.6.3, DMC2

DATE OF MANUFACTURE
 HERSTELLDATUM
 DATE DE FABRICATION
 DATA DI FABRICAZIONE

WABCO IDENTIFICATION NUMBER
 WABCO IDENTIFIKATIONSNUMMER
 WABCO NUMERO D'IDENTIFICAZIONE
 WABCO NUMERO D'IDENTIFICAZIONE

General Specification: JED-334-1, Size ISO 14405 LP
 Further Technical Data: Product Specification 961 723 037 0
 Doc. Code: 035 Sheet: 1 To 5

Copyright WABCO®
 Date: 2017-09-13
 Drawn: Zubięgo
 Checked: Swiatek
 Expert: Swiatek

WABCO
 HAND BRAKE VALVE
 HANDBREMSVENTIL
 ROBINET DE FREINAGE A MAIN
 ROBINETTO DI COMANDO A MANO

Mass	0.81 kg	Scale	1:1 (2:1)
Size	A 1	CREO	174684
Material No.	961 723 037 0	Revision	9x B
Date of first issue:	2003-04-03	Techn. Resp.	5211
Doc. Code	005	Language	ML
Sheet	1/1	Replacement for	

1) Tolerance Class Applied Crossmarked

Non è permesso copiare o riprodurre questo documento, né utilizzare il contenuto a fini commerciali, senza permesso scritto dalla WABCO. Toute réimpression ou communication de son contenu sans autorisation écrite de la WABCO est formellement interdite. All rights reserved. No part of this document may be reproduced, stored in a retrieval system, or transmitted in any form or by any means, electronic, mechanical, photocopying, recording, or by any information storage and retrieval system, without the prior written permission of WABCO.