

MATERIAL MATERIAL		SURFACE PROTECTION OBERFLAECHENSCHUTZ	
I	Fe JED-051M4	Zn/C	JED-256-1
II	Al JED-029M1	Cr	JED-259-1
III	PA6.6 JED-354-1		
IV	Al JED-077-1	⑧	JED-007-1
V	CuZn JED-035M1		

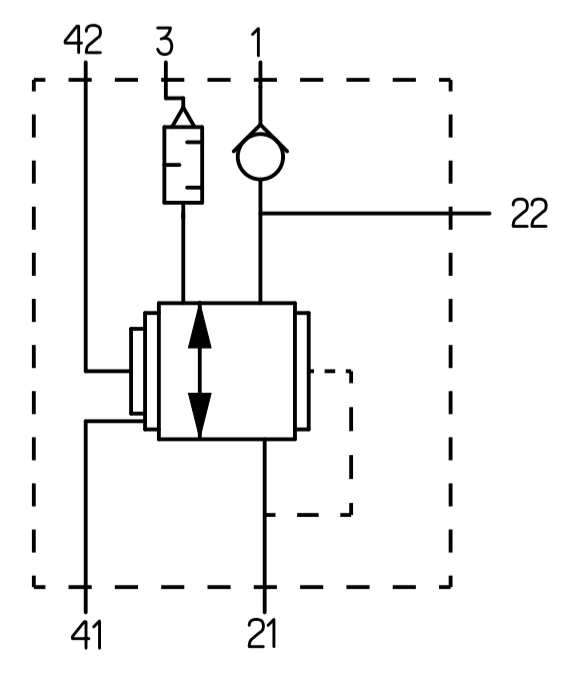

MEDIUM MEDIUM		AIR LUFT	
WORKING PRESSURE BETRIEBSDRUCK		MAX. $p_e = 10$ BAR	TEMPORARY KURZZEITIG
THERMAL RANGE OF APPLICATION THERMISCHER ANWENDUNGSBEREICH		-40° ... +80°C	
TYPE OF PROTECTION SCHUTZART		COMPLETE DEVICE WITH MOUNTED COUPLING KOMPLETTES GERAET MIT MONTIERTER KUPPLUNG	IP 6K9K
SUPPLY PRESSURE VORRATSDRUCK		MAX. $p_e = 13$ BAR	
PERMISSIBLE INSTALLATION ZULAESSIGE EINBAULAGE		±90°	
1	SUPPLY VORRAT		
21	DELIVERY PRESSURE AUSGESTEUERTER DRUCK		
22	OUTPUT SUPPLY AUSGANG VORRAT	$p_{22} = p_1 - \Delta p$	
3	EXHAUST / VENTILATION ENTLUEFTUNG / BEATMUNG		
41/42	CONTROL PRESSURE STEUERDRUCK	$p_e = \text{max. } 11$ bar	TEMPORARY KURZZEITIG
TORQUE FOR CONNECTIONS: ANZUGSMOMENT FUER EINSCHRAUBSTUTZEN:		M16x1.5	M22x1.5
		Max. 34Nm	Max. 53Nm
③	MANUFACTURING PLANT PRODUKTIONSSTAETTE		JED-225
④	WEEK / YEAR OF MANUFACTURE FERTIGUNGSWOCHE / -JAHR		
⑤	WABCO-DEVICE NUMBER WABCO-GERAETE NUMMER		
⑥	CUSTOMER NO. / ZGS KUNDEN-NR. / KZ / ZG		
⑦	DMC CODE AREA DMC BEREICH		
⑧	ANODIC OXIDATION ANODISCHE OXIDATION		

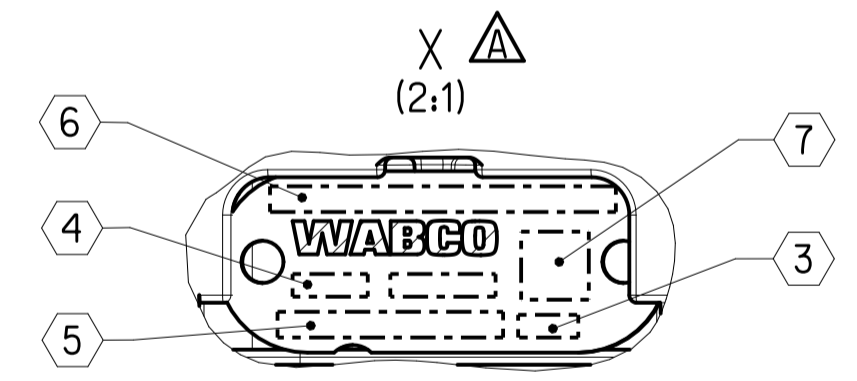
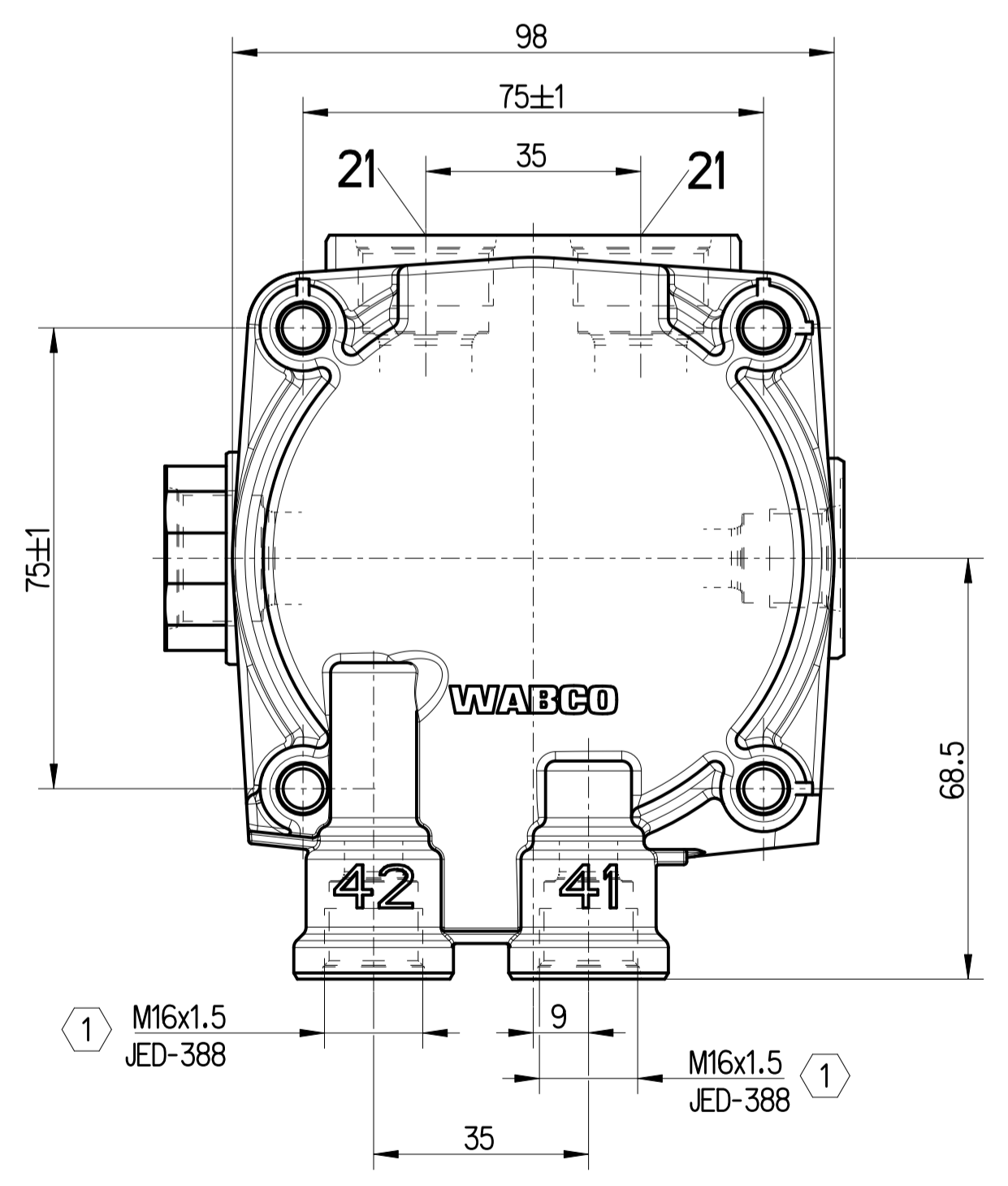
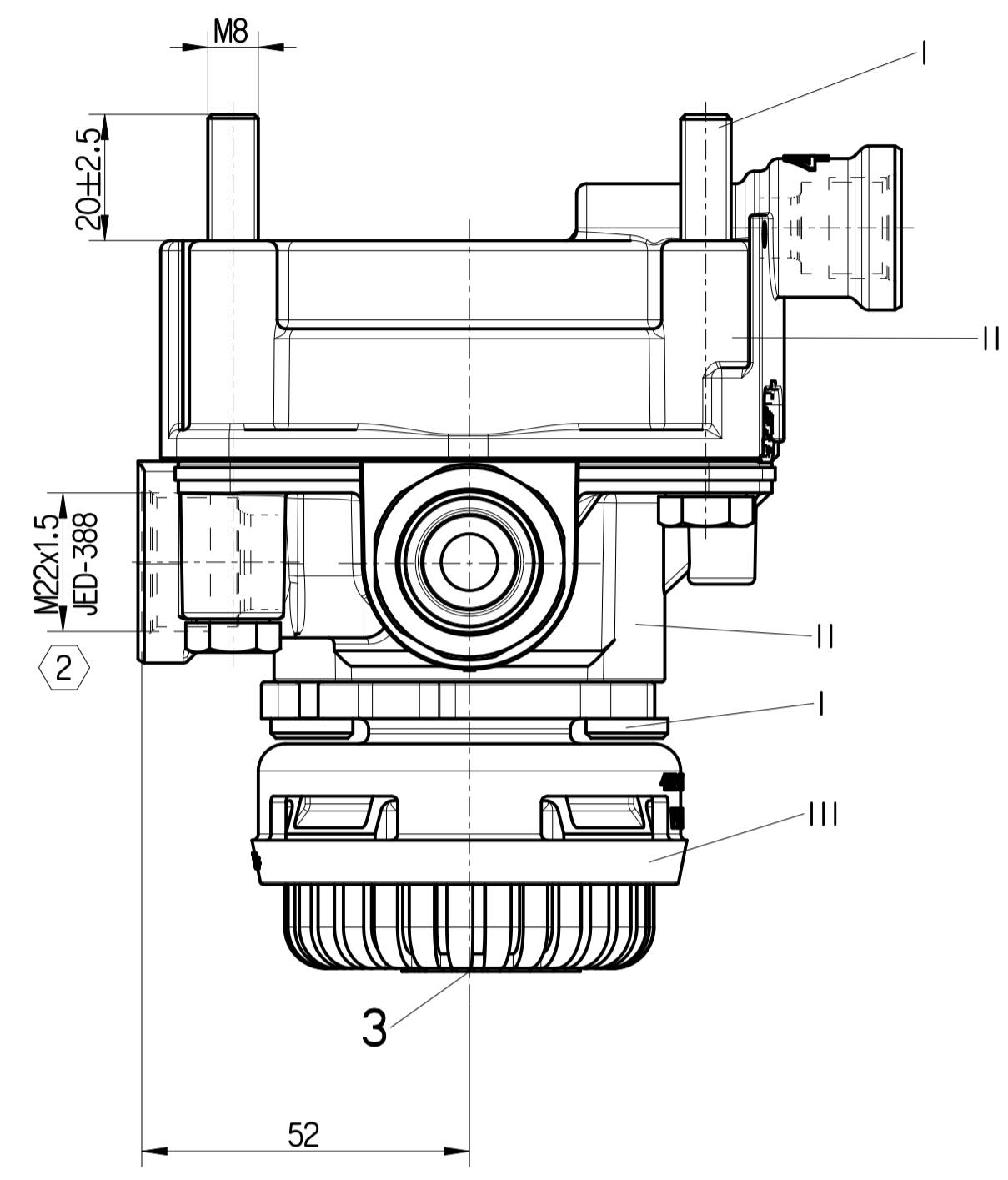
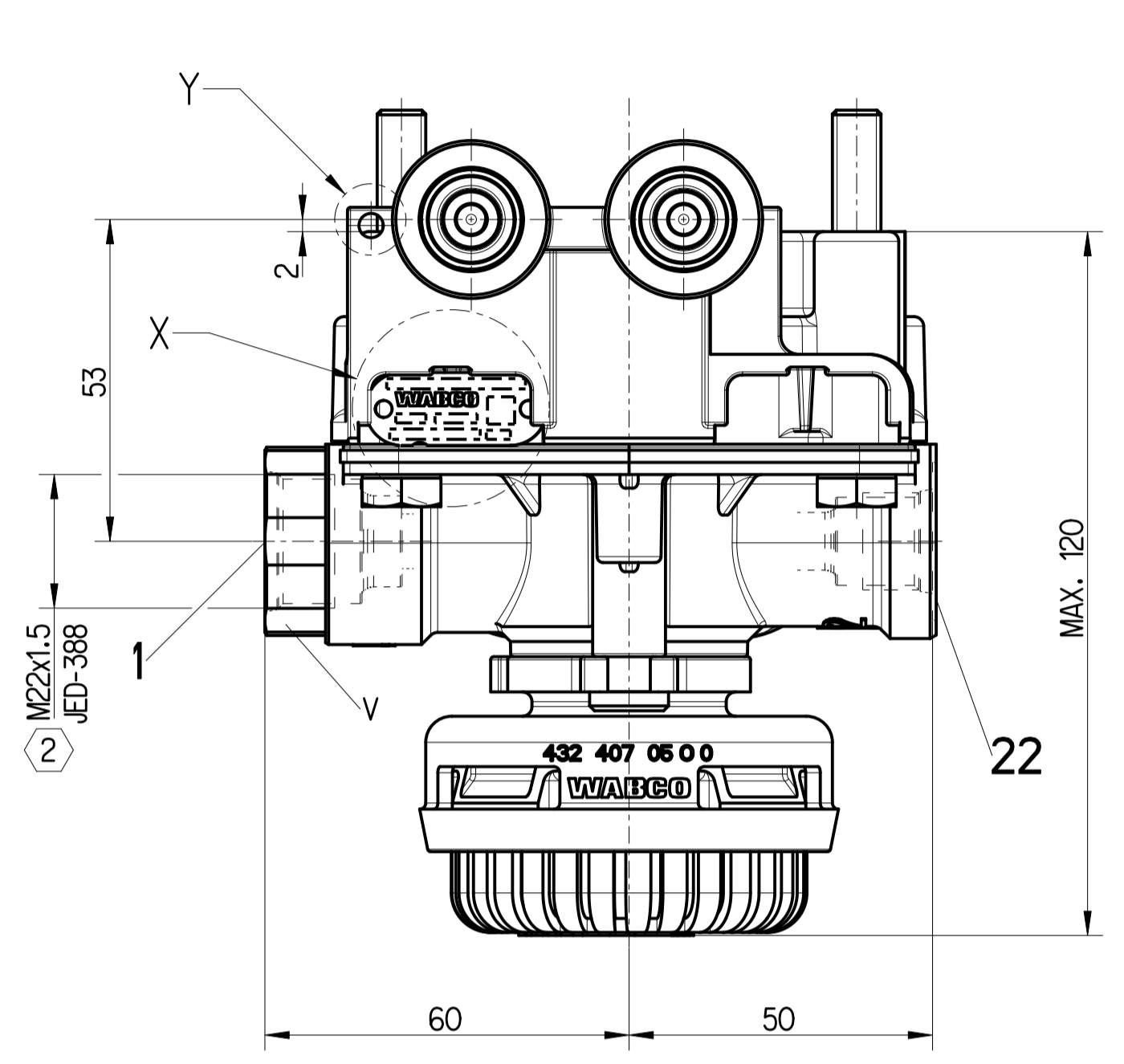
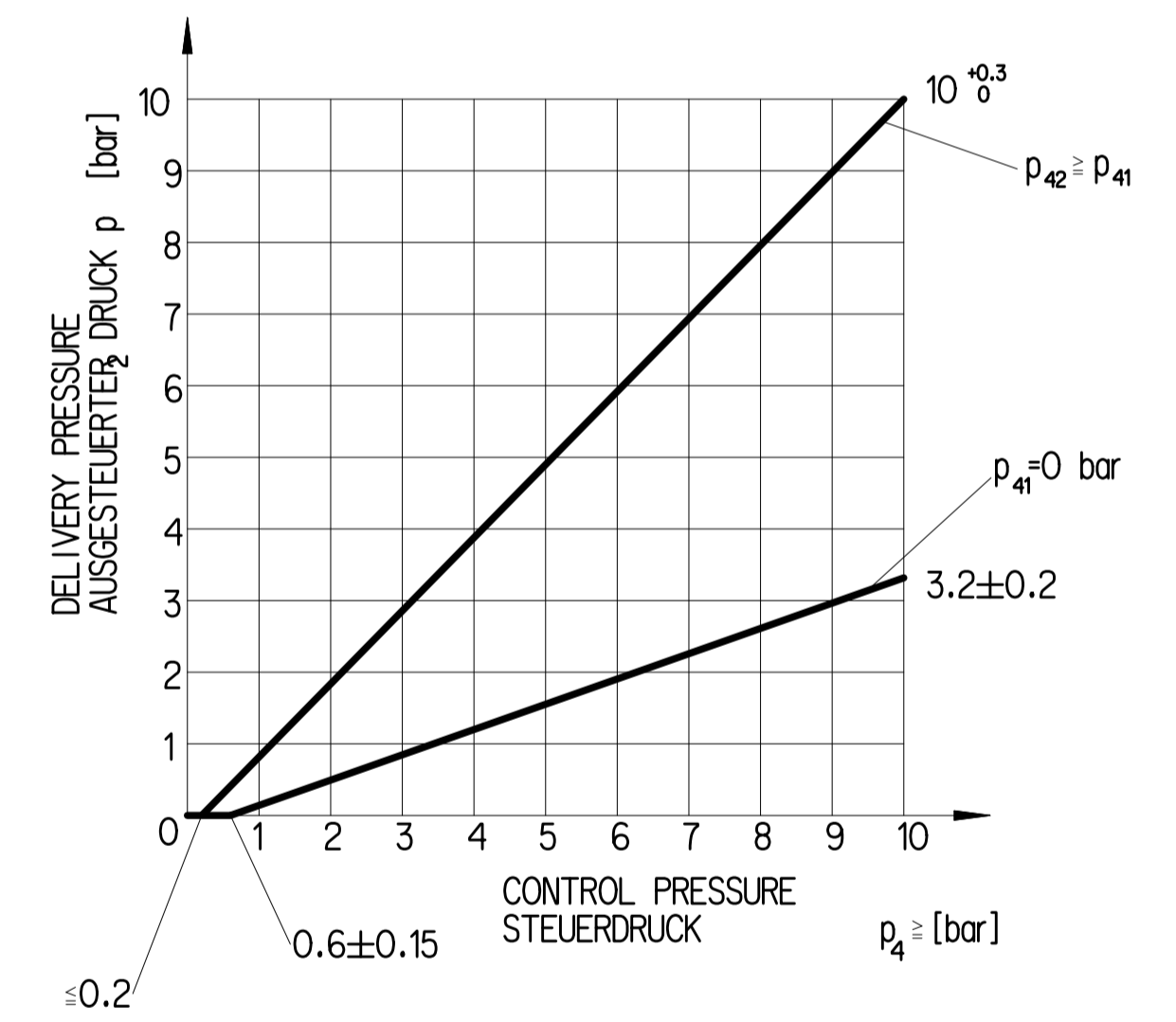

General Specifications: ISO 8075, JED-334-1, Size ISO 14405 LP

Copyright ZF®

Doc. Code: 2025-11-04

Sheet: 3 of 3

General Tolerances JED-261

Class	1)	≤ 50	> 50	> 180	> 400
Fine		±0.5	±1	±1.5	±2
Medium	X	±1	±2	±3	±4
Coarse		±2	±3.5	±5	±6.5

Dimensions in mm

Mass: 1.1 kg

Scale: 1:1 (2:1)

Size: CAD System

Material No.: 973 011 251 0

ECN-No.: 516312

Revision: 3 x A

Techn. Resp.: 5220

Date of first issue: 2025-11-05

Doc. Code: Language: Sheet: 005 ML 1/1

Replacement for:

Tutti i diritti sono riservati. È vietata espressamente la ristampa o l'uso non autorizzato senza permesso scritto dalla ZF. È vietata espressamente la ristampa o l'uso non autorizzato senza permesso scritto dalla ZF. È vietata espressamente la ristampa o l'uso non autorizzato senza permesso scritto dalla ZF. È vietata espressamente la ristampa o l'uso non autorizzato senza permesso scritto dalla ZF.