

<P>	SAFETY CHARACTERISTICS	0
<S>	SIGNIFICANT CHARACTERISTICS	0

Sl.No.	NOTES	
1.	WORKING MEDIUM	AIR
2.	NORMAL WORKING PRESSURE	8.5 bar
3.	MAXIMUM WORKING PRESSURE	10 bar
4.	NOMINAL FLOW DIAMETER	10 mm
5.	THERMAL RANGE OF OPERATION	-40°C TO +80°C
6.	CORROSION RESISTANCE	96 HOURS OF NSS.
7.	USAGE	CONTROL LINE
8.	TORQUE FOR HOSE CONNECTIONS	31 ± 3 Nm
9.	DESIGN COMPLIES WITH	ISO 1728-2006
10.	PRODUCT SPECIFICATION No	PS PRO2002210

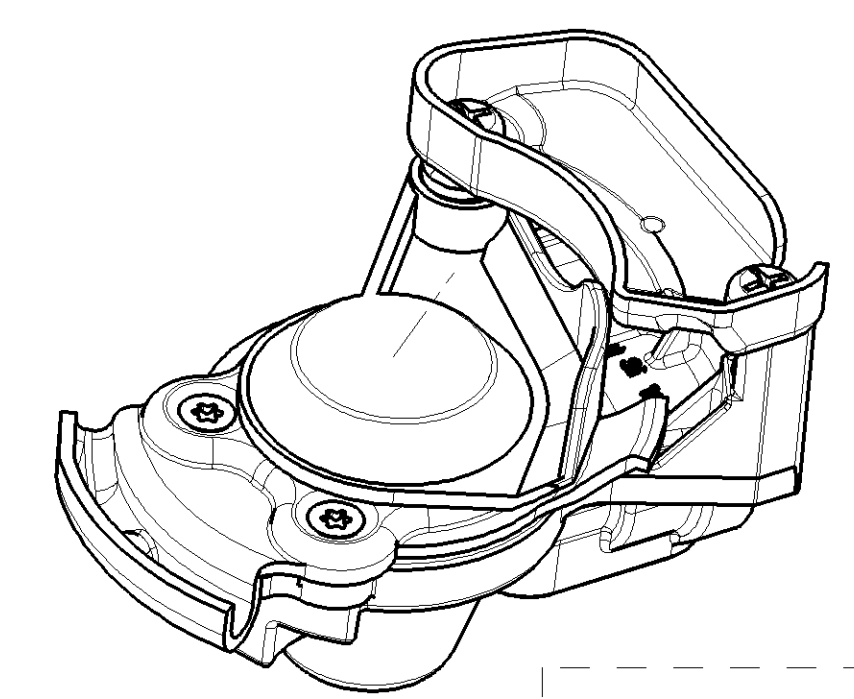
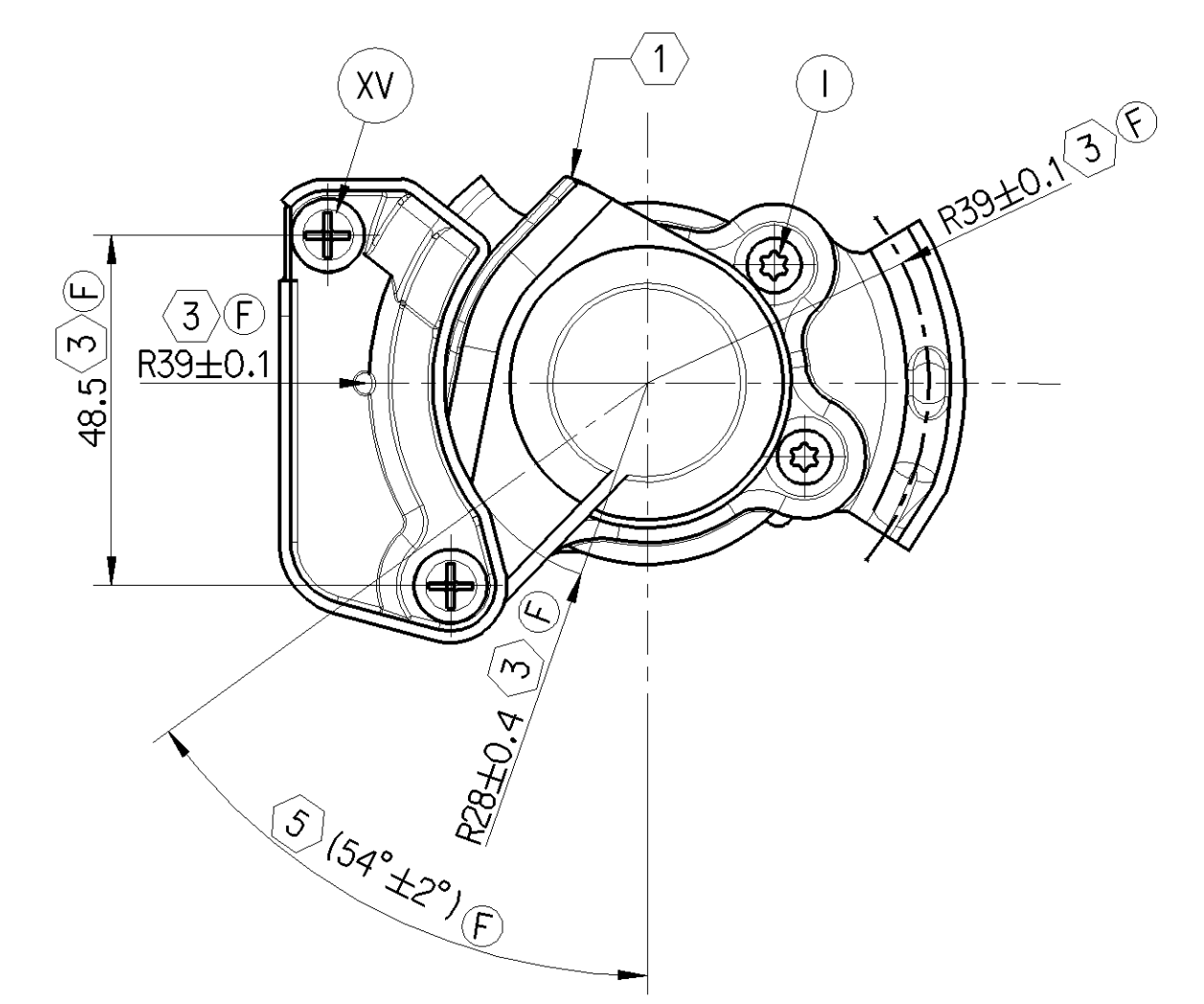
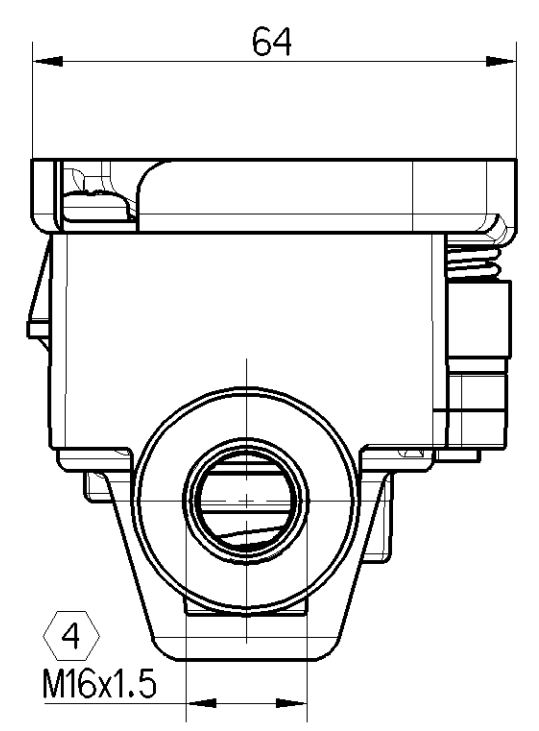
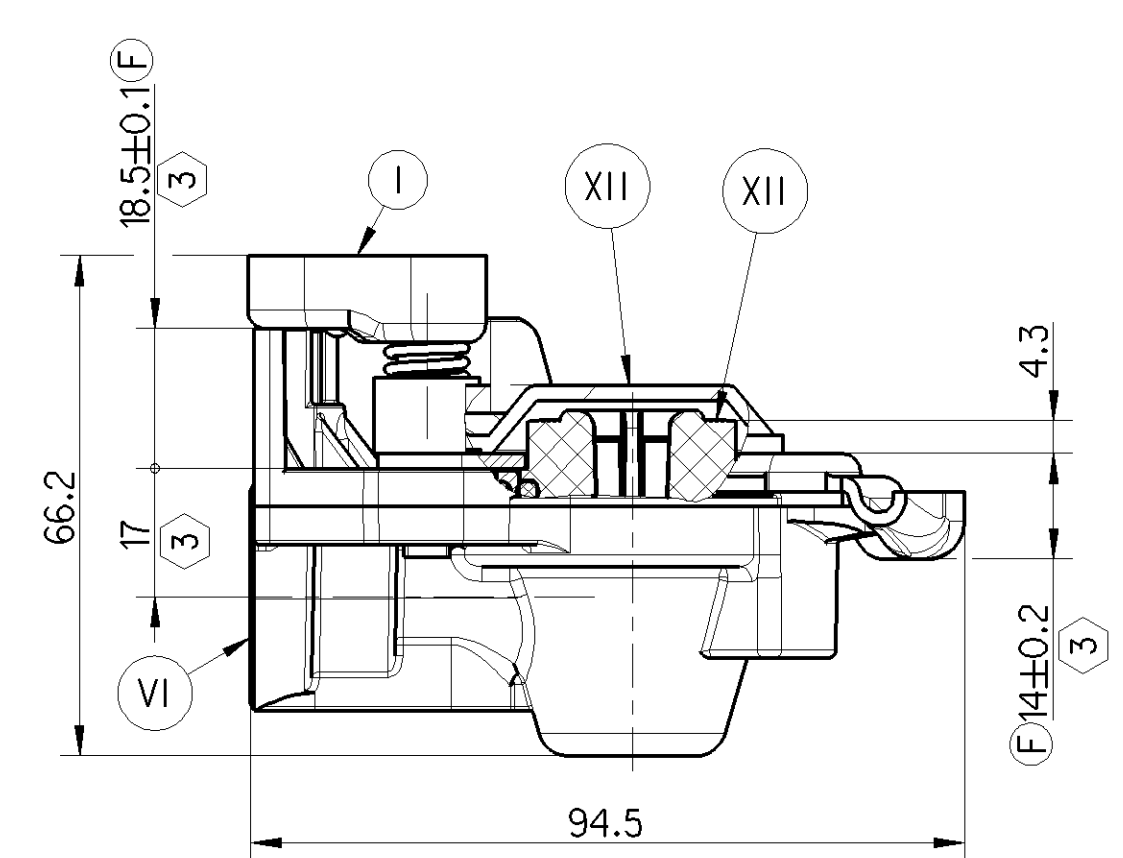
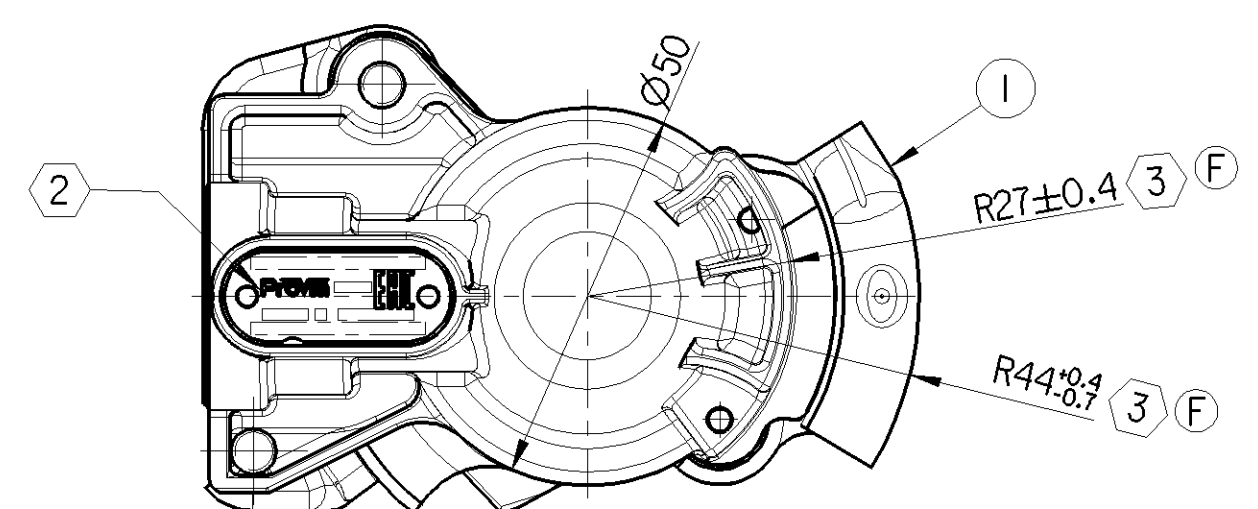

- NOTES:
- (1) SHUTTER COLOUR YELLOW
 - (2) DEVICE PART NUMBER AND BATCH NUMBER SHOWN
 - (3) DIMENSIONS WILL BE ENSURED IN CHILD PARTS ONLY
 - (4) CUSTOMER TO ENSURE TORQUE 31±3 Nm.
 - (F) (5) SHUTTER STOP POSITION

General Specification: JED-334-1, Size ISO 14405 LP		Copyright WABCO®		ProVia		HOSE COUPLING TRACTOR CONTROL											
Further Technical Data:		Date	Signature														
Doc. Code:	Sheet:	To	Drawn	2018-07-12	Aswinkumar	Checked	Suresh Gayakwad	Date of first issue: 2015-04-24									
General Tolerances JED-261		2018-07-13	Saravanan	Expert													
Range of Nominal Dimensions (± mm)		SURESH GAYAKWAD		Material No.		Date of first issue: 2015-04-24											
Class	1)	≤ 50	> 50 ≤ 180	> 180 ≤ 400	> 400	±3°	Mass		Scale		Date of first issue: 2015-04-24						
Fine		0.5	1.0	1.5	2.0		0.266	1:1	PRO 200 222 0		Doc.Code	Language	Sheet				
Medium	X	1.0	2.0	3.0	4.0	Size	CAD System	005		EN		1/1					
Coarse		2.0	3.5	5.0	6.5			A 2		CREO		ECN-No.		Revision		Techn. Resp.	
Tapped Holes acc. JED-152		176833		10		F		5710_AM									
1) Tolerance Class Applied Crossmarked																	

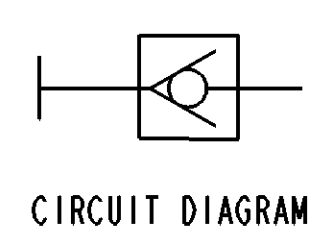

PART CODE	MATERIAL	SURFACE PROTECTION
XVII	STEEL	NO TREATMENT
XVI	CAST IRON	PLATED
XV	STEEL	ZINC-IRON PLATED
XIV	CAST IRON	NO TREATMENT
XIII	ZINC ALLOY	ANODISED
XII	PLASTIC	NO TREATMENT
XI	RUBBER	NO TREATMENT
X	STAINLESS STEEL	NO TREATMENT
IX	BRASS	NO TREATMENT
VIII	ZINC ALLOY	CHROMATED
VII	ALUMINIUM ALLOY	ANODISED
VI	ALUMINIUM ALLOY	CHROMATED
V	CAST IRON	PAINTED
IV	STEEL	POWDER COATED
III	STEEL	PAINTED
II	STEEL	PHOSPHATED
I	STEEL	ZINC PLATED

Non e permesso copiare, o terzi o riprodurre questo documento, ne utilizzare il contenuto o renderlo comunque noto a terzi senza autorizzazione esplicita. Ogni infrazione costituisce un evidente abuso e comportera il risarcimento dei danni subiti. E' fatta riserva di tutti i diritti derivanti da brevetti o modelli.

Copyright of this document and giving it to others and the use or communication of the contents thereof, are forbidden without express authority. Contention of this restriction will constitute an evident abuse and result in a liability to the payment of damages. All rights are reserved in the event of the grant of patent or registration of a utility model or design. This document is the subject of copyright.

Tout communication ou reproduction de ce document, toute exploitation ou communication de son contenu sont interdites, sauf autorisation expresse. Tout manquement a cette regle constitue un abus evident et expose son auteur au versement de dommages et interets. Tous droits de proprieete industrielle reserves, notamment en matiere de brevets et de modesles.

Wiederholte sowie Verbreitung dieser Unterlagen, Verfertigen und Mitteilen ihres Inhalts nicht gestattet, soweit nicht ausdreslich ansonsten, zweckbindend, schriftlich oder durch andere Mittel der Verbreitung oder Gebrauchsmuster-Eintragung vorbehalten. Alle Rechte hier den Fall der Patentierung oder Gebrauchsmuster-Eintragung vorbehalten.

Non e permesso copiare, o terzi o riprodurre questo documento, ne utilizzare il contenuto o renderlo comunque noto a terzi senza autorizzazione esplicita. Ogni infrazione costituisce un evidente abuso e comportera il risarcimento dei danni subiti. E' fatta riserva di tutti i diritti derivanti da brevetti o modelli.