

TailGUARD™ FOR TRAILERS

TailGUARD™ Configurations

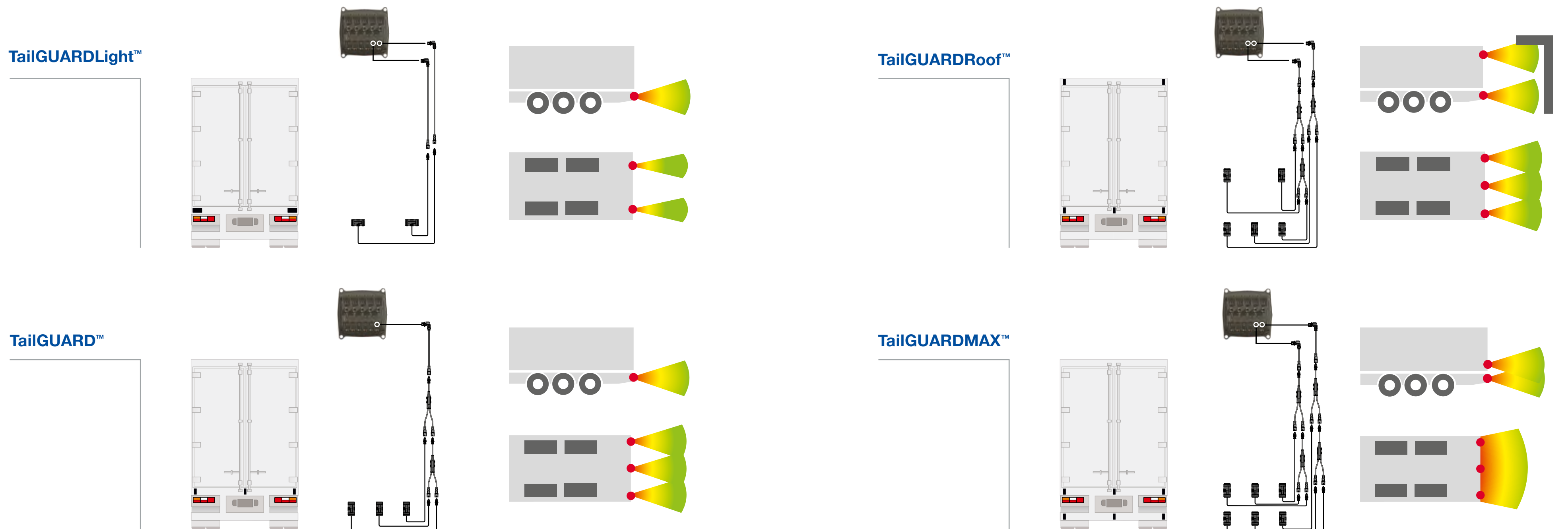

Sensor beam illustrations do not represent exact detection areas

Plug Concept and Cables

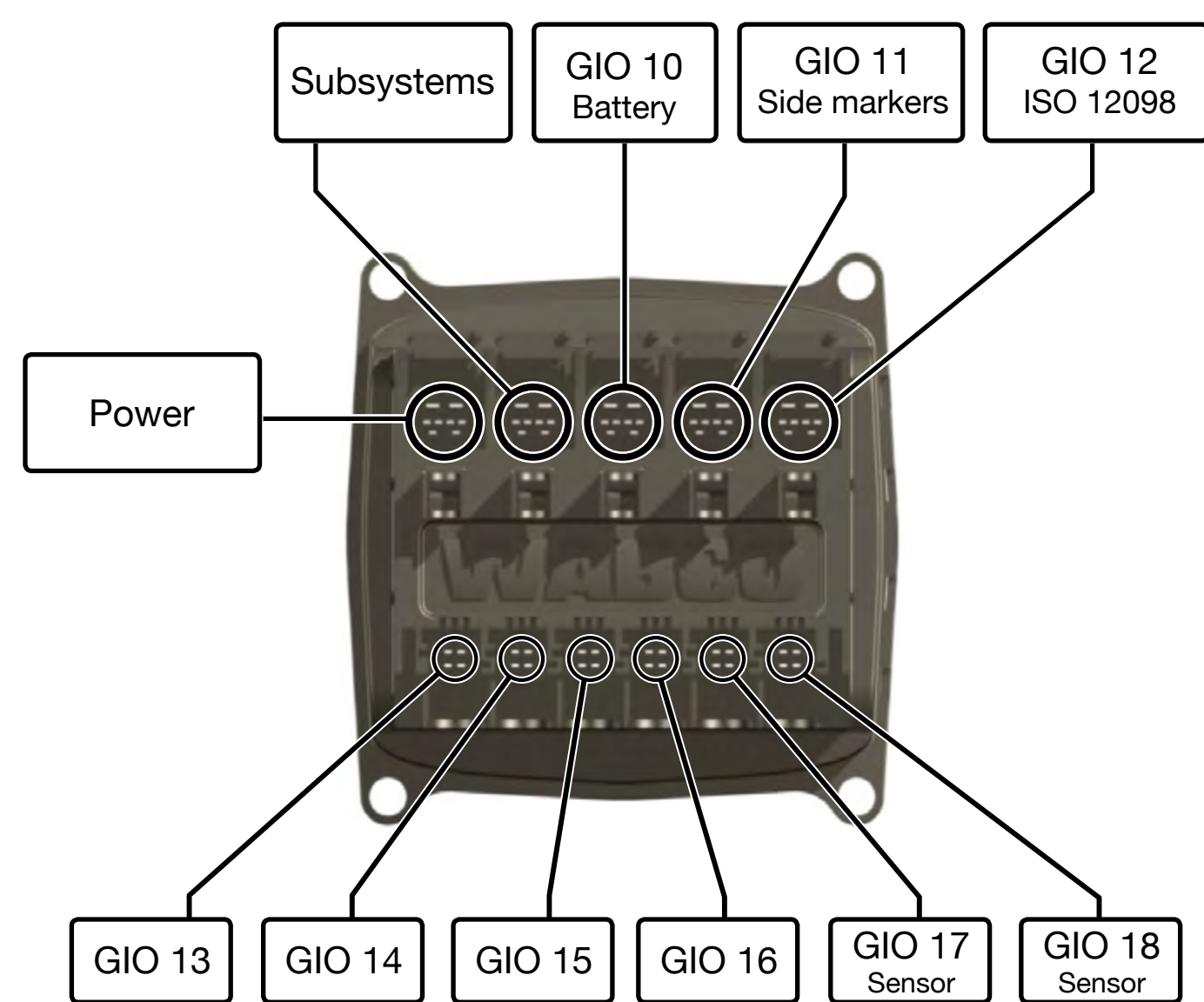

Supply cable	Universal cable (ISO 12098)	SmartBoard cable	SmartBoard and IVTM cable
449 303 ... 0	449 908 ... 0	449 906 ... 0	449 925 ... 0
LIN Ultrasonic sensor cable	TEBS-E battery cable	Telematic cable	SmartBoard and ECAS remote control cable
449 806 ... 0	449 807 ... 0	449 907 ... 0	449 926 ... 0
LIN extension cable	TEBS-E battery supply cable	Remote control cable	
449 720 ... 0 449 747 ... 0 449 746 ... 0	449 808 ... 0	449 602 ... 0	
LIN ,Y' distributor cable	Distributor battery or light cable	Control box cable	
894 600 024 0 0.15/0.15 m	449 803 ... 0	449 603 ... 0	

Trailer Remote Control Wiring

The Trailer Remote Control is installed between terminal 30 and Ground in the fuse box of the truck. If no Power Line Communication signal builds, the distance between the Trailer Remote Control and terminal 30 should be extended with a wire (1.5 – 4.0m/4mm²) to uncouple the Power Line Communication signal.

- Warning lamps**
- Lining wear indicator
 - Immobilizer on/off
 - Tyre Pressure alert
 - Reverse gear selected
 - Obstacle visualisation
 - Key pressed indicator
 - Programmable function buttons

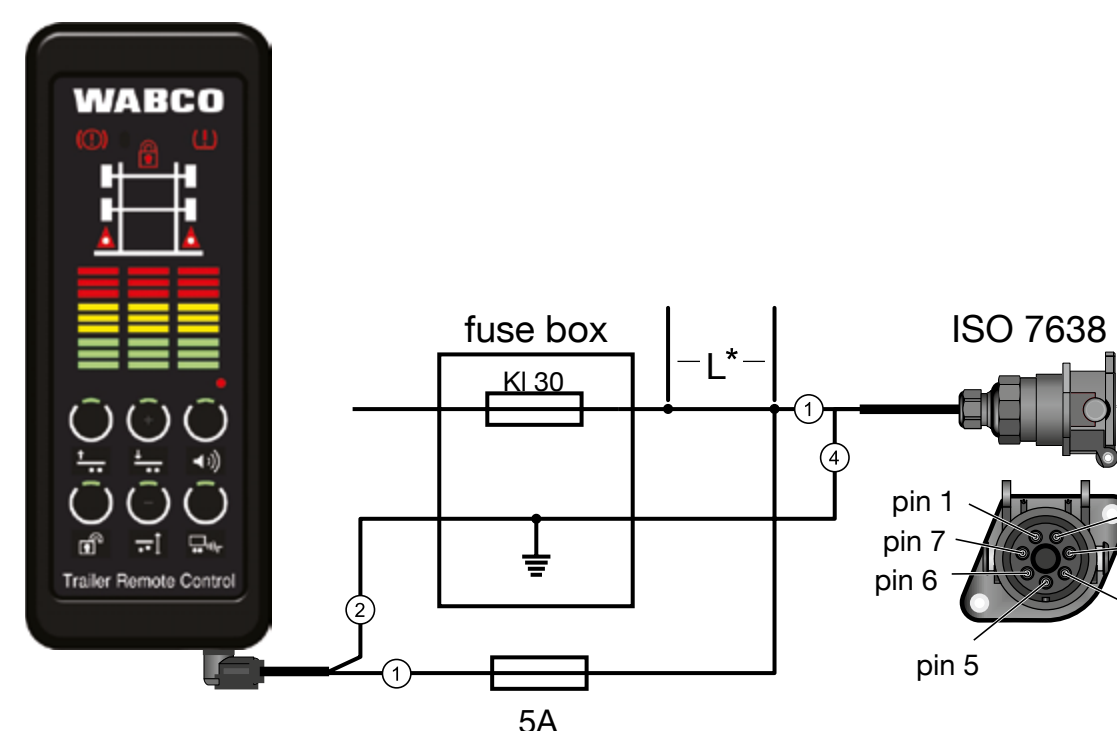

- Traction help/ Forced lowering
- Manoeuvring aid
- Driving level II/I
- Forced lowering
- Finisher brake
- Inclination
- ECAS lift
- ECAS lower
- Unloading level
- Immobilizer on/off
- TailGUARD on/off
- Volume

ISO 12098 Wiring

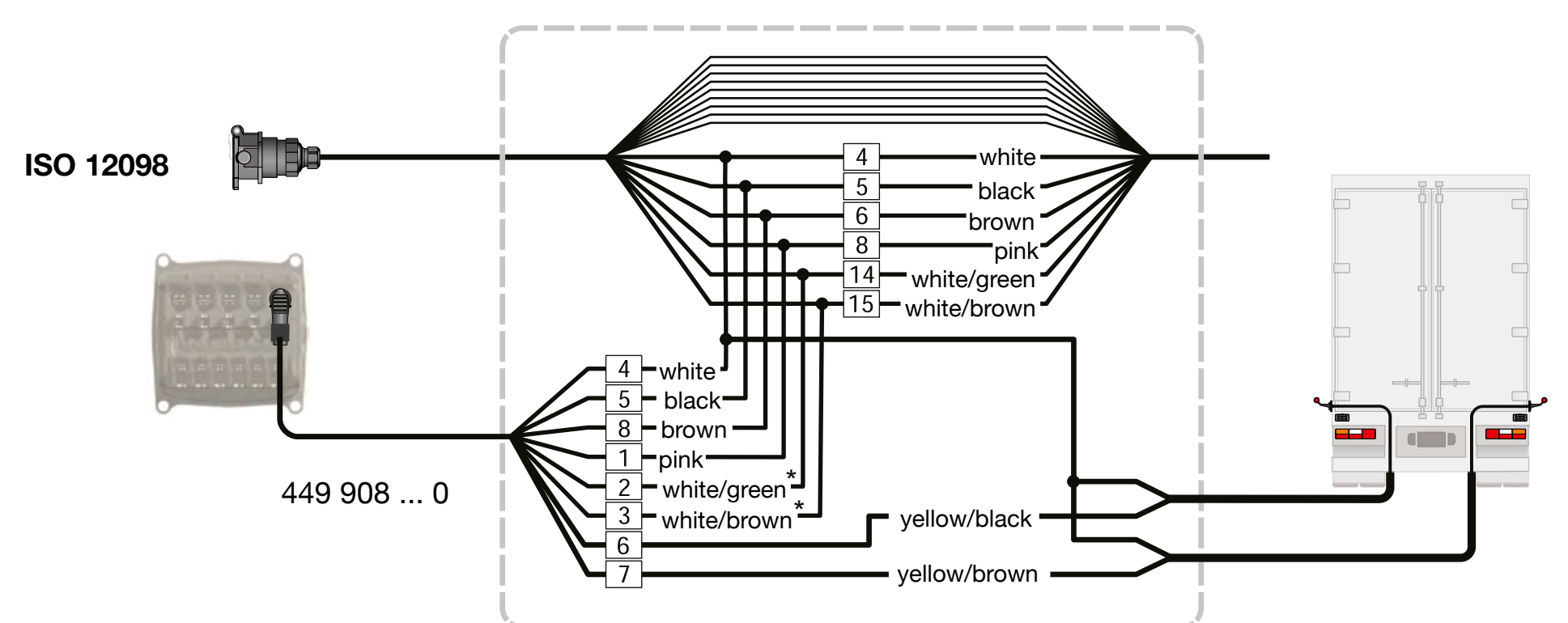

	PIN GIO12	Cable colour ISO 4141	PIN ISO 12098	Terminal
Reversing light	1	pink	8	L
CAN-High (optional)	2	white/green	14	
CAN-Low (optional)	3	white/brown	15	
Common ground	4	white	4	31
Rear light on left	5	black	5	58L
Side marker light off left	6	yellow/black		
Side marker light off right	7	yellow/brown		
Rear light on right	8	brown	6	58R



TailGUARD™ supports the driver and does not take away the responsibility to drive carefully and slowly.
Automatic braking and Trailer Remote Control require a Trailer EBS E Version 2 or higher premium modulator.
TailGUARD™ can be retrofitted on existing trailers, without automatic braking and without Trailer Remote Control.

