

# WABCO

## Technical Bulletin

### Air Dryer Application Guidelines System Saver Series and System Saver Twin

#### How to Obtain Additional Maintenance, Service and Product Information

Refer to the following WABCO publications:

- Maintenance Manual 34, System Saver Series Air Dryers
- Maintenance Manual 35, System Saver Twin Air Dryer
- Maintenance Manual MM-1696, System Saver Series Electronic Air Processing

If you have any questions about the material covered in this publication, or for more information about the WABCO product line, please contact WABCO North America Customer Care at 855-228-3203 or visit our website: [wnacustomer@wabco-auto.com](mailto:wnacustomer@wabco-auto.com).

#### Purpose of this Publication

This Application Guide for WABCO's System Saver Series and System Saver Twin air dryers:

- Addresses air dryer selection and installation criteria for WABCO's System Saver Series and System Saver Twin air dryers,
- Discusses the air supply system,
- Illustrates and describes system components and
- Highlights features and benefits of the System Saver Series and Twin air dryers.

#### Why a Vehicle Needs an Air Dryer

- When air is compressed, the compressor takes in water vapor with the air, compresses the water vapor and puts it into the system as liquid water. Figure 1.
- Liquid water that accumulates in air lines can damage seals and valves, and wash away lubricants.
- In cold weather water can freeze, block air lines and damage air system components.



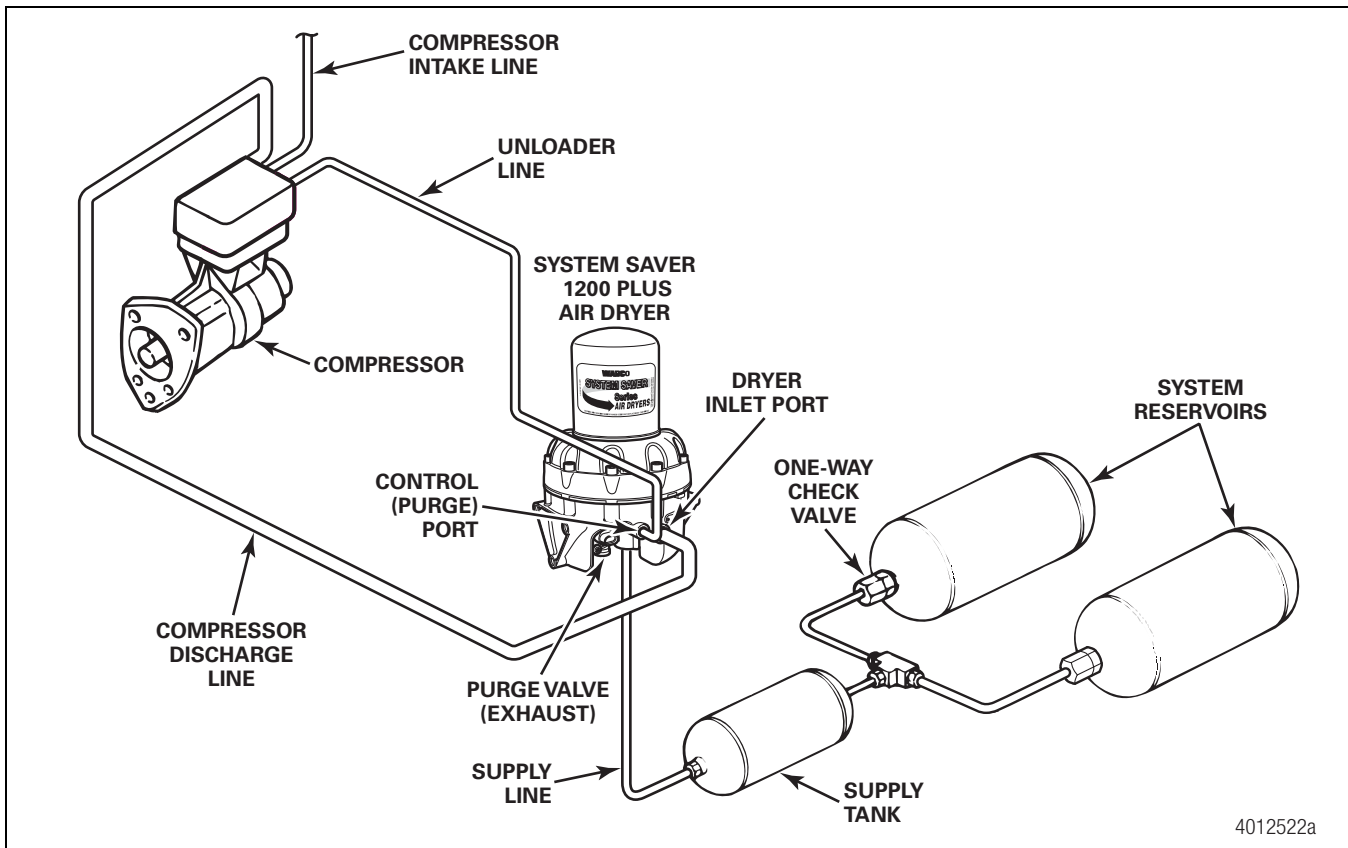

Figure 1

## What a Desiccant-Type Air Dryer Does

- Warm, humid air from the compressor condenses into either liquid water or water vapor **before** entering the air dryer.
- A desiccant-type air dryer protects a vehicle's air brake system by drying moisture-laden air before it passes through the air reservoirs and into the brake system.
- Water collects in the base of the dryer when:
  - Warm air condenses into water before it enters the dryer.
  - Warm air condenses into water inside of the dryer before the water reaches the desiccant cartridge.
- The desiccant material then removes additional water vapor, further drying the air.
- A coalescing cartridge has additional material in the cartridge to trap oil and aerosol particles.
- During the regeneration phase, water is removed from the desiccant bed with a backflow of dried, expanded system air.

## Air Dryer Identification

Identification designations for the System Saver family of air dryers.

Model	Designation
RC Model	A system regeneration model with turbo cut-off valve which uses system air pressure to regenerate the cartridge. A pressure controlled check valve is often used in place of a single check valve if additional air is needed from one of the brake reservoirs.
1800 Model	A system regeneration model same as RC Model, but cartridge has 50 percent more desiccant.
P Model	An external purge model with turbo cut-off valve where a separate reservoir holds air for dryer purging and cartridge regeneration.
U Model	A system regeneration model without a turbo cut-off valve for use on compressor applications where a blocked discharge is not desired.
E Model	A system regeneration model for Holset "QE" compressor requirements.
G Model	A system regeneration model with turbo cut-off valve and with integral governor for air compressor control.
UP Model	An external purge model without a turbo cut-off valve.

Model	Designation
ECAD Model	A system regeneration model with solenoids that are externally controlled to manage dryer purging, cartridge regeneration and compressor control.
Plus Model	A model with integral purge tank and governor on the dryer body. Versions are available with and without turbo cut-off valves.
Plus MCP Model	A model with integral purge tank and governor on the dryer body. Also has system pressure protection elements integrated into the body of the air dryer.
Plus EAP Model	A model with integral purge tank and solenoids that are externally controlled to manage dryer purging, cartridge regeneration, and compressor control.
IWT Model	A model with integral purge tank where the purge tank doubles as the supply/wet tank. The dryer includes a manual drain valve to fulfill FMVSS 121 requirements.
MCP EAP Model	A model with integral purge tank that combines the features of the "Plus MCP" and "Plus EAP" models.
Twin Model	A model with two (desiccant or coalescing) cartridges that is able to handle up to a 100% duty cycle due to a design that provides regeneration by cycling pumped air between the two cartridges. Versions are available with and without turbo cut-off valves.

## Choosing the Right Air Dryer for an Application: Single or Twin Cartridge

### WABCO's Single- and Dual-Cartridge Desiccant Air Dryers

#### System Saver Series Single-Cartridge Air Dryer

The System Saver Series single-cartridge air dryer dries compressed air during the loaded cycle and regenerates (dries) the desiccant bed during the regeneration phase, which occurs when the compressor unloads.

#### System Saver Twin Dual-Cartridge Air Dryer

The System Saver Twin dual-cartridge air dryer incorporates a solenoid valve that alternates incoming airflow between the two cartridges to simultaneously dry air in one cartridge and regenerate the desiccant bed in the other cartridge.

WABCO does not recommend using the System Saver Twin air dryers with single cylinder compressors.

**NOTE:** You cannot construct a dual-cartridge air dryer by plumbing together (in series or parallel) two System Saver Series single-cartridge air dryers. The System Saver Twin air dryer's dual-cartridges work by **simultaneously** drying air in one cartridge and regenerating the desiccant bed in the other cartridge. This simultaneous drying process cannot be achieved by plumbing together two System Saver Series single-cartridge air dryers.

### System Saver Series Single Cartridge

1. The air compressor on-time is two minutes or less (excluding the initial air system build-up time).
2. The normal duty cycle of the air compressor (duty cycle = on-time ÷ total running time) is less than 30% after excluding the air system's initial build-up time.

### System Saver Series EAP

1. The normal duty cycle of the air compressor is less than 45% after excluding the air system initial build-up time.
2. The minimum purge time can be 4 seconds.

### Typical Vocations

- Single or tandem axle on-highway tractors that pull trailers with a tractor/trailer combination of up to a total of six axles.
- Trucks with single or tandem axles that are used for construction, P&D and local hauling.

Selecting the Optimum WABCO Air Dryer	System Saver	System Saver EAP	System Saver Twin
Typical Compressor Loaded Time is 2 Minutes or Less (Excluding Initial Buildup)	√	√	
Typical Compressor Loaded Time is Greater than 2 Minutes			√
Normal Compressor Duty Cycle is Less than 30%	√	√	√
Normal Compressor Duty Cycle is Greater than 30%		√	√
Normal Compressor Duty Cycle is Greater than 45%			√

## System Saver Twin Dual Cartridge

1. The air compressor on-time is greater than two minutes during normal running.
2. The normal duty cycle of the air compressor (duty cycle = on-time ÷ total running time) is greater than 30%.
3. Air system pressure is maintained at normal working levels (greater than 85 psi).

### Typical Vocations

- City buses that stop frequently.
- Garbage trucks in residential areas.

## System Saver Twin or System Saver Series with a Bypass Line for Non-Brake Devices

1. Air compressor on-time for the brake system is less than two minutes, but non-brake devices require pumping times of over two minutes for specific periods of time.
2. Air pressure from the vehicle's air compressor powers or feeds other high-consumption accessories.

### Typical Vocations

- Bulk unloaders that typically use air from large compressors to unload a bulk (usually liquid cargo) tank.
- Vehicles with Central Tire Inflation (CTI) systems.
- Specialized trucks or tractors, when accessories demand a high air consumption (for example, trucks for sewers, septic tanks, etc.).
- Vehicles with air start systems.

## Point Method for Choosing an Air Dryer

The following guidelines and application sheet are provided to help you determine the correct match of air dryer to the specific needs of vocational vehicles. If after using this guideline there is still a concern as to which air dryer to use, please fill out the Vehicle Specification Form and contact WABCO.

Air dryers are generally sized in range similar to compressors. If an application calls for larger compressor output, air dryer upgrades should also be considered. In cases where air quantity is of particular concern (air assisted liquid bulk offload, non-vehicle instruments consuming brake system air), upgrading the air system to an air dryer that can handle more air flow is recommended. In addition, an oil coalescing device can help remove liquid contaminants, increasing the life of the air brakes system and accessories, and depending on system design and the product chosen, the service life of the air dryer may be extended. Oil coalescing devices integrated into the air dryer unit are currently available with all WABCO air dryer products.

It should be noted that vehicle measurement is the best method to determine air consumption accurately in a vehicle. When measurement is not practical, a point system can be used.

## Vehicle Configuration and Vocation Worksheet

The following point system is based on a qualitative understanding of the air consumption of vocations and equipment commonly found on a wide range of vehicles. All elements are estimates. Fill in points accordingly on each of the applicable items below. If not applicable, assign a value of zero. Add up all the points and refer to Air Dryer Recommendations Table.

Item	Vehicle Configuration	Points Schedule	Points Assigned
1	Air-Assisted Bulk Offloading	Add 8 points	
2	Equipped with Central Tire Inflation	Add 8 points	
3	For Every Axle –Tractor and Trailer, but not Lift or Tag	Add 2 points	
4	For Each Lift, Pusher or Tag Axle, Steerable or Not	Add 1 point	
5	Air Suspension	Add 1/2 point per Primary Axle	
6	Stopping Frequency Allowance <i>round to nearest whole number</i> <b>Ex:</b> $(3 \text{ Axles} \times 100 \text{ Stops per hour}) / 36 = 8.333 \approx 8$	$(\# \text{ Axles}) \times (\# \text{ Stops/ hour})$ 36	
7	Hybrid Vehicle Point Adjustment: HLA or Mild Hybrids with Regen Braking should subtract 1/2 Point per Axle	As Required	
8	Equipment not specifically cited that may impact air consumption; Devices that consume air add points, Devices that reduce air consumption subtract points	As Required 1 point per CFM consumed during use	
9	Exhaust After Treatment (if system uses gross system air during regeneration process)	Add 1/2 Point	
<b>Sum of All Points</b>		<b>→→→→</b>	

4012744a

**Figure 2**

**Table A: Air Dryer Recommendations**

System Saver Air Dryer Series	Points			
	≤16	≥16≤24	≥24≤32	≥32≤40
RC, U, E and G	√	—	—	—
ECAD	√	√	—	—
P	√	√	—	—
PLUS (MCP)	√	√	—	—
PLUS EAP	√	√	√	—
1800P	√	√	√	—
UP	√	√	√	—
Twin	√	√	√	√

**Table B: Vehicle Specification Form**

Chassis	Engine	Compressor
Manufacturer	Manufacturer	Manufacturer
Model	Model	Style
Vocation	Emissions Certification Level	Duty Cycle/CFM
Voltage		Turbo-Boosted or Naturally Aspirated?

## General Requirements Guidelines and Installation Criteria

Some installation details may not be covered by the following guidelines. However, WABCO will consider installations that are exceptions to these guidelines when such exceptions are directed in writing to WABCO engineering for approval.

- The air compressor discharge line must be installed in a continual **downhill** run from the compressor to the air dryer. Ensure that no water traps (loops, sags or low points) exist in the line before the dryer.
- Use of fittings that have manufacturer-applied sealant is recommended.
- Whenever possible, mount the air dryer in a location where water, mud, slush, etc., cannot splash or spray directly onto the air dryer.
- There should be no valves or other devices in the dryer to supply tank line that would prohibit or restrict the flow of air back from the supply tank to the air dryer.
- Whenever possible, mount the air dryer at least 12 inches from any heat-producing sources, such as exhaust manifolds or pipes, transmissions, etc.
- A direct line from the air governor must feed the dryer's purge valve where the governor or control devices are not integral to the dryer.
- **For the System Saver Twin only:** In an application such as bulk unloading or Central Tire Inflation (CTI), for example, where the system's working pressure can be lower than 85 psi, use a WABCO Back Pressure Control Valve (or an equivalent valve) to hold air dryer pressure at 85 psi or higher.

**Table C: General Installation Criteria for System Saver Series and System Saver Twin**

Operating Parameters		Requirements
Temperature	Ambient operating range	-40°F to 175°F (-40°C to 80°C)
Electrical power	For heater or heater and solenoid/timer power	12V or 24V available
Thermostat range	On-temp., off-temp.	45°F, 86°F (7°C, 30°C)
Discharge line diameter	From compressor to air dryer	5/8-inch minimum 3/4-1-inch for compressor output greater than 21 CFM
Discharge line length	20 feet maximum. 6 feet minimum to control air temperature entering the air dryer to 149°F (65°C) normal operation, 176°F (80°C) for brief periods.	Determined by the temperature of the air at the inlet port of the dryer. After the vehicle has reached normal operating temperatures, the length of the line must be sufficient to keep temperature below 149°F (65°C).
Outlet line diameter	Air dryer outlet line to supply/wet tank	5/8-inch minimum 3/4-1-inch for compressor output greater than 21 CFM.

Table D: System Saver Series Installation Criteria

Operating Parameters		Requirements
Pressure requirements	Maximum pressure	150 psi
	Minimum governor cut-out pressure	115 psi
	Governor range	15 to 25 psi, for EAP 10 to 30 psi (cut-out — cut-in)
Compressor on-time	Normal running	2 minutes maximum
	Occasional (three times per day maximum)	7 minutes
Compressor unloaded time	Minimum for purge cycle	20 seconds, 40 seconds preferred
Maximum duty cycle	Compressor on-time   total running time	30%, 45% for EAP
Discharge line	Temperature at inlet port determines required length and diameter.	To minimize the likelihood of a discharge line blockage during cold climate operation, it is recommended that for metal discharge lines exceeding 9 feet in length, a minimum of 3 feet of 1/2-inch thick closed-cell polyethylene pipe insulation be used at the connection to the air dryer.

Table E: System Saver Series Twin Installation Criteria

Operating Parameters		Requirements
Rated compressor size	Less than 25 cfm	Twin with 0.8 mm orifice
	Between 25 and 40 cfm	Twin with 1.0 mm orifice
	Greater than 40 cfm	Twin with 1.3 mm orifice (Industrial Applications Only)
Pressure requirements	Maximum pressure	150 psi
	Minimum pressure	85 psi
Flow capacity	Compressor rating	50 cfm maximum
Compressor on time	Normal running	unlimited
Maximum duty cycle		100%
Discharge line	Temperature at inlet port determines required length and diameter	<p><b>21 cfm and under</b>— To minimize the likelihood of a discharge line blockage during cold climate operation, it is recommended that for metal discharge lines exceeding 9 feet in length, a minimum of 3 feet of 1/2-inch thick closed-cell polyethylene pipe insulation be used at the connection to the air dryer.</p> <p><b>Over 21 cfm</b>— 10 feet/20 feet — use copper pipe or stainless steel braided teflon tubing for minimum of first 10 feet.</p>



**CAUTION**

Neither the air dryer, nor the heater in the air dryer, can prevent moisture in compressed air from condensing and freezing in the compressor discharge line between the air compressor and the air dryer inlet. Blockages can occur that can result in damage to components.

- Minimize the length of the compressor discharge line to the extent that air dryer inlet temperature does not exceed the 175°F (80°C) maximum. Note: 149°F (65°C) maximum for best drying performance.
- To help prevent water traps and blockages, follow the vehicle manufacturer's guidelines on discharge line material and how to route the line.
- For technical assistance, call WABCO engineering at 248-435-1500.

**System Saver Series RC, P, U, E, G and ECAD Air Dryer Installation Criteria**

System Saver Series RC, P, U, E, G and ECAD profiles are similar and the mounting is the same.

Port Identification	
1	Inlet/Supply Port
4	Governor/Control Port
21	Outlet/Delivery Port
22	Outlet Port (Not Used)
31	Relief/Safety Valve Port

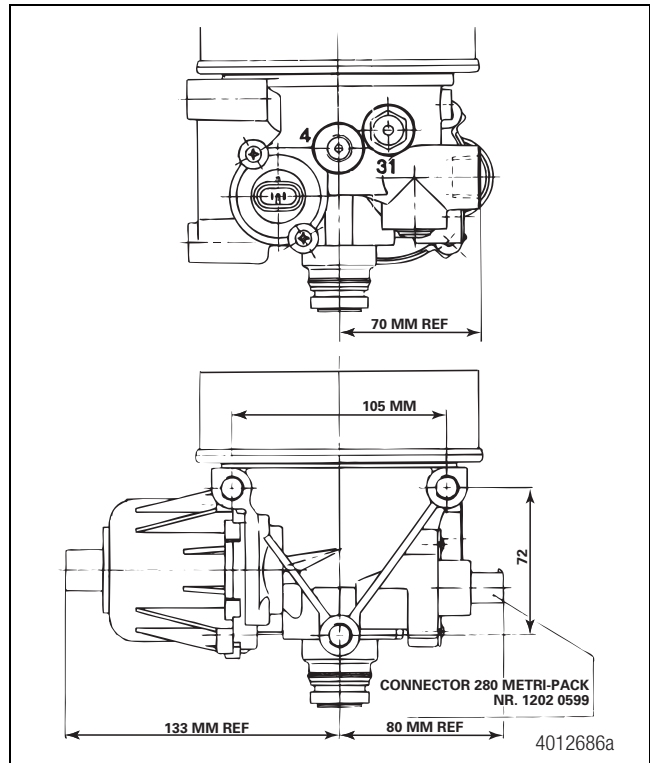

**Figure 3**

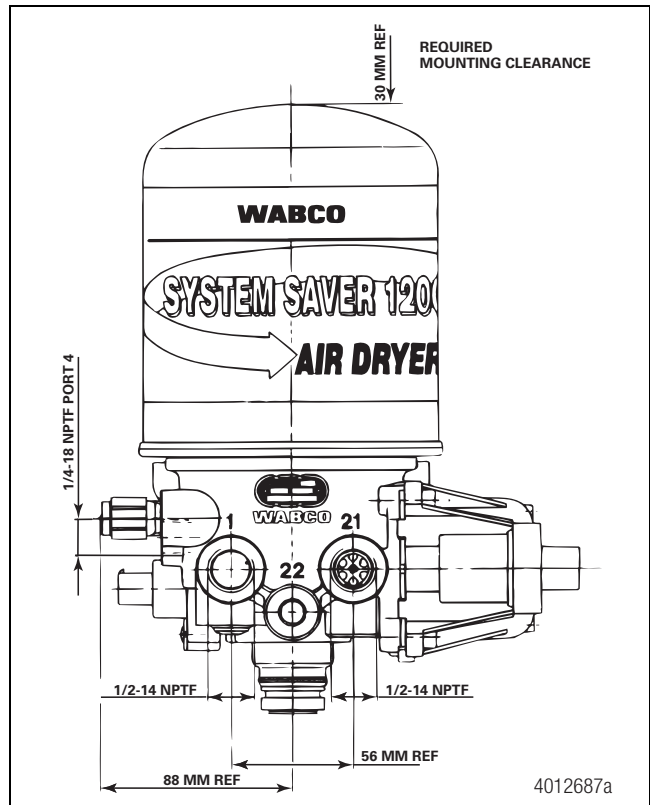

**Figure 4**

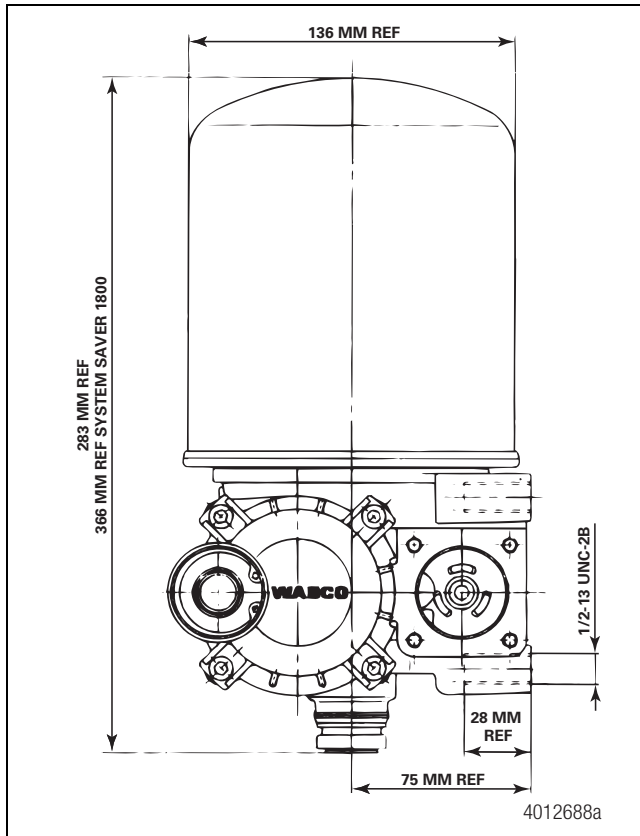

Figure 5

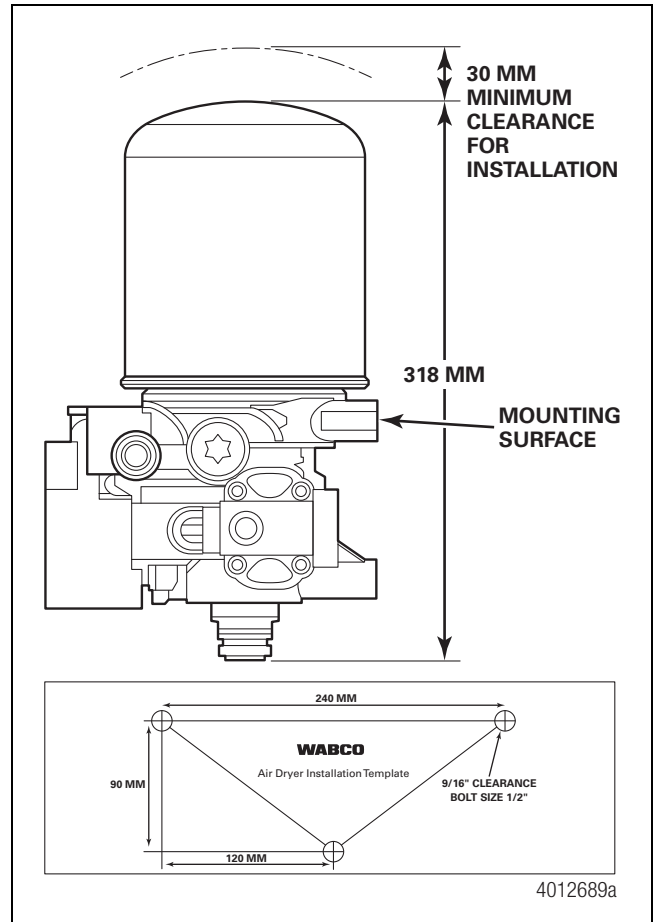

Figure 6

## New System Saver Twin Series Installation Criteria

Turbo Cut-Off Model Shown

**NOTE:** When the compressor receives inlet air from the engine turbocharger, you should install a turbo cut-off air dryer to avoid engine power loss or degraded fuel economy.

Port Identification	
11	Inlet/Supply Port
4/23	Governor/Control Port
21	Outlet/Delivery Port
32	Relief/Safety Valve Port

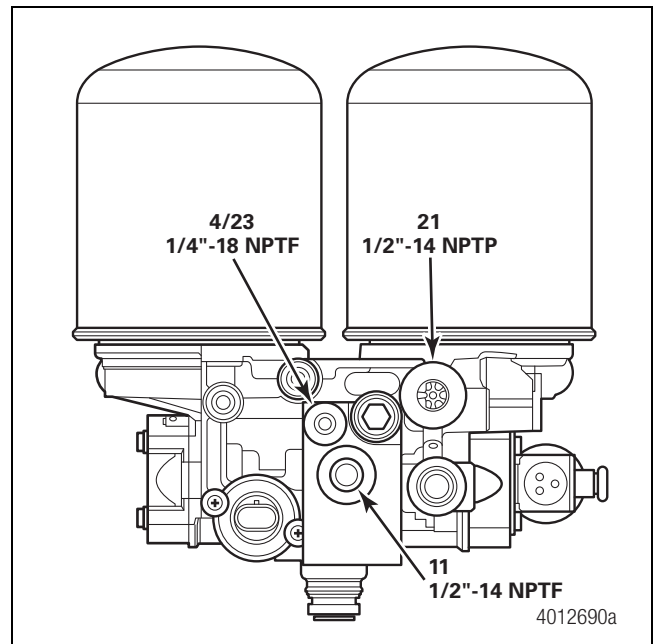

Figure 7

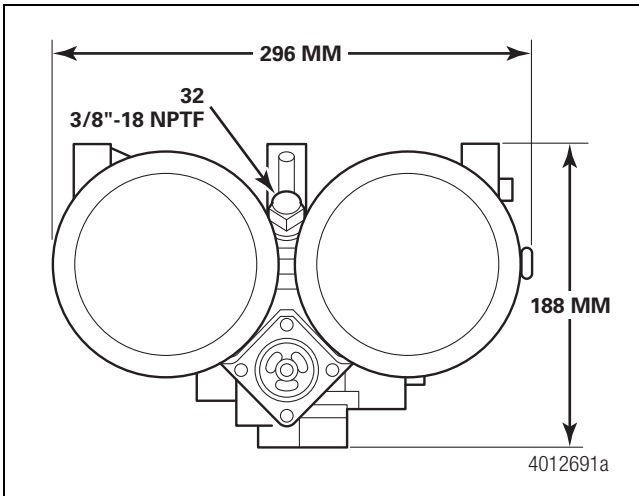

Figure 8

## System Saver Plus and IWT Air Dryer Installation Criteria

System Saver Plus and IWT profiles are similar and the mounting is the same.

Port Identification	
1	Inlet/Supply Port
4	Governor/Control Port
21	Outlet/Delivery Port
31	Relief/Safety Valve Port

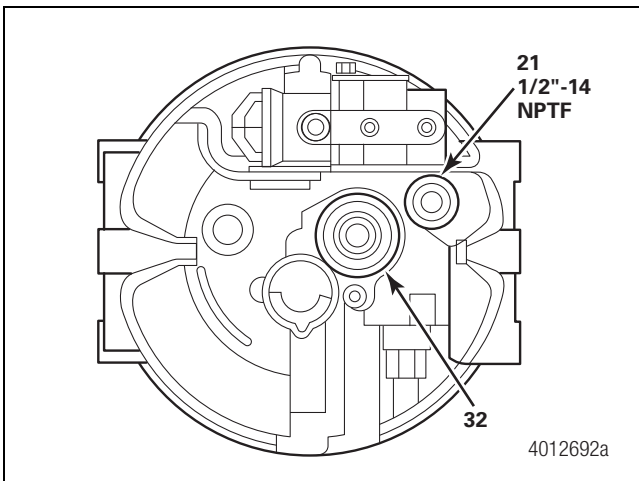

Figure 9

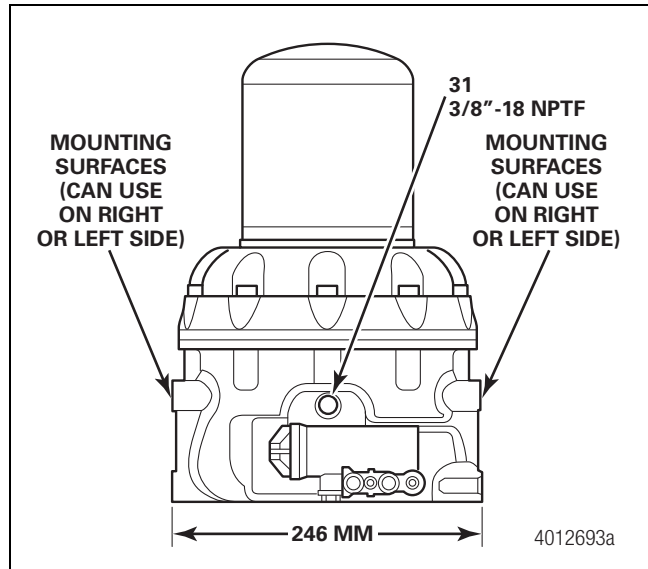

Figure 10

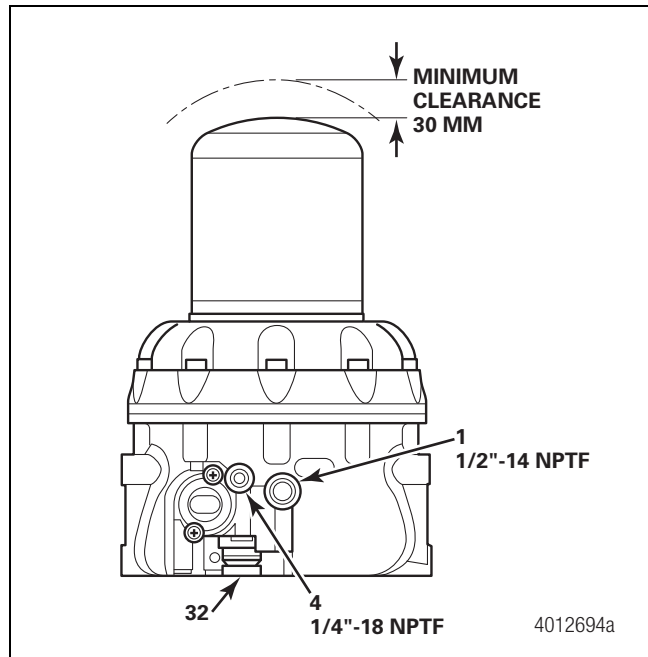

Figure 11

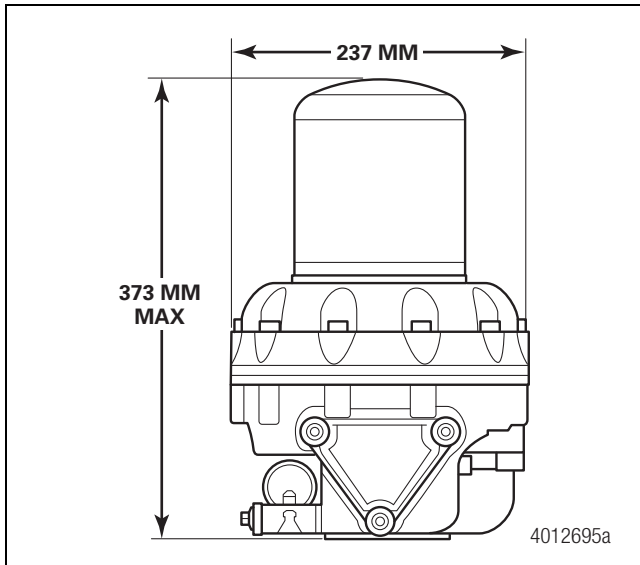

Figure 12

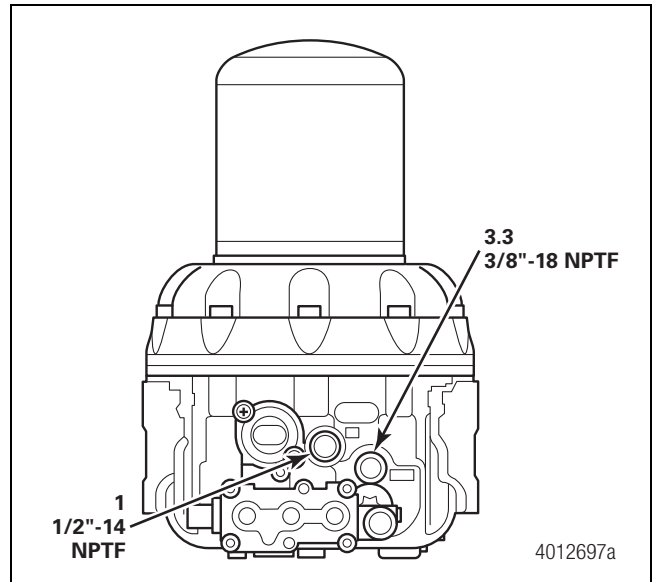

Figure 14

## System Saver Plus with MCP and EAP Air Dryer Installation Criteria

System Saver Plus with MCP and EAP profiles are similar and the mounting is the same.

Port Identification
1 — Inlet/Supply Port
4/2.7 — Governor/Control Port
2.6/3.3 — Relief/Safety Port
2.5/3.2 — Drain Valve Port
2.4 — Auxiliary Device Port
2.1 — Service Brake Port
2.2 — Service Brake Port
2.3 — Trailer Braking System Port or Auxiliary Port

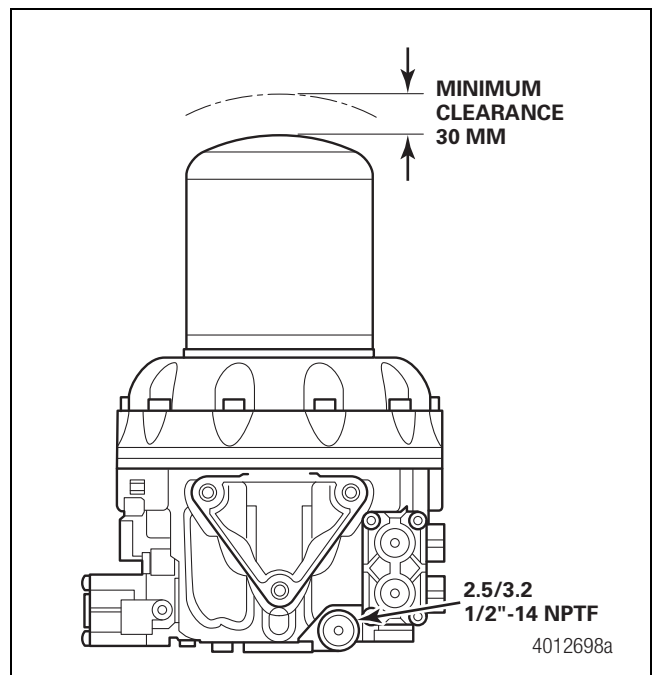

Figure 15

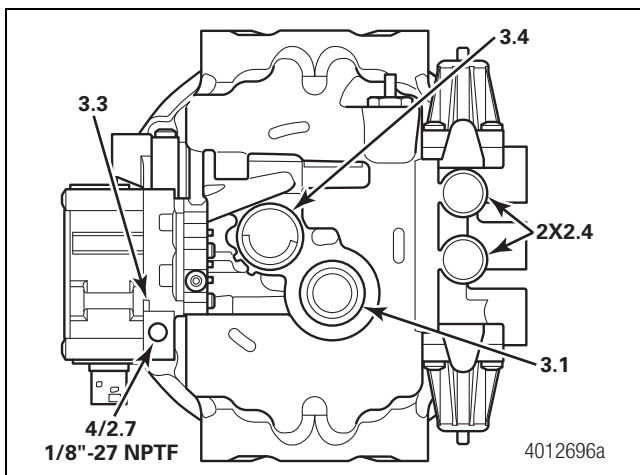

Figure 13

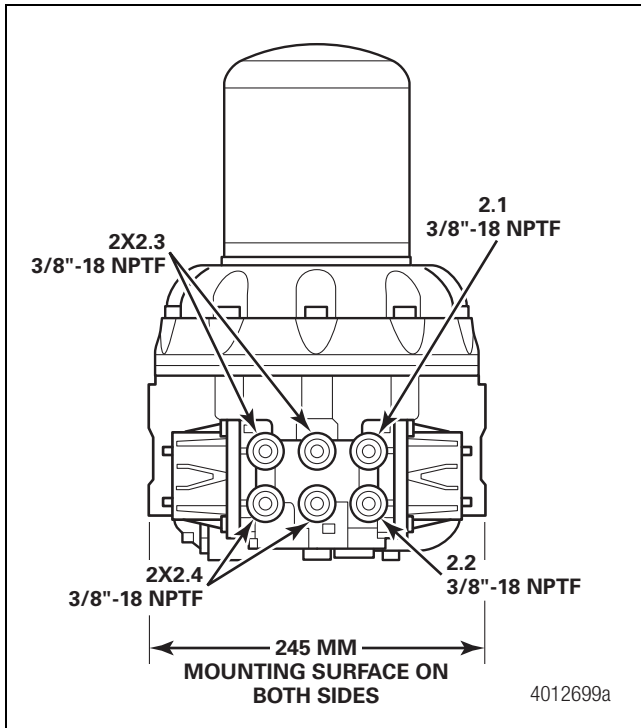

Figure 16

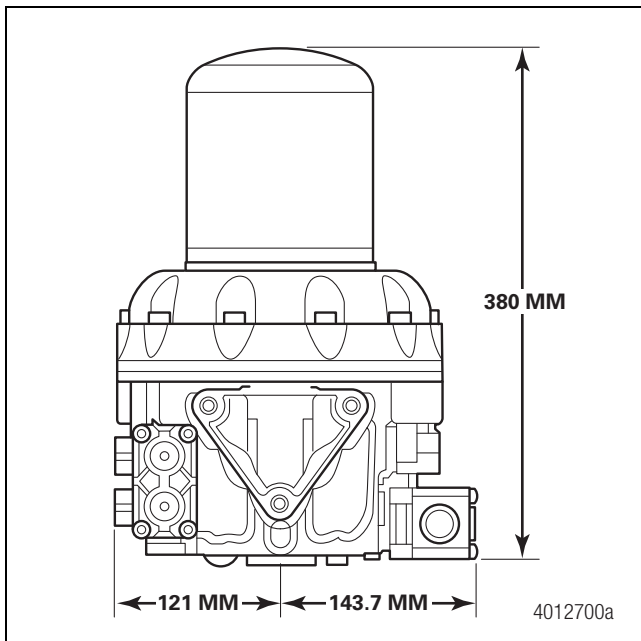

Figure 17

## Air System Components

### Types of Air Compressors

#### Air Induction

The air compressor pumps air to, and builds up pressure in, an air system.

- Naturally aspirated.
- Turbocharged (uses air pressure from the pressure side of the engine turbocharger).

#### Oil in the Air Stream

Compressors used in heavy-duty truck applications discharge some compressor oil into the compressed-air system.

- An air dryer and an air system will tolerate only a minimal amount of compressor oil in the air stream.
- Oil in the air stream affects system components, reduces desiccant efficiency and eventually disables the moisture removal function of the air dryer.
- The use of coalescing cartridges will help minimize the oil damage to the air system.
- Ensure that the compressor operates properly and only discharges minimal oil into the system.

#### Air Governor

The air governor senses pressure level in the system's first tank (typically the supply tank, also known as the "wet" tank) and activates/loads or deactivates/unloads the compressor to control system air pressure.

In some air systems, the governor actuates other components, such as automatic drain valves, greasing systems, etc.

However, to ensure correct air dryer operation, the governor should only control the compressor, air dryer and auxiliary devices directly related to the compressor and the air dryer.

#### Electronic Control Air System

The electronic control air system uses an on-board computer to read pressure levels in vehicle air tanks. The computer controls compressor cycling (loading and unloading). Also, it controls purge and regeneration of the air dryer. Some of the components of the system are pressure sensors, solenoids and a wiring harness.

#### Activates/Loads the Compressor

- When system air pressure lowers to approximately 100-105 psi (cut-in pressure).

#### Deactivates/Unloads the Compressor

- When pressure builds up to approximately 120-140 psi (cut-out pressure), the governor opens an internal valve and applies air pressure from the supply (wet) tank to the compressor's unloader port.

#### Mounting Configurations

1. Bolted to the air compressor head. (Not Recommended)

2. Remote-mounted, connected by an air line to the compressor head. A remote-mounted governor should be lower than the compressor to allow any moisture in the line to move to the governor. Also, WABCO recommends that the governor be positioned higher than the air dryer and the wet/supply tank.
3. Integral to air dryer.

## Air Governor Signal Line

The air governor signal line activates the purge and regeneration cycles of the air dryer, as well as the compressor unload cycle.

### NOTES:

- Do not use the air governor line to activate other devices, such as automatic drain valves, after-cooler-type dryers, etc.
- Install the line directly from the air governor to the air dryer.
- Connect the air governor unload port to the air dryer control port (1/4-inch NPTF, port marked "4") with 1/4-inch or 3/8-inch nylon tubing.

## Compressor Discharge Line

Air from the compressor is hot and contains water, water vapor and contaminants. The compressor discharge line cools the air and delivers it to the air dryer. Water, water vapor and contaminants are removed from the air when it passes through the dryer to be dried and cleaned.

### Installation

1. The compressor discharge line must be installed in a continuous **downhill** run from the compressor to the air dryer.
2. A valve or other component installed in the compressor discharge line can restrict airflow to the dryer and form areas where water can pool and freeze.
3. Avoid sharp bends and 90° fittings, especially at the dryer inlet.
4. Ensure that no loops, bends or sags exist in the line.

### Potential Problem: A Loop, Sag or Bend in the Line

- A loop, sag or bend in the line is a potential water trap, where water can pool, especially when a vehicle is stationary over a period of time with the engine **OFF**.
- In cold weather, water that accumulates in a sag or bend can freeze, block the compressor discharge line and prevent air delivery to the dryer and system.

## When the air dryer is at the same level or higher than the compressor and a downhill line is not possible:

- Route the compressor discharge line **up** immediately out of the compressor as high as necessary to allow the remainder to continue **down** to the dryer.

## Air Dryer to Supply Tank Line

### Installation

Install the line directly from the air dryer to the supply (wet) tank. A check valve in the dryer's outlet ensures that system does not lose air pressure when the engine is stopped.

- Whenever possible, do not install devices in this line that would prohibit or restrict the flow of air back from the supply tank to the air dryer.
- Example: An alcohol evaporator
- Install a bypass line around the alcohol evaporator, so that air can flow freely from the supply tank to the dryer. Figure 18.

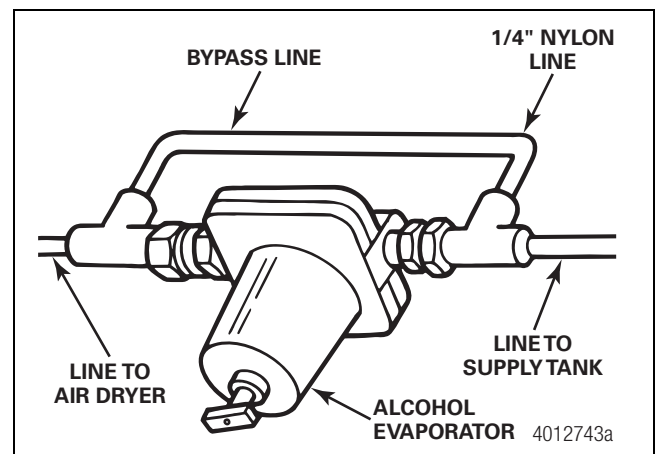

Figure 18

## Air System Reservoir Tanks

### Supply (Wet) Tank, Primary Reservoir(s) and Secondary Reservoir(s)

- Supply/wet tank supplies pressure line to the governor.
- Supply regeneration air to the System Saver Regeneration air dryer models. Regeneration air also comes from other tanks with Pressure-Controlled Check Valve (PCCV) in place.

## Pressure-Controlled Check Valve (PCCV) Placement

The PCCV is typically installed on one of the system tanks in place of the inlet check valve only with System Saver regeneration air dryers. The valve maintains a minimum air pressure in the reservoir tanks and also allows the air dryer to use 10 psi of air volume from the supply (wet) tank and select system tank(s) during the regeneration cycle.

### Air Dryer Operating Parameters

The air dryer cools, filters and dries compressed air to prevent problems with moisture in an air system.

#### A. Check Air Dryer Inlet Temperature

Hot air has the capacity to hold more water than cooler air, so there is less condensation or fall-out before the air reaches the desiccant.

To ensure that the air dryer operates properly, the peak inlet temperature must be **below** 175°F (80°C). Ideal inlet temperature is below 149°F (65°C).

##### If air temperature is ABOVE 175°F (80°C):

- Hot air can melt or prematurely age the air dryer's internal components.

##### If air temperature is BELOW FREEZING (32°F/0°C):

- Water in the air line can freeze and obstruct the dryer before the inlet.

#### B. Protect the Air Dryer from Direct Wheel Splash

Whenever possible, mount the air dryer in a location where water, mud, slush, etc., cannot splash or spray directly onto the air dryer.

Otherwise, protect the dryer with a mud flap or protective shield.

- In cold temperatures, the bottom of an air dryer exposed to wheel splash can freeze and the purge valve will stop functioning.
- Example: Protect the air dryer installed **behind** a front wheel.

#### C. Protect the Air Dryer from Heat-Producing Sources

Whenever possible, mount the air dryer at least 12 inches from any heat-producing sources, such as exhaust manifolds or pipes, transmissions, etc.

- Otherwise, protect the air dryer with an insulator or heat shield.

#### D. Too Much Oil in the System Contaminates the Desiccant

- In heavy-duty truck applications, air from the compressor contains contaminants, such as oil, carbon particles, water and water vapor before it passes through the desiccant cartridge.

- To filter and dry air from the compressor, desiccant-type air dryers use desiccant beads that accumulate water molecules and other contaminants on the surface of the desiccant bed.
- When an air compressor discharges too much oil into the compressed-air system, the oil coats the desiccant beads, preventing adsorption and the removal of water from the system.

#### Prevent Oil Contamination

- An air dryer and an air system will tolerate only a minimal amount of compressor oil in the air stream.
- Oil in the air stream affects system components, reduces desiccant efficiency and eventually disables the air dryer's ability to remove moisture.
- That's why adding a desiccant-type air dryer to a system with a compressor that discharges too much oil will not compensate for a compressor that is not operating correctly.

#### E. Overloading the Dryer

A single-cartridge dryer has a finite drying capacity and should not be run longer than recommended.

#### F. Correct Air Regeneration Volume

Adequate regeneration volume removes moisture from the desiccant cartridge and prepares the dryer for the next compressor load cycle.

- WABCO recommends that vehicles using high air consumption, non-brake related auxiliary devices, such as CTI, bulk unloading, air start, should use a System Saver Twin air dryer.
- If a System Saver Series is used, bypass the air dryer to supply the auxiliary devices.

## Regeneration Methods and Selection Factors

### Desiccant Regeneration Methods

Today's single-chamber air dryers regenerate the desiccant by using either the **On-Board Volume** (also known as the **Integral Purge Volume**) method, the **Purge Tank** method or the **System Air Regeneration** method.

#### 1. On-Board Purge Volume Method (also known as Integral Purge Volume Method)

- The air dryer stores regeneration air within the air dryer instead of in a separate air reservoir.
- Dryer-mounted operating components constitute a heavy, bulky unit.
- This method can only accommodate an air system up to a specific size.

- Single-purpose; uses on-board air only to regenerate desiccant.

## 2. Purge Tank Method

- The air dryer uses a separate reservoir to hold regeneration air.
- The separate air reservoir needs mounting space.
- This method can only accommodate an air system up to a specific size.

## 3. System Air Regeneration

- The System Saver Series, WABCO's single-chamber air dryer, regenerates the desiccant by using the system air regeneration method.
- The regeneration valve controls the flow of air to regenerate the desiccant.
- The air system requires modification to allow the correct amount of air to flow back to the dryer.
- A "proportional purge" method. A dryer uses less air in a small air system; more air in a large air system.

## Air Dryer Selection Factors

### Flow Capacity

#### Cubic feet per minute (cfm)

**Capacity** determines a dryer's rating, as defined by two parameters: the **flow** capacity and the **drying** capacity.

- **Flow** capacity and **drying** capacity determine an air dryer's rating.
- A restriction or pressure drop through a dryer determines a dryer's flow capacity.
- **When a restriction or pressure drop occurs through a dryer:** The compressor must pump to 120 psi (cut-out pressure) plus the amount of the pressure drop. For example, if the restriction or pressure drop is 4 psi, the compressor must pump to 124 psi to reach cut-out.

### Purge Air Volume

**Purge air volume** is the amount of air an air dryer requires to correctly regenerate the desiccant. The purge volume required is proportional to the air that flows through the dryer during a drying cycle.

**For System Saver regeneration air dryers only.** Installing one or more pressure-controlled check valves (PCCVs) in an air system can adjust purge volume for WABCO air dryers.

1. Install a PCCV either on the primary or secondary reservoir tank.
2. Install a PCCV on both the primary and secondary reservoir tanks.

### Governor Range

The **governor range** is the difference between cut-in pressure and cut-out pressure. The amount of air that a compressor pumps through a dryer is proportional to the governor range.

- The wider the governor range, the more air a compressor pumps through a dryer during any given cycle.
- The amount of purge air volume a system requires is proportionate to the governor range.

### Air Compressor Duty Cycle

The air compressor duty cycle determines which air dryer to spec.

#### System Saver Series

##### Single-Cartridge Air Dryer

- Runs a 30% duty cycle or a maximum compressor on-time of two minutes.

##### System Saver Twin

##### Dual-Cartridge Air Dryer

- High duty-cycle applications (over 30%)
- Continuous operation; one cartridge dries while the other cartridge regenerates.
- Does not rely on a compressor unload signal to purge, which is an advantage to vocations such as:
  - Bulk hauler operations, when the compressor may not unload for long periods of time; and
  - Garbage packer and city bus operations, where the compressor runs almost continuously.

## WABCO

WABCO North America  
1220 Pacific Drive  
Auburn Hills, MI 48326 USA  
855-228-3203  
wabco-na.com

Information contained in this publication was in effect at the time the publication was approved for printing and is subject to change without notice or liability. WABCO reserves the right to revise the information presented or to discontinue the production of parts described at any time.

Copyright 2018  
WABCO, Inc.  
All Rights Reserved

Printed in USA

TP-9672  
Revised 09-18  
(16579)